

Telematics

Chapter 6: Network Layer

Univ.-Prof. Dr.-Ing. Jochen H. Schiller
 Computer Systems and Telematics (CST)
 Institute of Computer Science
 Freie Universität Berlin
<http://cst.mi.fu-berlin.de>

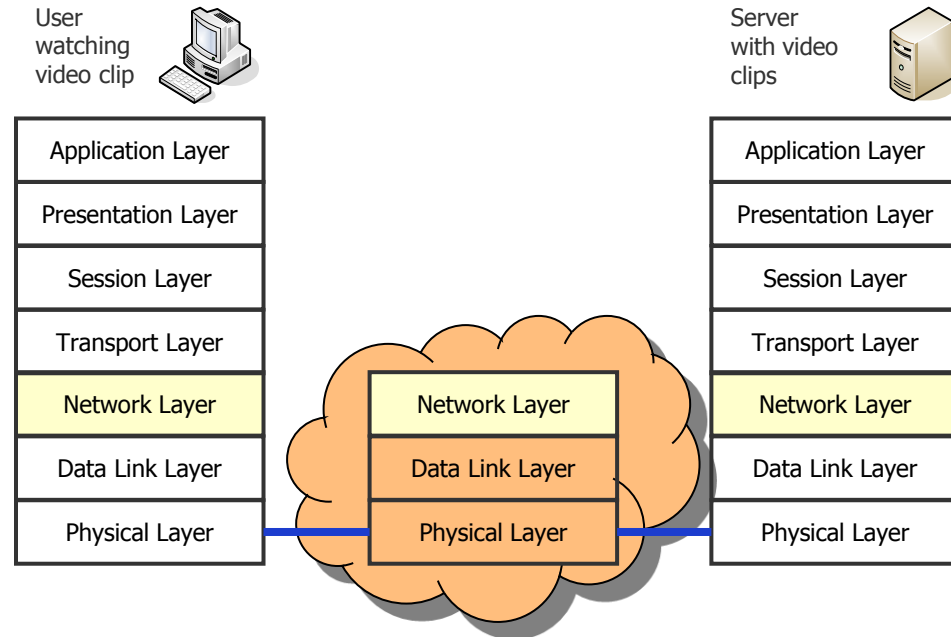

Contents

- Design Issues
- The Internet
- Internet Protocol (IP)
- Internet Protocol Version 6 (IPv6)
- Network Address Translation (NAT)
- Auxiliary Protocols
 - Address Resolution Protocols (ARP)
 - Reverse ARP (RARP)
 - Dynamic Host Configuration Protocol (DHCP)
 - Internet Control Message Protocol (ICMP)
- Routing
 - Shortest Path Routing
 - Distance Vector Routing
 - Routing Information Protocol (RIP)
 - Link State Routing
 - Hierarchical Routing
 - Open Shortest Path First (OSPF) *18-15*
 - Border Gateway Protocol (BGP)
- Internet Group Management Protocol (IGMP)

Design Issues

Connection principles

Layer 3

- Layer 1/2 are responsible only for the transmission of data between adjacent computers.
- Layer 3: Network Layer
 - Boundary between **network carrier** and **customer**
 - Control of global traffic
 - Coupling of sub-networks
 - Global addressing
 - Routing of data packets
 - Initiation, management and termination of connections through the whole network
 - Global flow control

OSI Reference Model

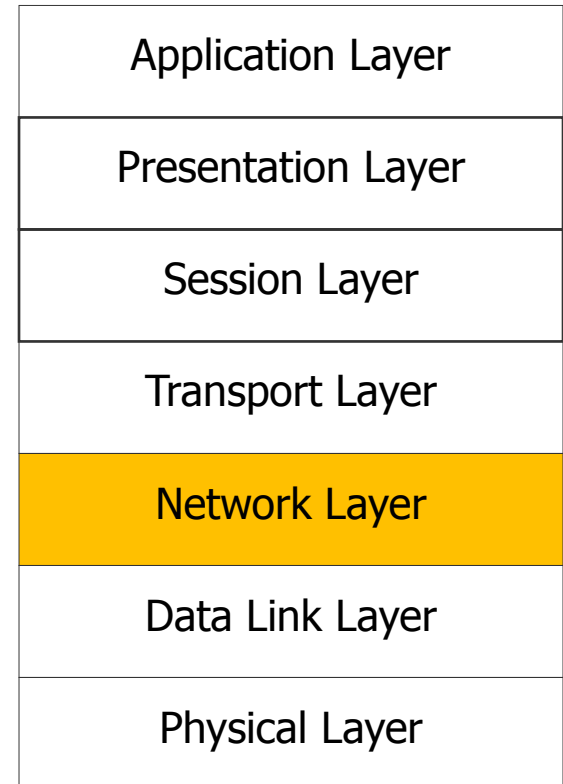

Layers in the Network

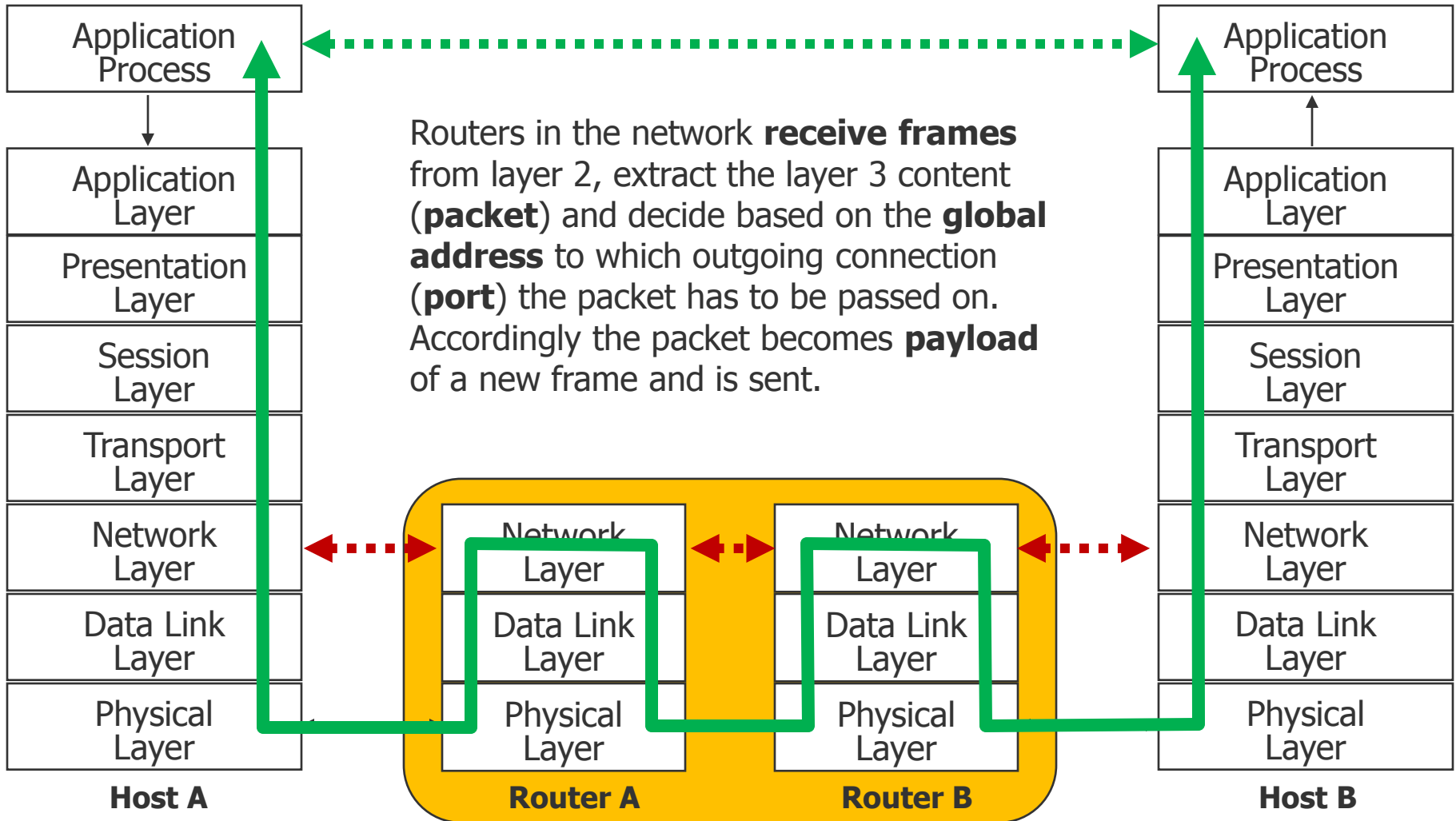

Layers in the Network

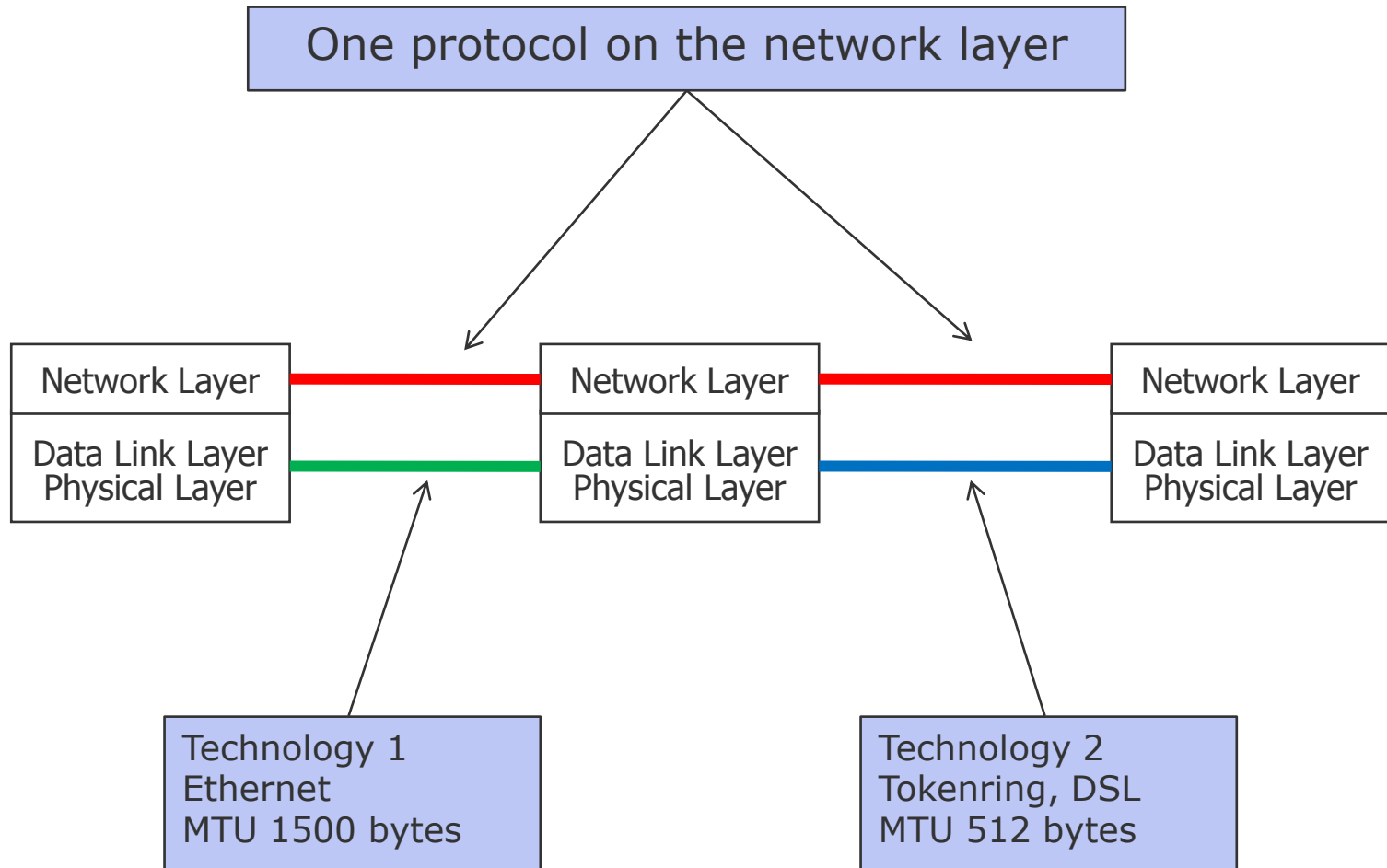

Two Fundamental Philosophies

- Connectionless communication (e.g. Internet)
 - Data are transferred as packets of variable length
 - Source and destination address are being indicated
 - Sending is made spontaneously without reservations
 - Very easy to implement
 - But: **packets can take different ways** to the receiver
 - Wrong order of packets at the receiver, differences in transmission delay, unreliability
- Connection-oriented communication (e.g. telephony)
 - Connection establishment:
 - Selection of the communication partner resp. of the terminal
 - Examination of the communication readiness
 - Establishment of a connection
 - Data transmission: Information exchange between the partners
 - Connection termination: Release of the terminals and channels
 - Advantages: no change of sequence, reservation of capacity, flow control

Connectionless Communication

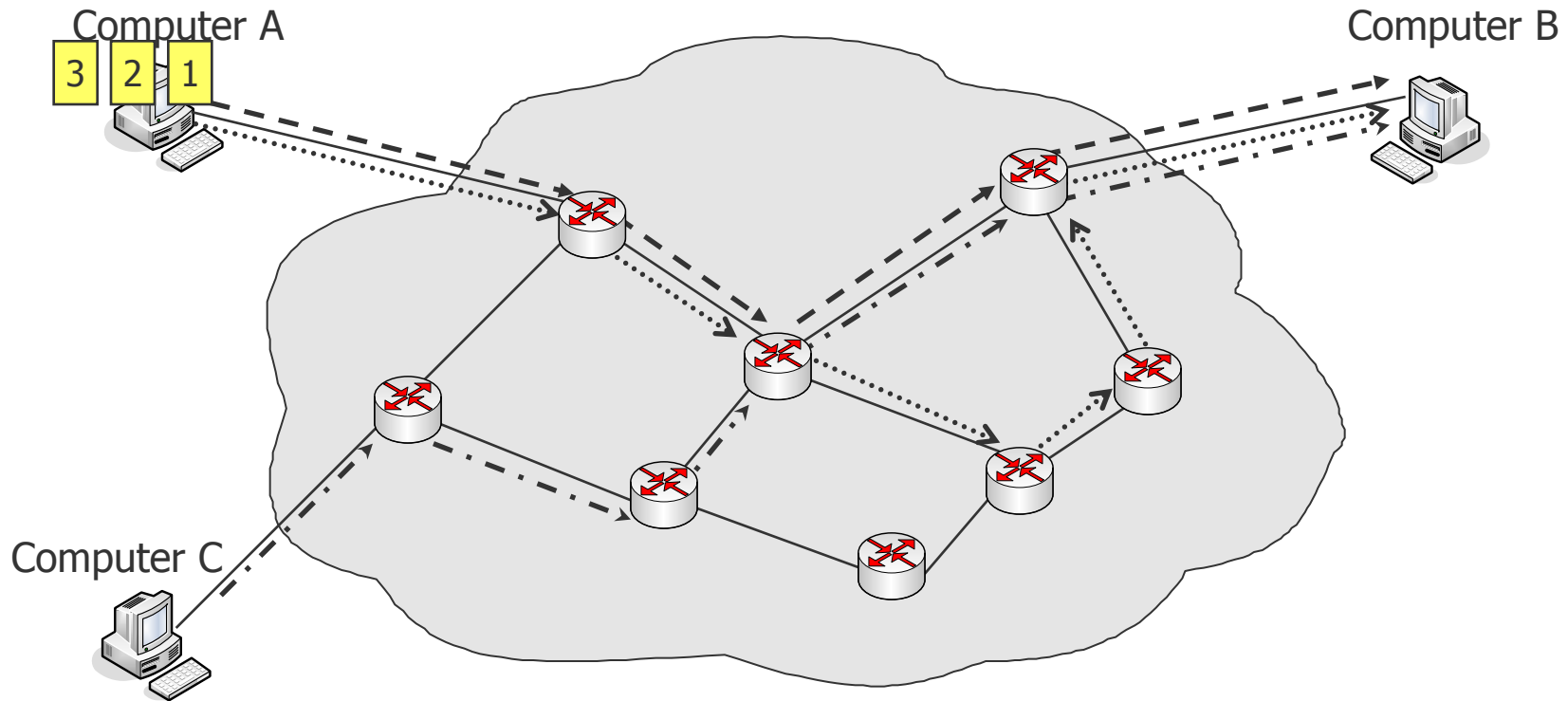

Packet Switching

- Message is divided into **packets**
- Access is always possible, small susceptibility to faults
- Alternative paths for the packets
- Additional effort in the nodes: **Store-and-Forward** network

Connection-Oriented Communication

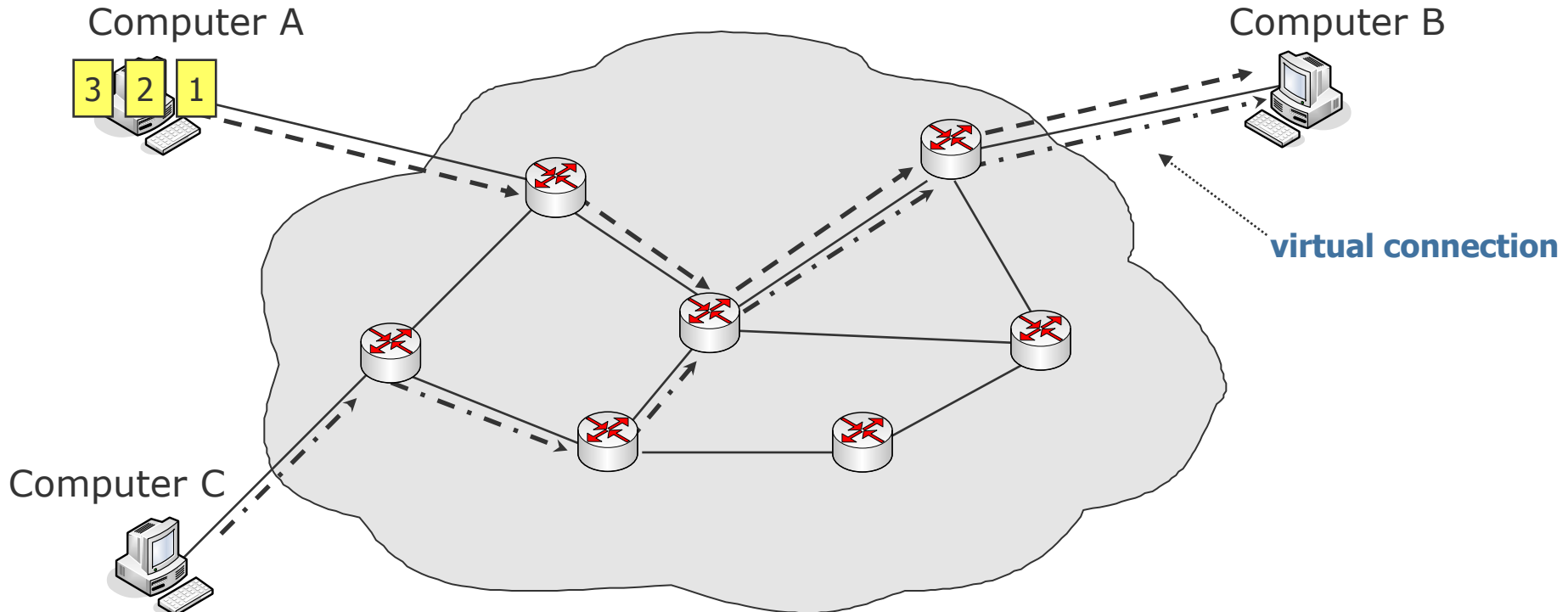

Circuit Switching

- Simple communication method
- Defined routes between the participants
- Switching nodes connect the lines
- Exclusive use of the line (telephone) or **virtual connection**:
 - Establishment of a connection over a (possibly even packet switching) network



Design Issues

Routing principles

Routing

- Most important functionality on Layer 3 is **addressing** and **routing**.
- Each computer has to be assigned a worldwide unique address
- Every router manages a table (**Routing Table**) which indicates, which outgoing connection has to be selected for a certain destination.

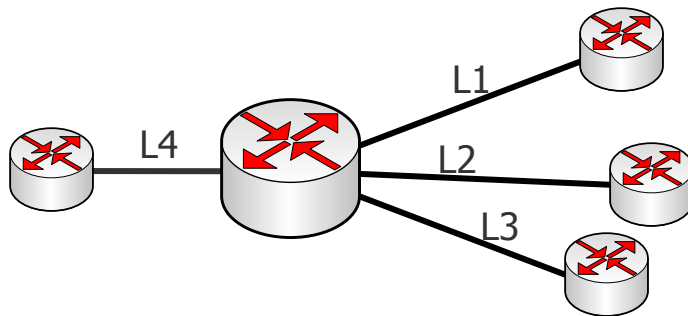

To destination	By connection
A	L2
B	L1
C	L3
D	L2

- The routing tables can be determined **statically**; however it is better to adapt them **dynamically** to the current network status.
- With **connectionless** communication, the **routing** must be done for **each packet** separately. The routing decision can vary from packet to packet.
- With **virtual connections**, **routing** is done **only once** (connection establishment, see ATM), but the routing tables are more extensive

Routing

- Task: determine **most favorable** route from the sender to the receiver
 - Short response times
 - High throughput
 - Avoidance of local overload situations
 - Security requirements
 - Shortest path
- Routing tables in the nodes can be
 - One-dimensional (connectionless): decision depends only on the destination
 - Two-dimensional (connection oriented): decision depends on the source and destination

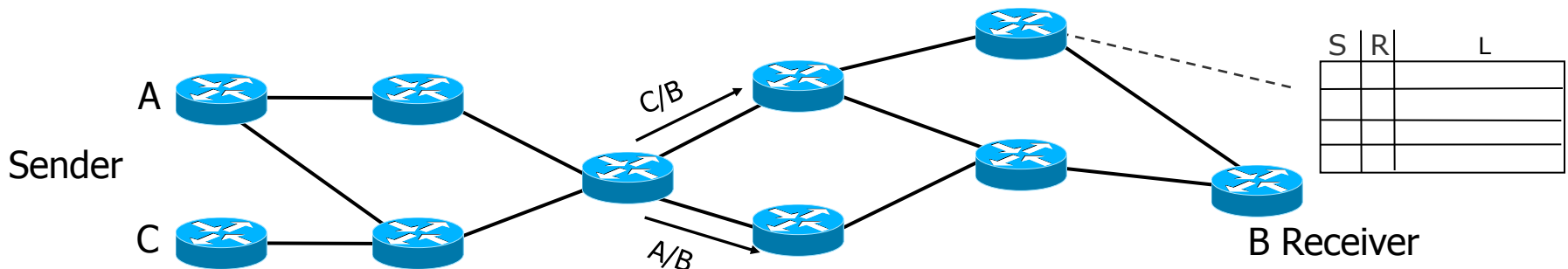

Routing - Connectionless

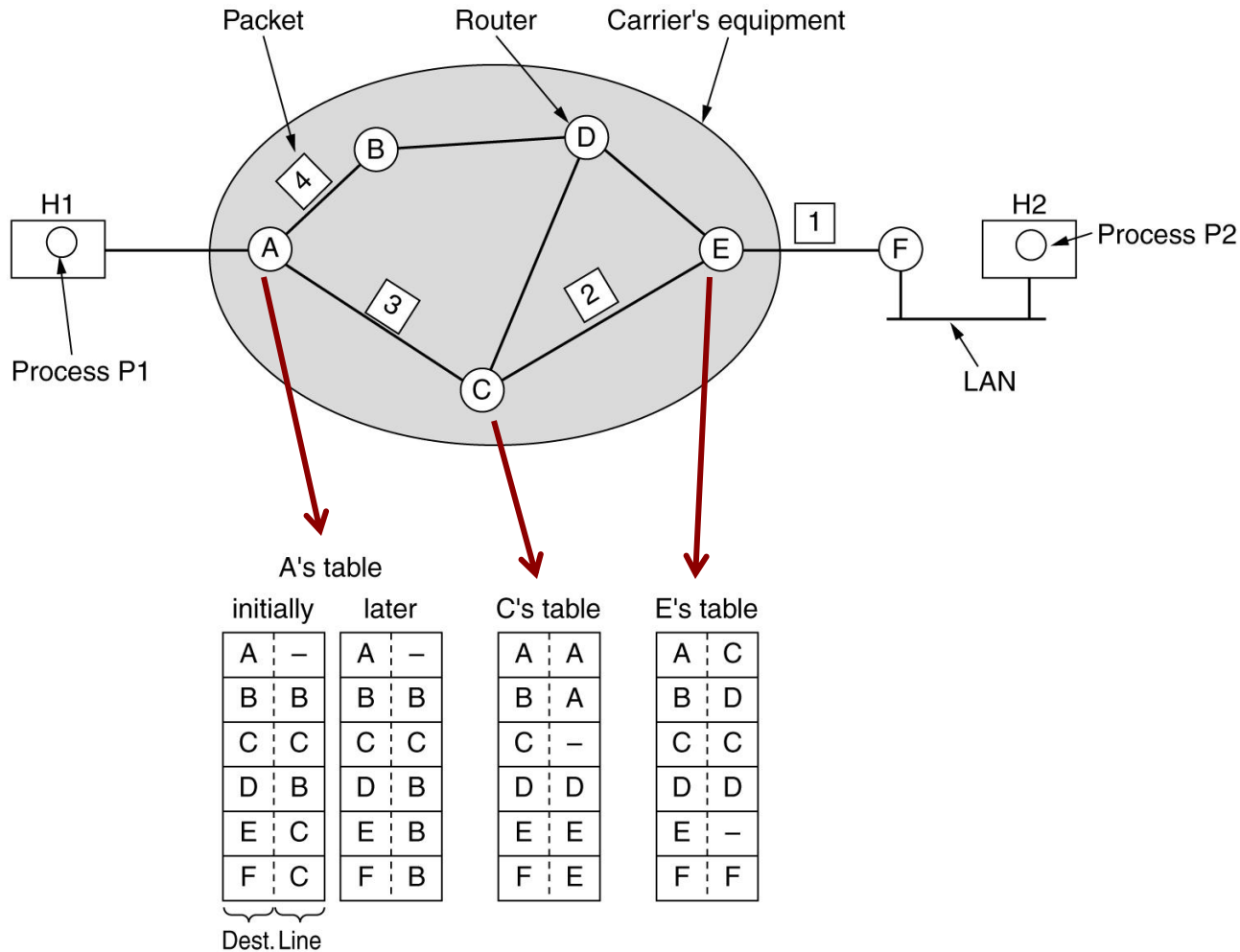

Routing - Connection-oriented

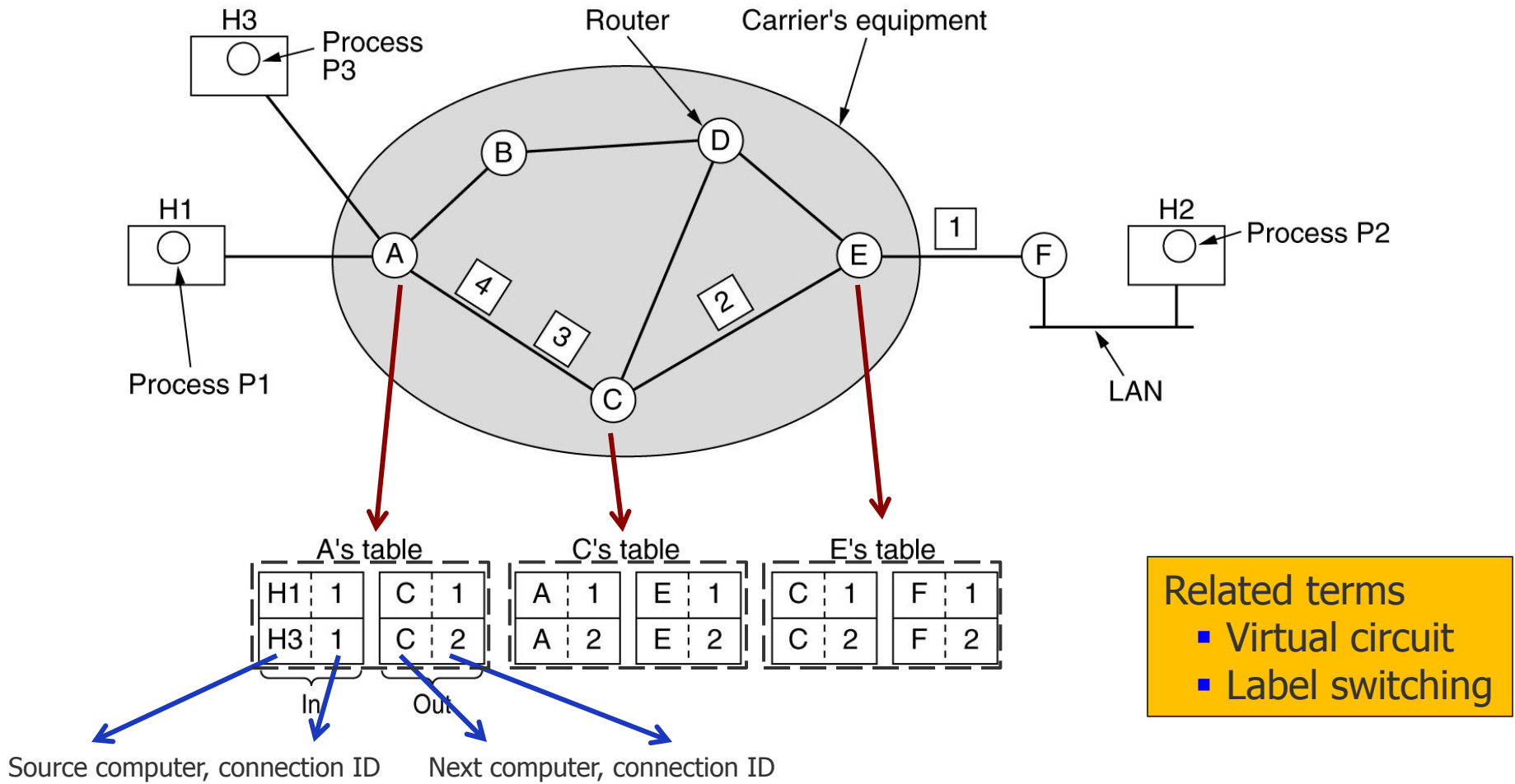



Routing – Comparison

Issue	Connectionless Datagram Subnet	Connection-oriented Virtual-circuit Subnet
<u>Circuit setup</u>	Not needed	Required
Addressing	Each packet contains the full source and destination address	Each packet contains a short VC ID
State information	Routers do not hold state information about connections	Each VC requires router table space per connection
Routing	Each packet is routed independently	Route chosen when VC is set up; all packets follow it
Effect of router failures	None, except for packets lost during the crash	All VCs that passed through the failed router are terminated
Quality of service	Difficult	Easy if enough resources can be allocated in advance for each VC
Congestion control	Difficult	Easy if enough resources can be allocated in advance for each VC

“Optimal” Routing

- “Optimal” route decision is in principle not possible, because
 - no complete information about the network is present within the individual nodes
 - a routing decision effects the network for a certain period
 - conflicts between fairness and optimum can arise

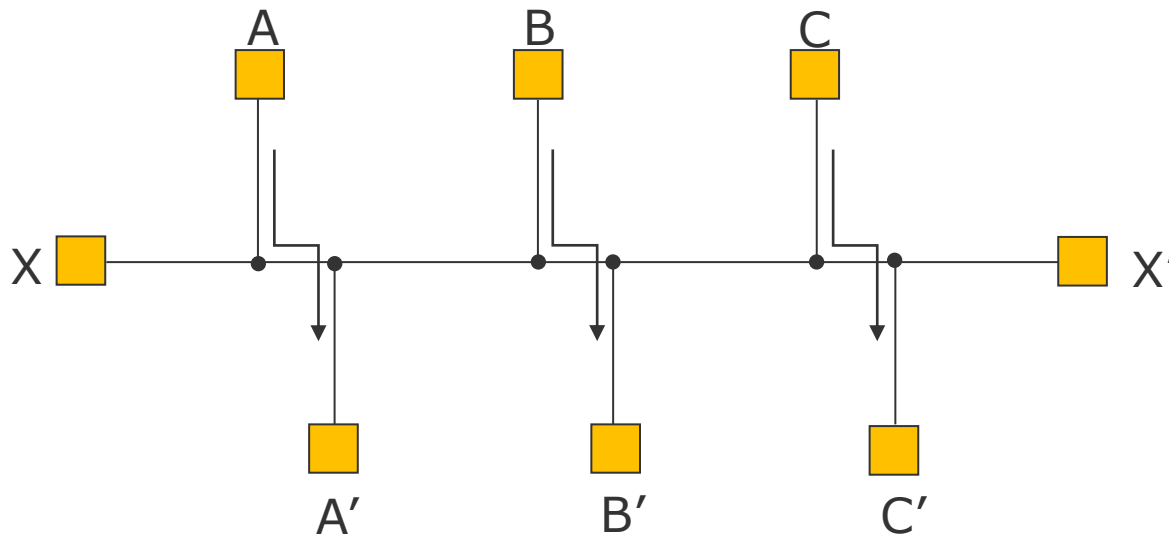

- **High traffic amount between A and A', B and B', C and C'**
- **In order to optimize the total data flow, no traffic may occur between X and X'**
- **X and X' would see this totally different!**
- ➔ **fairness criteria!**

The Optimality Principle

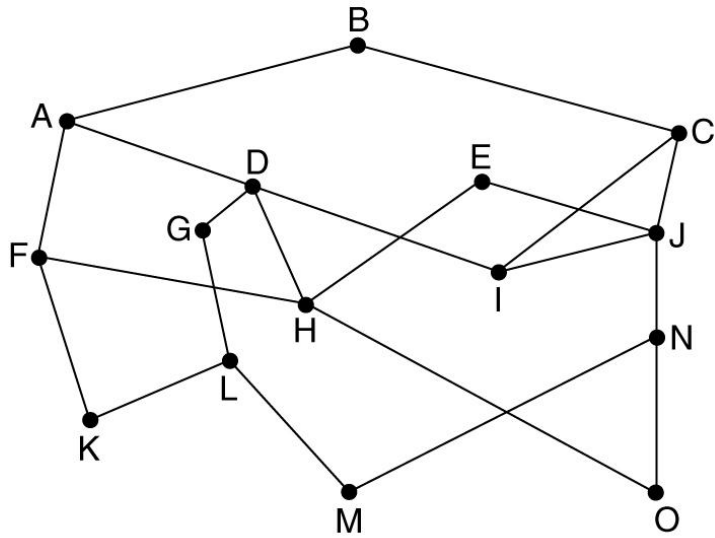

A subnet

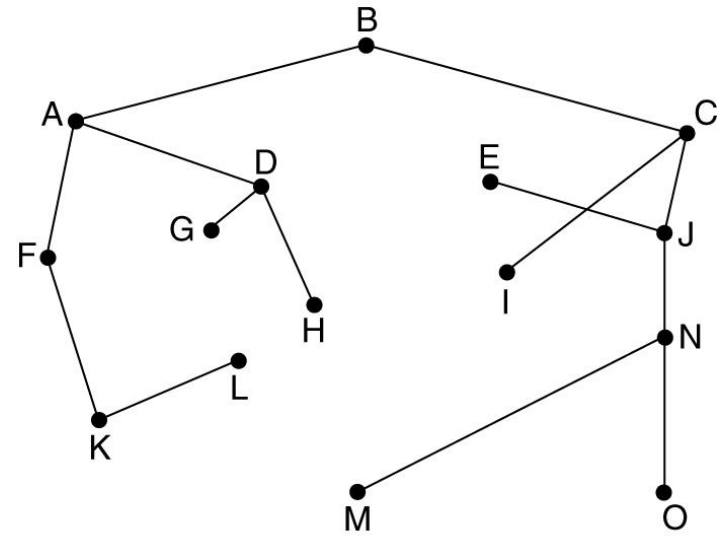

A sink tree for router B

Congestion Control

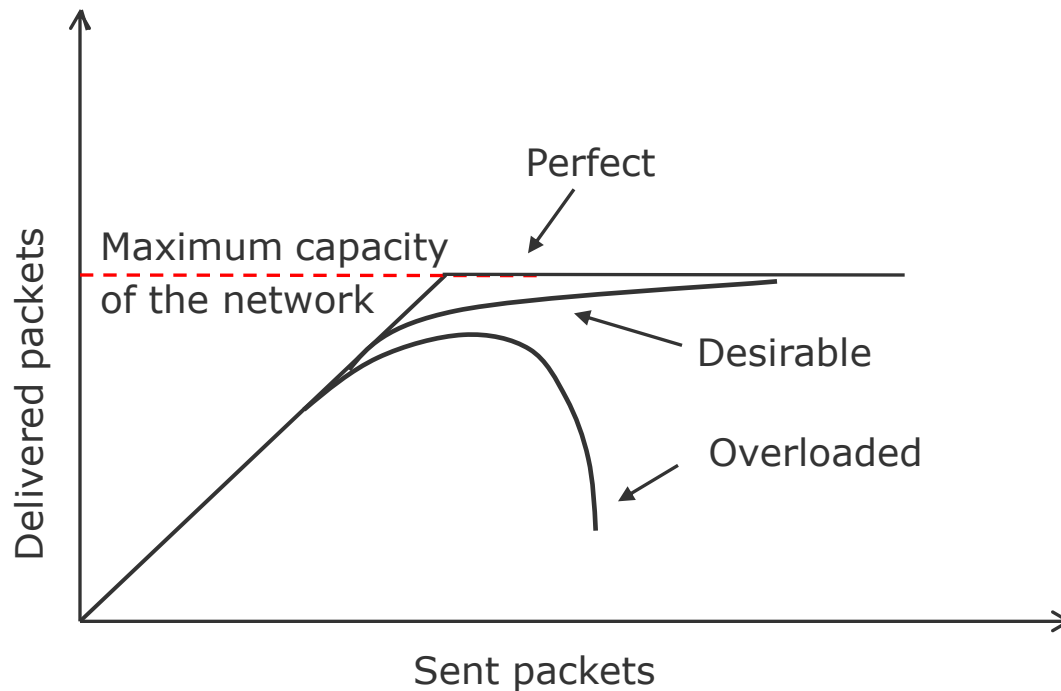

With excessive traffic, the performance of the network decreases rapidly

Parameters for detecting overload:

- Average length of the router queues
- Portion of the discarded packets in a router
- Number of packets in a router
- Number of packet retransmissions
- Average transmission delay from the sender to the receiver
- Standard deviation of the transmission delay

Solution: “smoothing” of the traffic amount, i.e., adjustment of the data rate.

➔ **Traffic Shaping**



Internet

On the Way to Today's Internet

- Goal:
 - Interconnection of computers and networks using uniform protocols
 - A particularly important initiative was initiated by the ARPA (Advanced Research Project Agency, with military interests)
 - The participation of the military was the only sensible way to implement such an ambitious and extremely expensive project
 - The OSI specification was still in developing phase
- Result: ARPANET (predecessor of today's Internet)

On the Way to Today's Internet

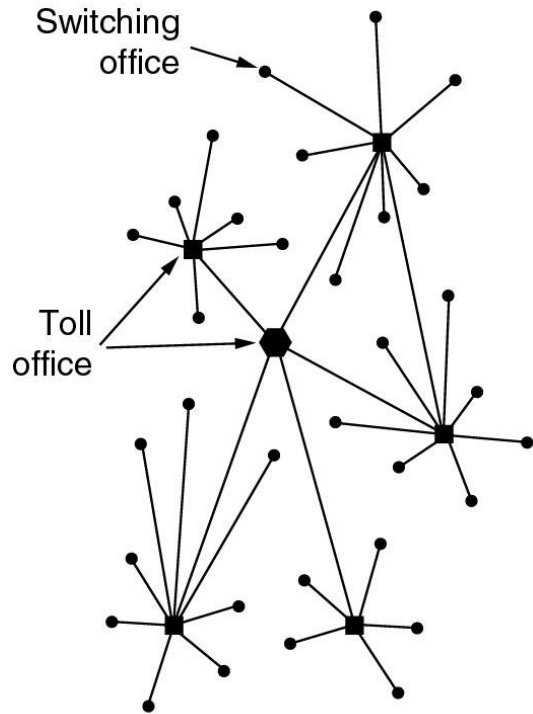

Structure of the telephone system.

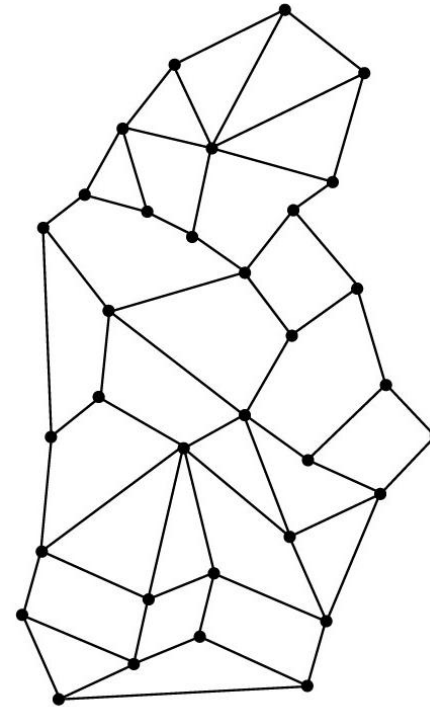

Baran's proposed distributed switching system.

ARPANET

Design objective for ARPANET

- The operability of the network should remain intact even after a large disaster, e.g., a nuclear war, thus **high connectivity** and **connectionless transmission**
- Network computers and host computers are separated

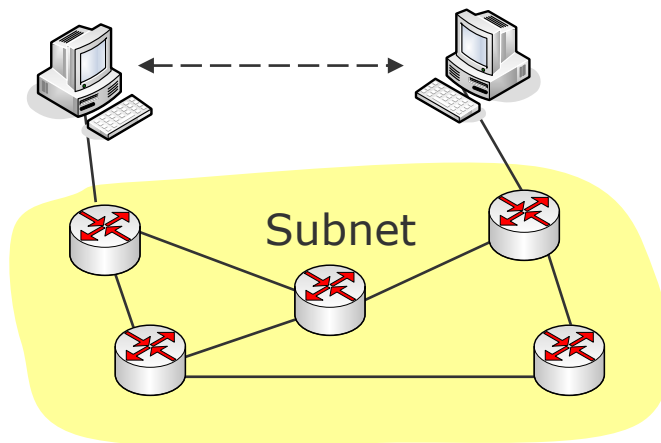

ARPANET

A **node** consists of

- an IMP
- a host

A **subnet** consists of:

- Interface Message Processors (IMPs), which are connected by leased transmission circuits
- High connectivity (in order to guarantee the demanded reliability)

Several **protocols** for the communication between IMP-IMP, host-IMP,...

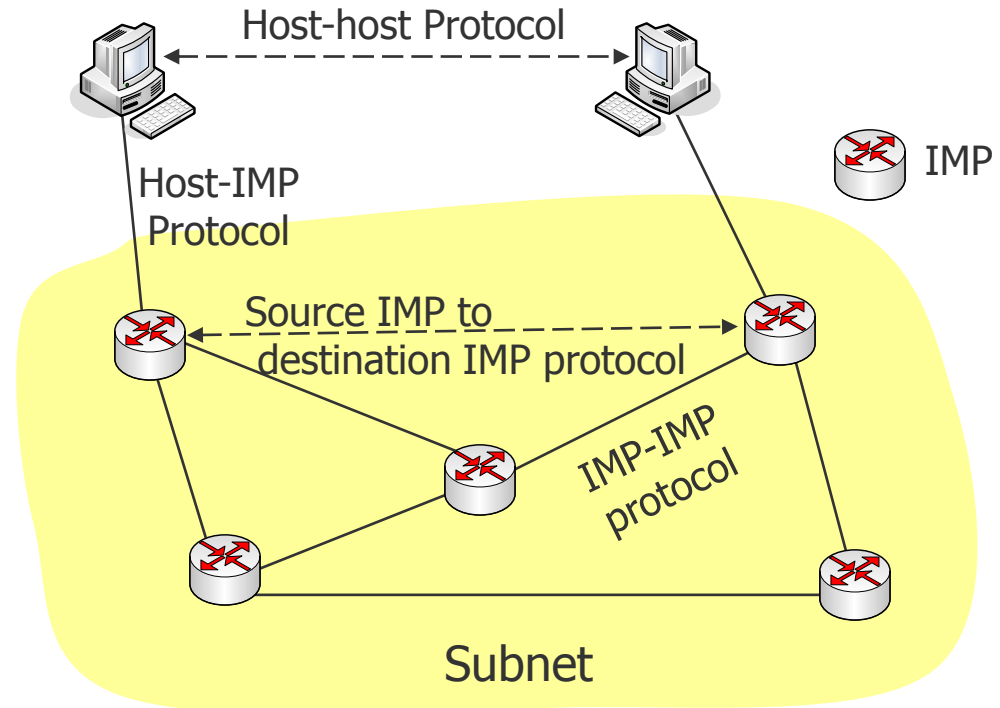

The Beginning of ARPANET

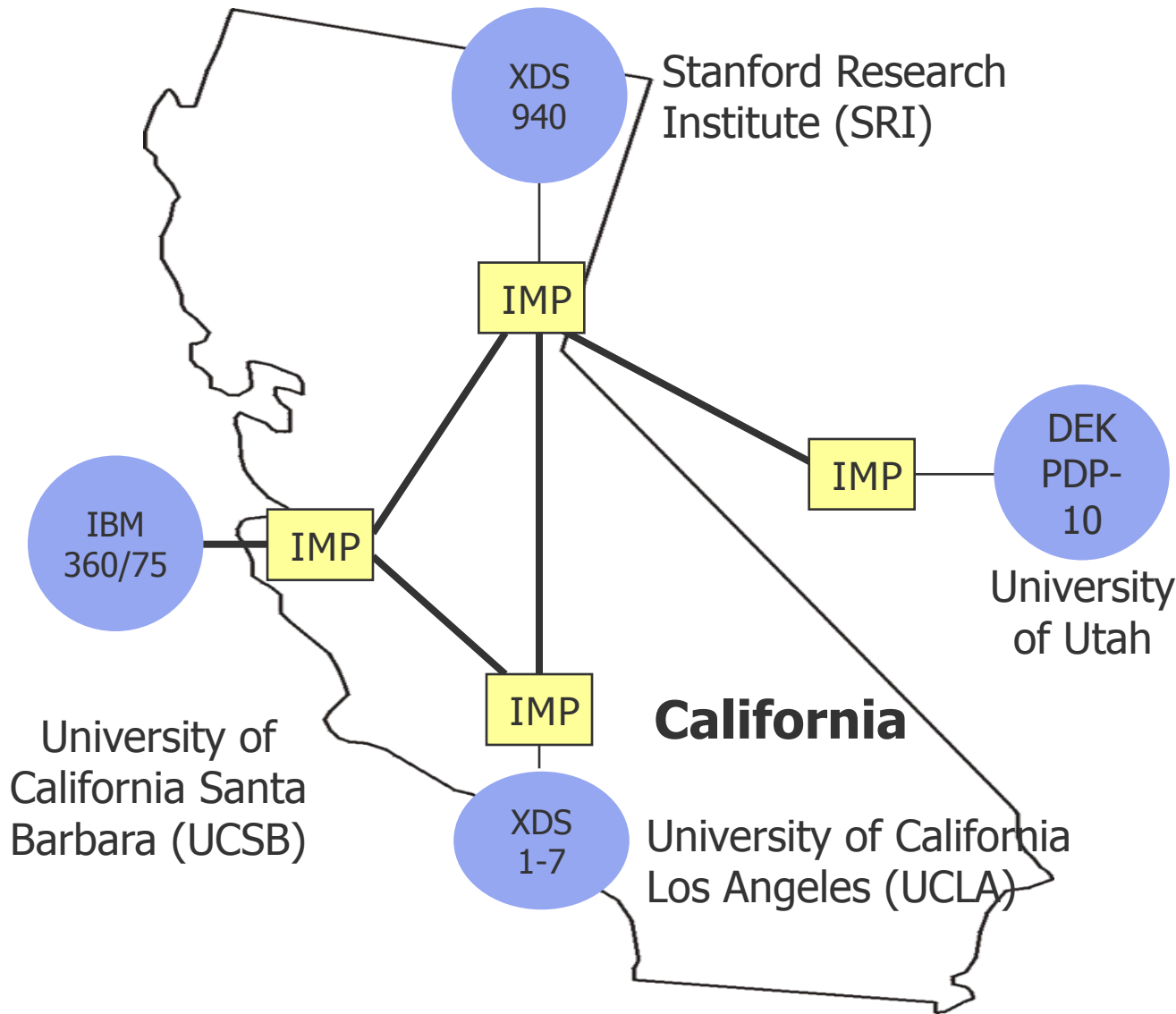

ARPANET
(December 1969)

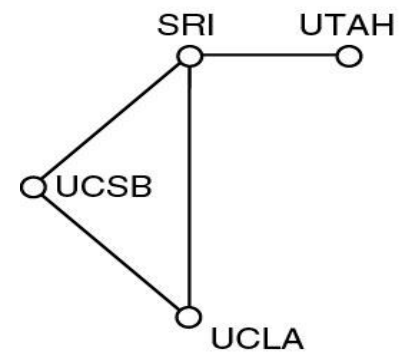

Evolution by ARPANET

Very fast evolution of the ARPANET within shortest time:

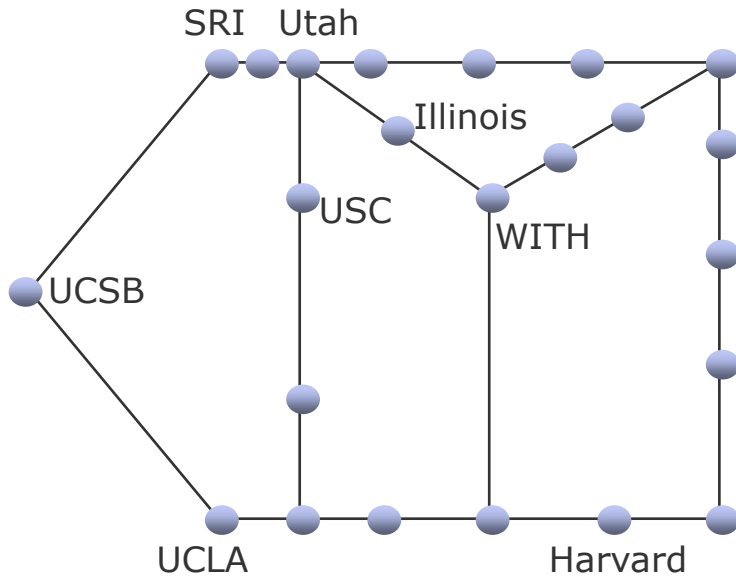

ARPANET in April 1972

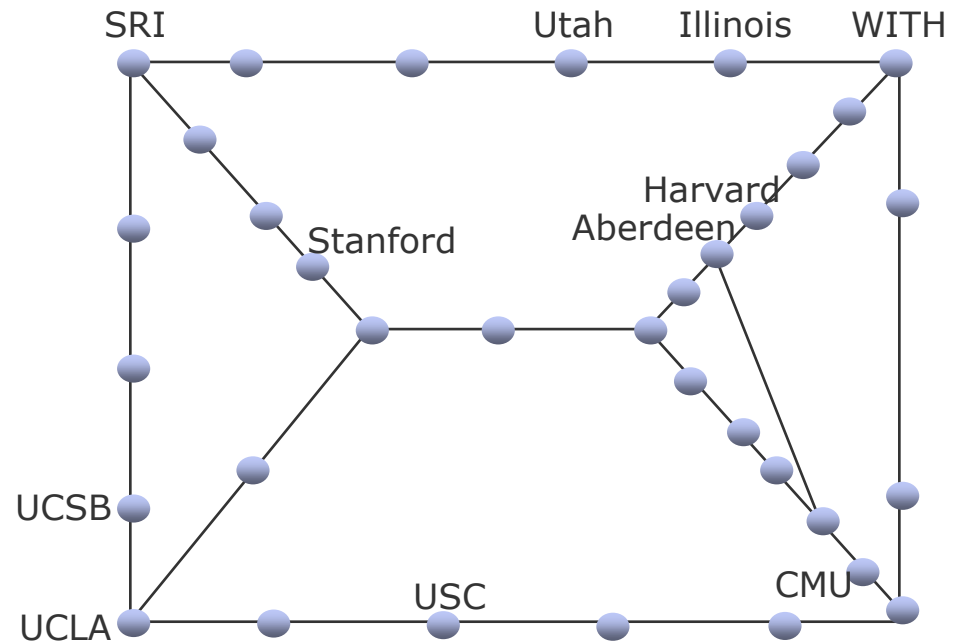

ARPANET in September 1972

Interworking

- Problem: Interworking!
 - Simultaneously to the ARPANET other (smaller) networks were developed
- All the LANs, MANs, WANs, ...
 - had different protocols, media, ...
 - could not be interconnected at first and were not be able to communicate with each other
- Therefore:
 - Development of uniform protocols on the transport- and network level
 - without a too accurate definition of these levels, in particular without exact coordination with the respective OSI levels
 - Result: **TCP/IP networks**

TCP/IP

- Developed 1974:
 - Transmission Control Protocol/Internet Protocol (TCP/IP)
- Requirements:
 - Fault tolerance
 - Maximum possible reliability and availability
 - Flexibility, i.e., suitability for applications with very different requirements
- The result:
 - Network protocol
 - Internet Protocol (IP), connectionless
 - End-to-end protocols
 - Transmission Control Protocol (TCP), connection-oriented
 - User Datagram Protocol (UDP), connectionless

TCP/IP and the OSI Reference Model

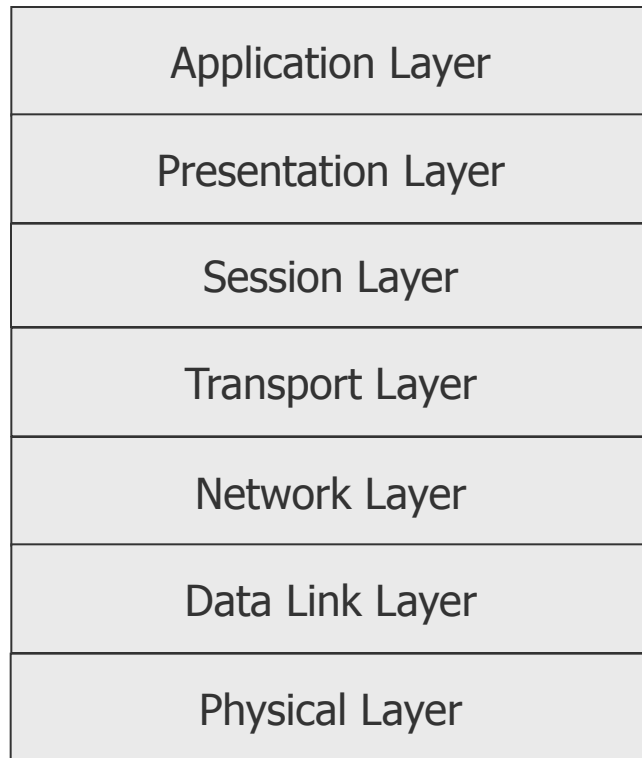

ISO/OSI

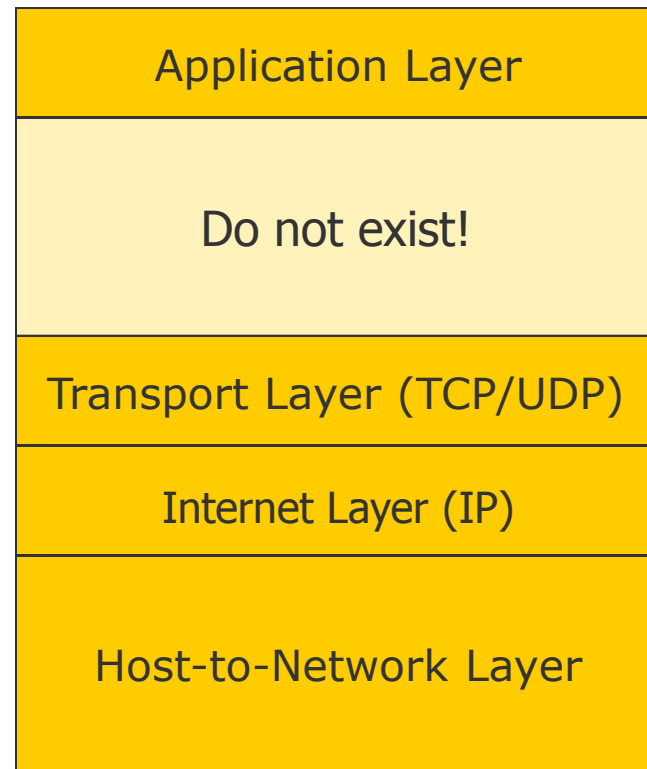

TCP/IP

From the ARPANET to the Internet

- 1983 TCP/IP became the official protocol of ARPANET
 - ARPANET was connected with many other USA networks
- Intercontinental connecting with networks in Europe, Asia, Pacific
- The total network evolved this way to a world-wide available network (called "Internet") and gradually lost its early militarily dominated character
- No central administrated network, but a world-wide union from many individual, different networks under local control (and financing)
- 1990 the Internet consisted of 3,000 networks with 200,000 computers. That was however only the beginning of a rapid evolution

Evolution of the Internet

- Until 1990: the Internet was comparatively small, only used by universities and research institutions
- 1990: The WWW (World Wide Web) became the “killer application”
 - ➔ breakthrough for the acceptance of the Internet
 - developed by CERN for the simplification of communication in the field of high-energy physics
 - HTML as markup language and Netscape as web browser
- Emergence of so-called Internet Service Providers (ISP)
 - Companies that provide access points to the Internet
- Millions of new users, predominantly non-academic!
- New applications, e.g., E-Commerce, E-Learning, E-Governance, ...
- 1995: Backbones, ten thousands LANs, millions attached computers, exponentially rising number of users
- 1998: The number of attached computers is doubled approx. every 6 months
- 1999: The transferred data volume is doubled in less than 4 months

Evolution of the Internet

Internet Domain Survey Host Count

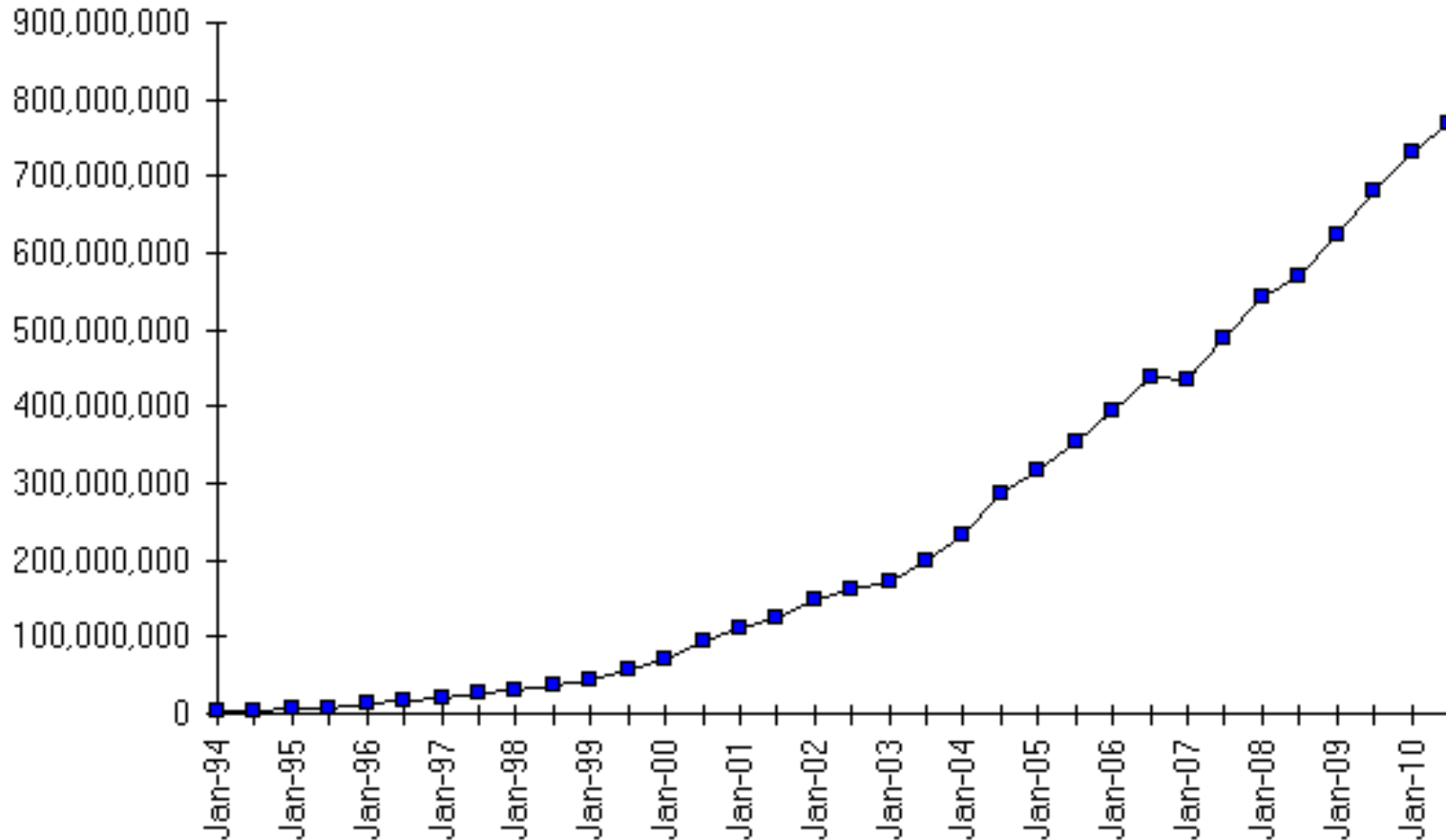

Source: Internet Systems Consortium (www.isc.org)



Evolution in Germany

.de Domains
Stand: Oktober 2010

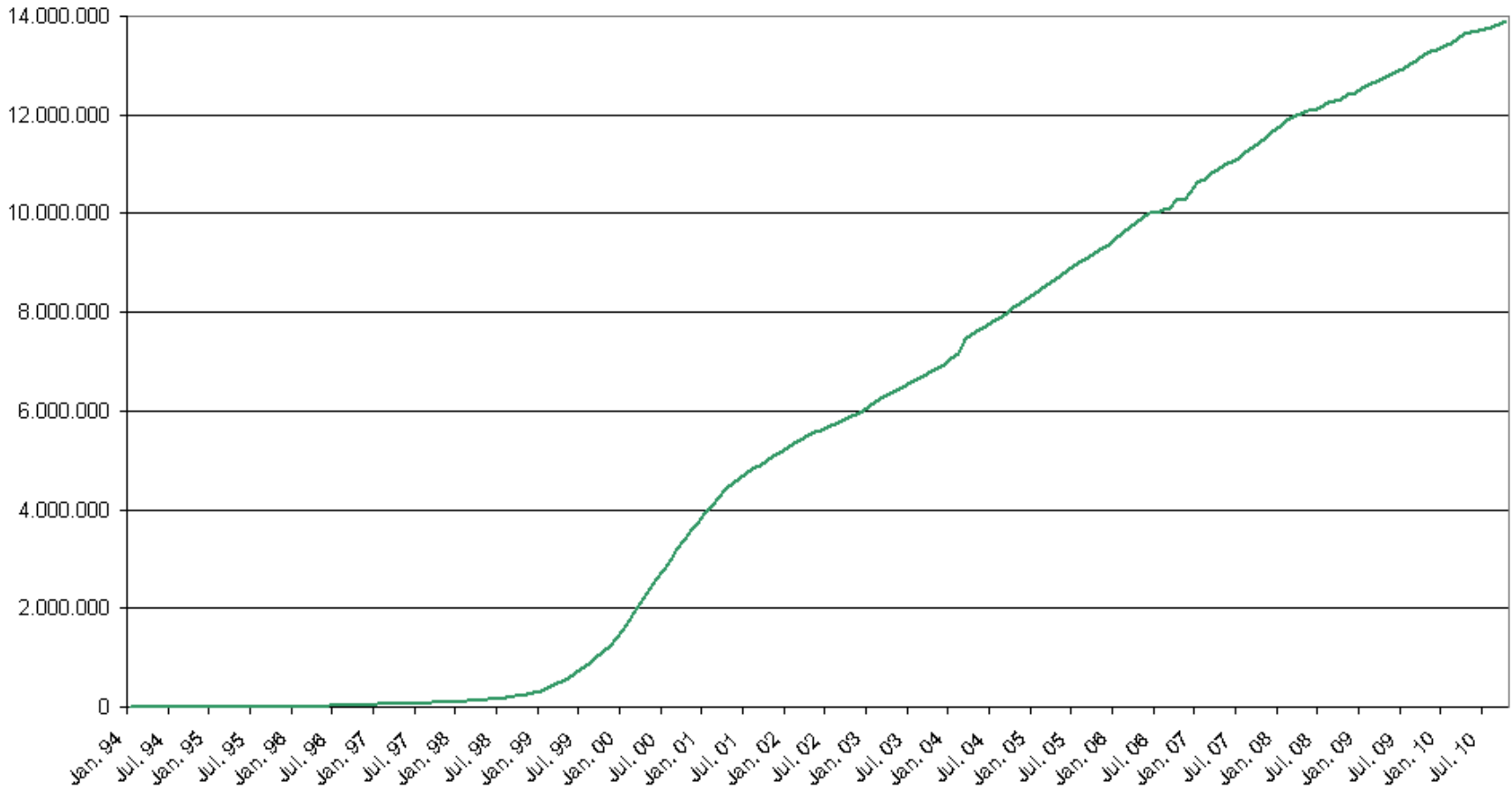

<http://www.denic.de/hintergrund/statistiken.html>

Internet

- What does it mean: “a computer is connected to the Internet”?
 - Use of the TCP/IP protocol suite
 - Accessibility over a global IP address
 - Ability to send IP packets

- In its early period, the Internet was limited to the following applications:
 - Remote login
 - Running jobs on external computers
 - File transfer
 - Exchange of data between computers
 - E-mail
 - Electronic mail

Internet vs. Intranet

● Internet

- Communication via the TCP/IP protocols
- Local operators control and finance
- Global coordination by some organizations
- Internet Service Providers (ISP) provide access points for private individuals

● Intranet

- Enterprise-internal communication with the same protocols and applications as in the Internet
- Computers are sealed off from the global Internet (security)
- Heterogeneous network structures from different branches can be integrated with TCP/IP easily
- Use of applications like in the WWW for internal data exchange

The classical TCP/IP Protocol Suite

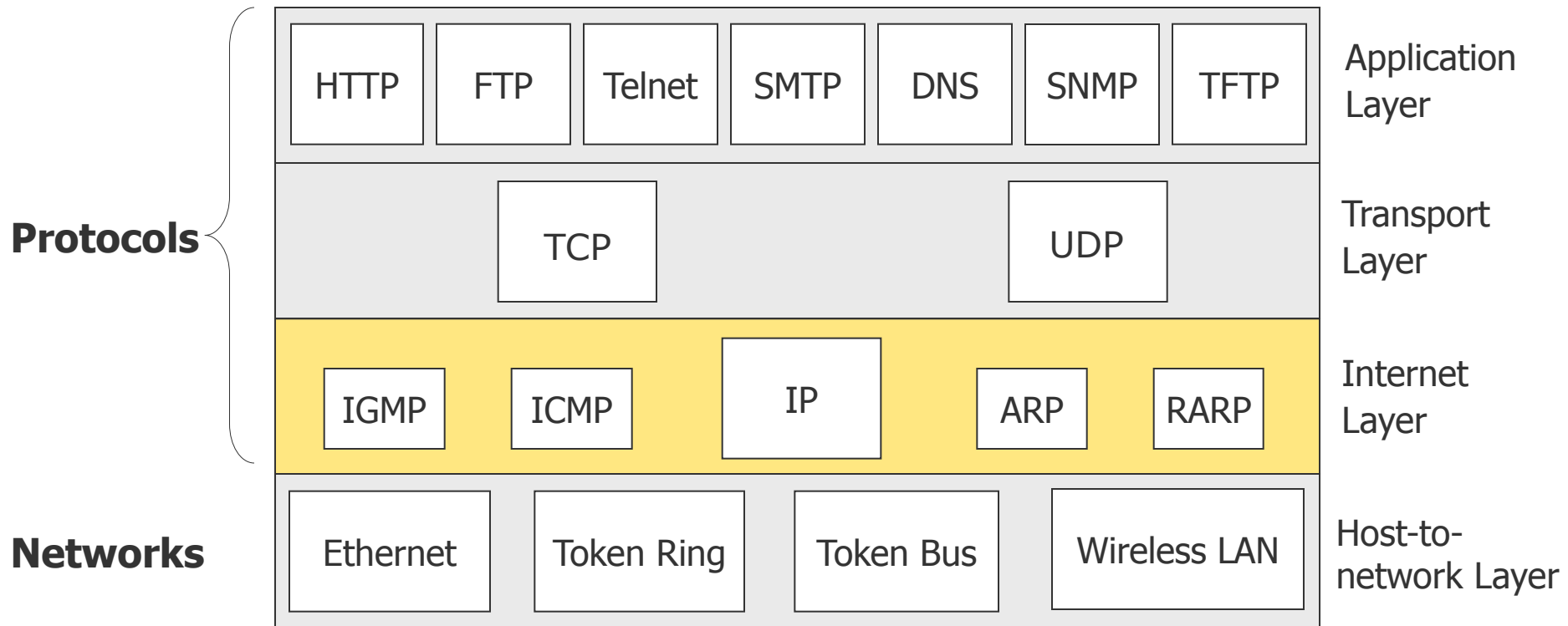

Classical Sandglass Model

- Sandglass model
 - Small number of central protocols
 - Large number of applications and communication networks

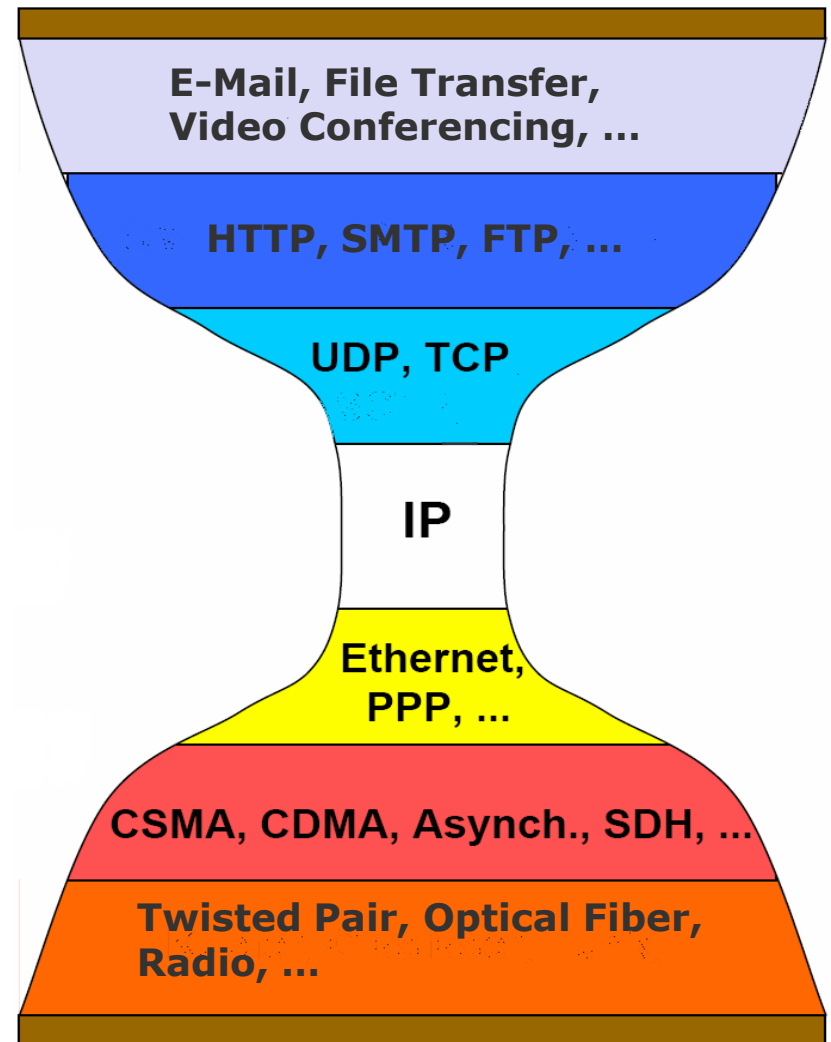

Internet Protocol (IP)

Internet Layer

- Raw division into three tasks:
 - Data transfer over a global network
 - Route decision at the sub-nodes
 - Control of the network or transmission status

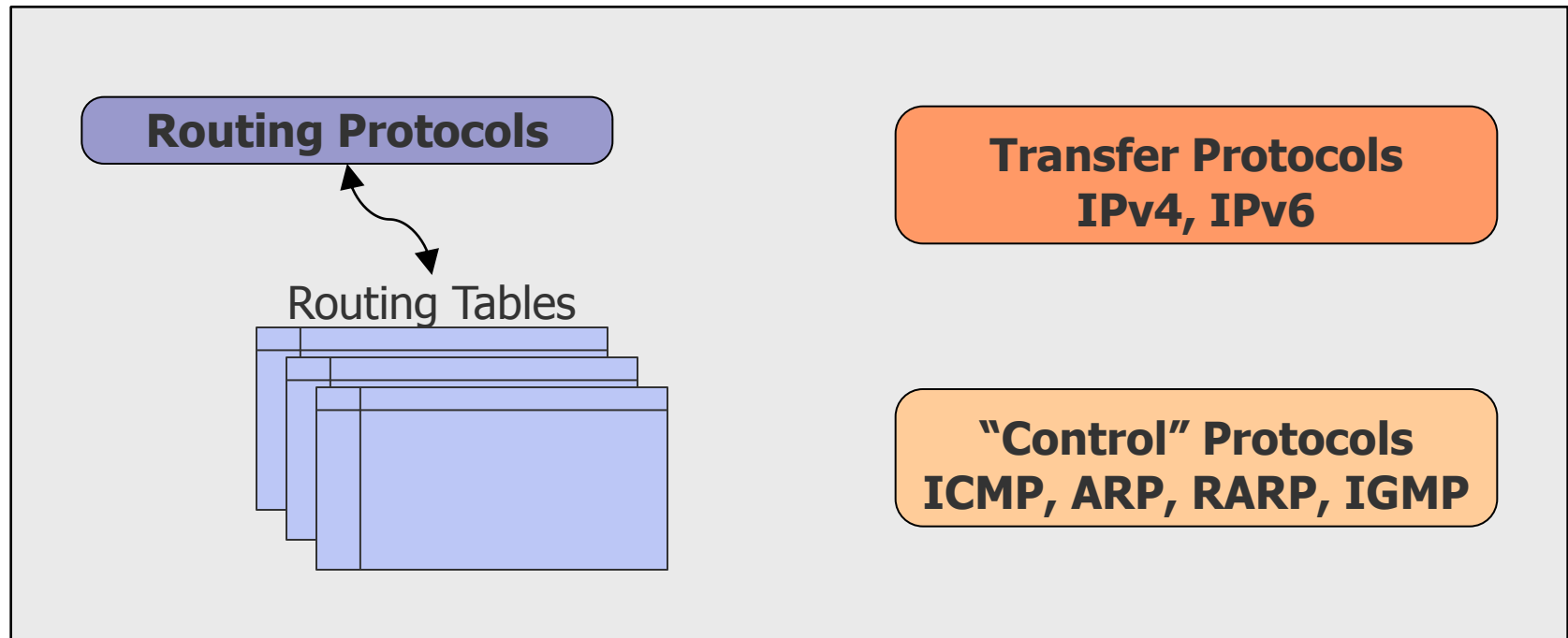

Internet Protocol (IP)

- IP: connectionless, unreliable transmission of datagrams/packets
 - ➔ “Best Effort” Service
 - Transparent end-to-end communication between the hosts
 - Routing, interoperability between different network types
 - IP addressing (IPv4)
 - Uses logical 32-bit addresses
 - Hierarchical addressing
 - 3 network classes
 - 4 address formats (including multicast)
 - Fragmenting and reassembling of packets
 - Maximum packet size: 64 kByte
 - In practice: 1500 byte
 - At present commonly used: Version 4 of IP (IPv4)

IP Packet

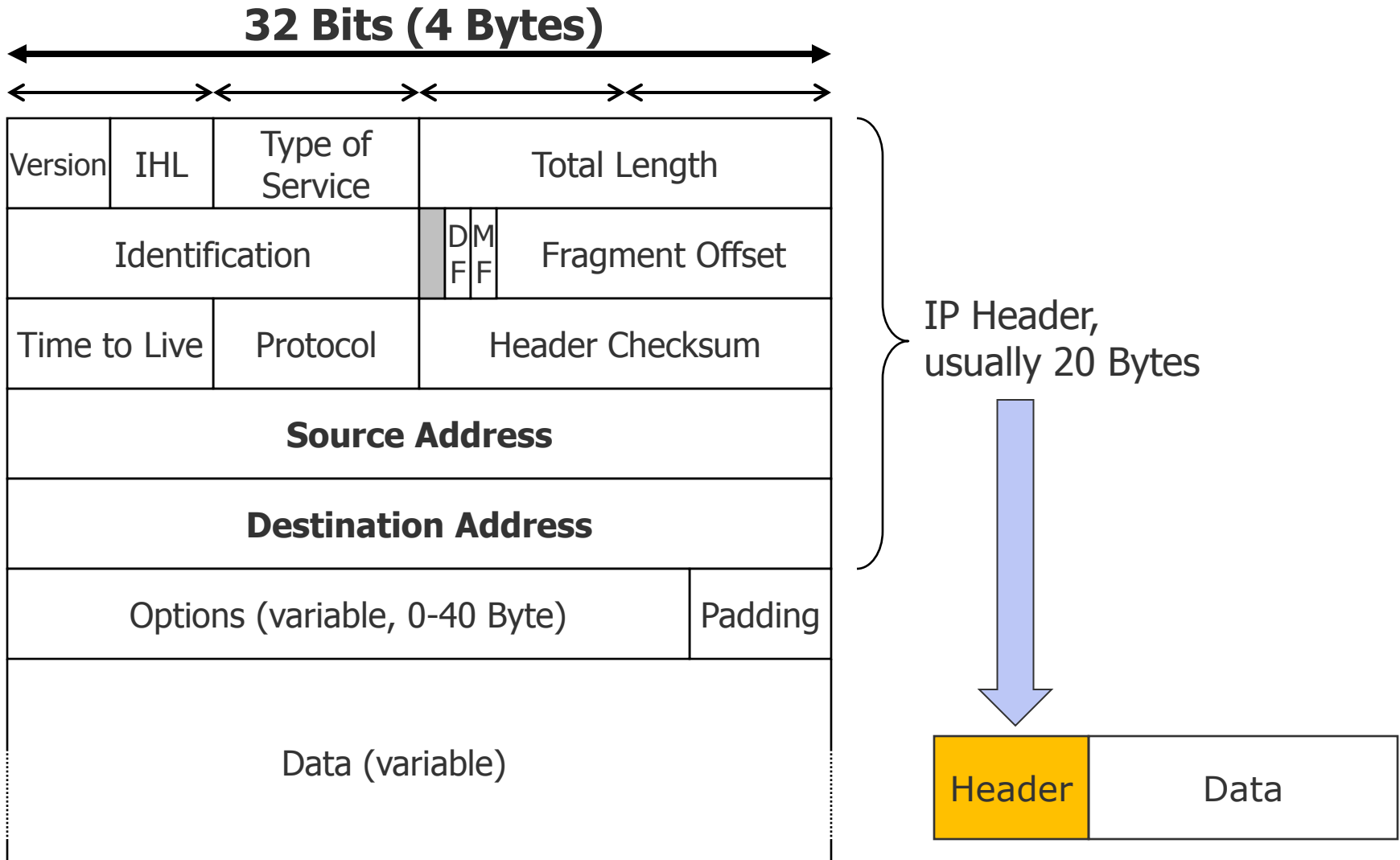



The IP Header (1)

- **Version** (4 bits): IP version number (for simultaneous use of several IP versions)
- **IHL** (4 bits): IP Header Length (in words of 32 bit; between 5 and 15, depending upon options)
- **Type of Service** (8 bits): Indication of the desired service: Combination of reliability (e.g. file transfer) and speed (e.g. audio) → historical, DSCP today

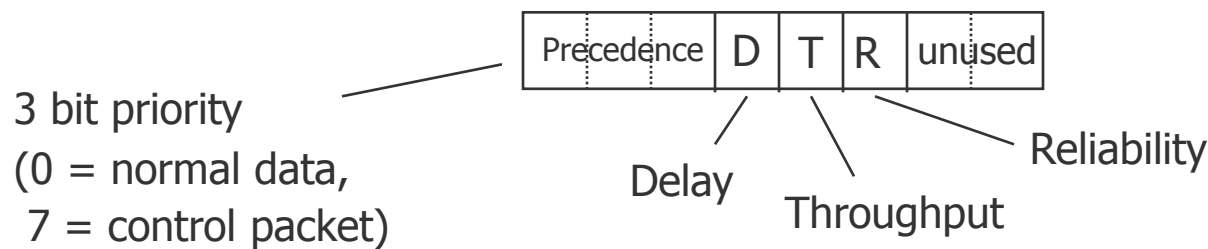

- **Total Length** (16 bits): Length of the entire packet $\leq 2^{16} - 1 = 65\,535$ bytes
- **Identification** (16 bits): definite marking of a packet
- **Time to Live** (TTL, 8 bits):
 - To prevent the endless circling of packets in the network maximum of 255 hops.
 - In principle, the processing time in routers has to be compensated in practice. The counter is **reduced with each hop**, with

Version	IHL	Type of Service	Total Length	
Identification			DM FF	Fragment Offset
Time to Live		Protocol	Header Checksum	
Source Address				
Destination Address				
Options (variable, 0-40 Byte)				Padding
DATA (variable)				

The IP Header (2)

- **DF** (1 bit): Don't Fragment. All routers must forward packets up to a size of 576 byte, everything beyond that is optional. Larger packets with set DF-bit therefore cannot take each possible way in the network.
- **MF** (1 bit): More Fragments
 - "1" - further fragments follow
 - "0" - last fragment of a datagram
- **Fragment Offset** (13 bits): Sequence number of the fragments of a packet ($2^{13} = 8192$ possible fragments). The offset states, to which position of a packet (counted in multiples of 8 byte) a fragment belongs to. From this a maximum length of $8192 \times 8 \text{ byte} = 65,536 \text{ byte}$ results for a packet.
- **Protocol** (8 bits): Which transport protocol is used in the data part (UDP, TCP,...)? To which transport process the packet belongs to.
- **Header Checksum** (16 bits): 1's complement of the sum of all 16-bit words of the header. Must be computed with each byte of the header.
- **Source Address/Destination Address** (32 bits): IP address of sending and receiving computer. This information is used for routing decision.

Version	IHL	Type of Service	Total Length	
Identification			DF MF	Fragment Offset
Time to Live	Protocol		Header Checksum	
Source Address				
Destination Address				
Options (variable, 0-40 Byte)				Padding
DATA (variable)				

Fragmentation

- A too large or too small packet length prevents a good performance. Additionally there are often size restrictions (buffer, protocols with length specifications, standards, allowed access time to a channel,...)
- The data length must be a multiple of 8 byte. Exception: the last fragment, only the remaining data are packed, padding to 8 byte units is not applied.
- If the "DF"-bit is set, the fragmentation is prevented.

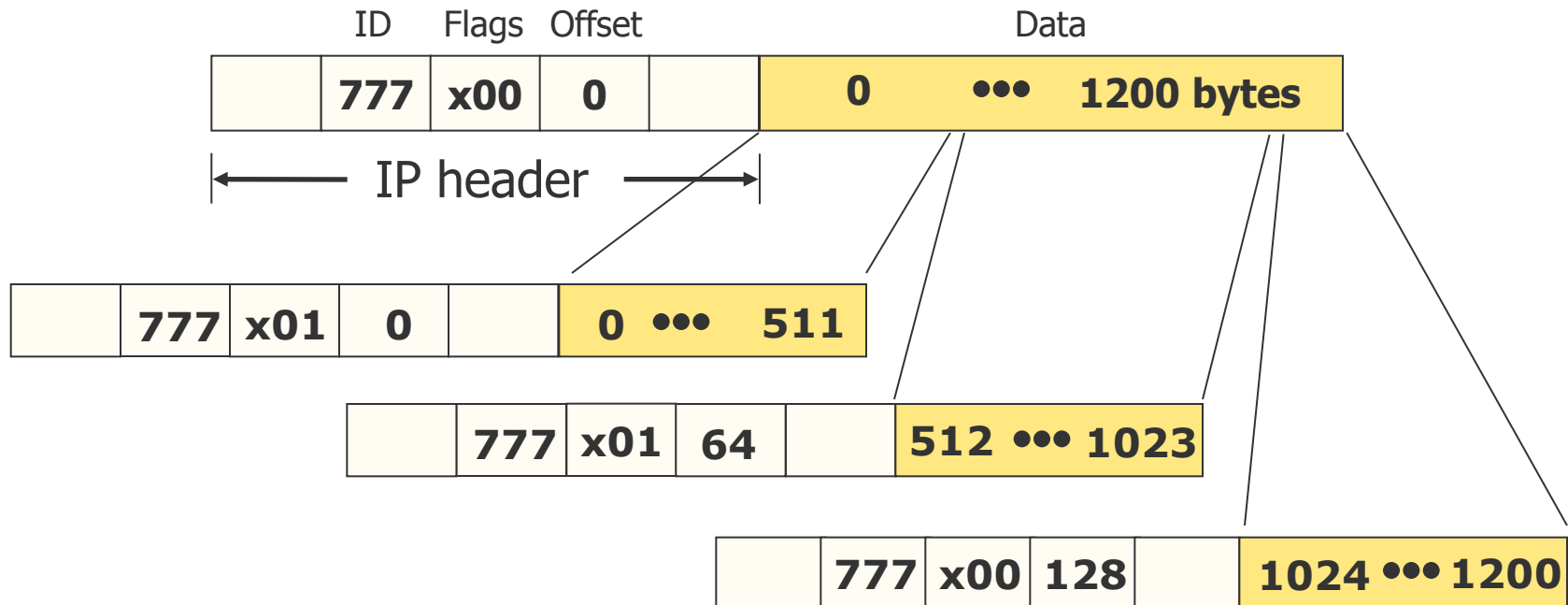

The IP Header (3)

- **Options** (≤ 40 bytes): Prepare for future protocol extensions.
 - Coverage: Multiple of 4 byte, therefore possibly padding is necessary
 - See for details: www.iana.org/assignments/ip-parameters
- Five options are defined, however none is supported by common routers:
 - **Security:** How secret is the transported information?
 - Application e.g. in military: Avoidance of crossing of certain countries/networks.
 - **Strict Source Routing:** Complete path defined from the source to the destination host by providing the IP addresses of all routers which are crossed.
 - For managers e.g. in case of damaged routing tables or for time measurements
 - **Loose Source Routing:** The carried list of routers must be passed in indicated order. Additional routers are permitted.
 - **Record Route:** Recording of the IP addresses of the routers passed.
 - Maximally 9 IP addresses possible, nowadays too few.
 - **Time Stamp:** Records router addresses (32 bits) as well as a time stamp for each router (32 bits). Application e.g. in fault management.

Internet Protocol (IP)

Addressing

Classical IP Addressing

- Unique **IP address** for each host and router.
- IP addresses are 32 bits long and are used in the **Source Address** as well as in the **Destination Address** field of IP packets.
- The IP address is structured hierarchically and refers to a certain network, i.e., machines with connection to several networks have several IP addresses.
- Structure of the address: Network address for physical network (e.g. 160.45.117.0) and host address for a machine in the addressed network (e.g. 160.45.117.199)

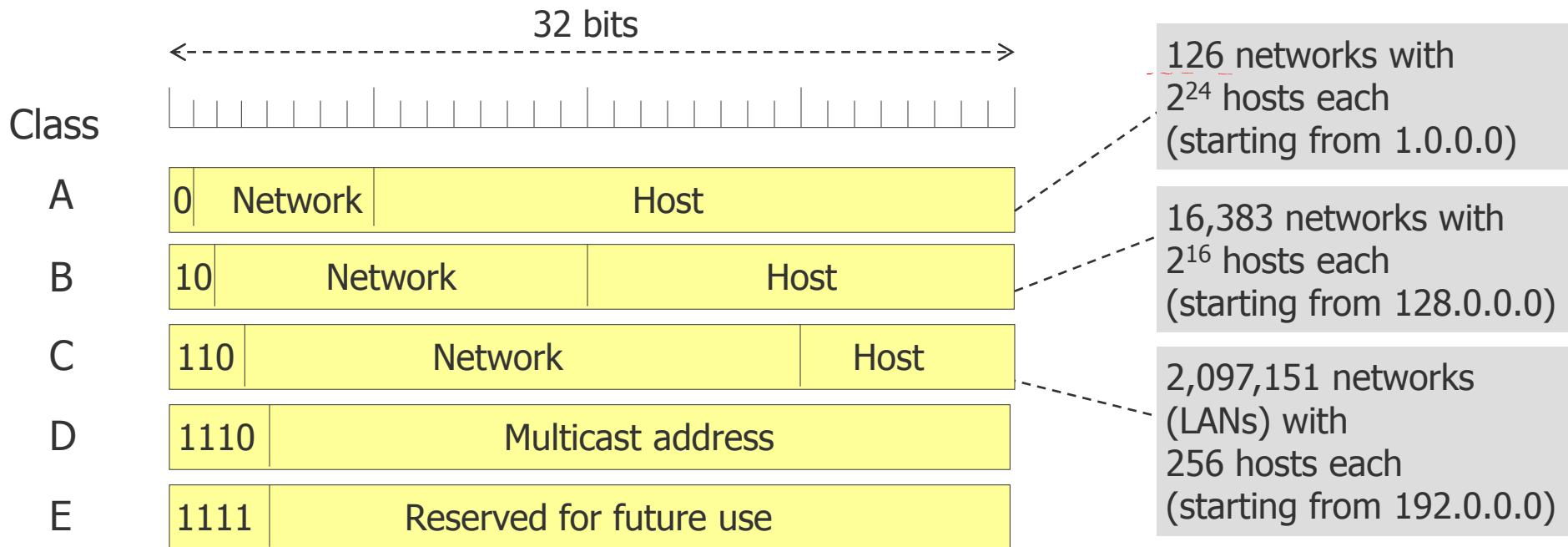

IP Addresses

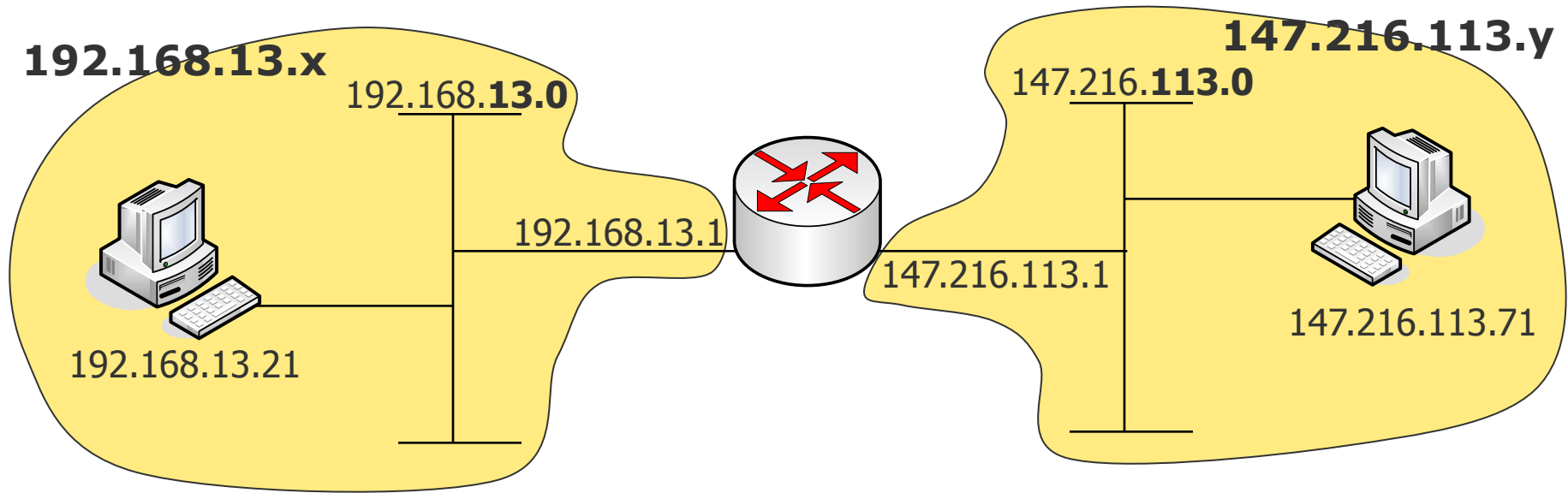

Binary format	11000000 . 10101000 . 00001101 . 00010101
Dotted Decimal Notation	192.168.13.21

- Each node has (at least) one world-wide unique IP address
- Router or gateways that link several networks, have for each network an IP address

IP Addresses and Routing

Destination IP Address	Connection	Network Interface
12.x.x.x	194.52.124.x	b
147.216.x.x	142.117.x.x	a
142.117.x.x	direct	a
194.52.124.x	direct	b
x.x.x.x	default	a

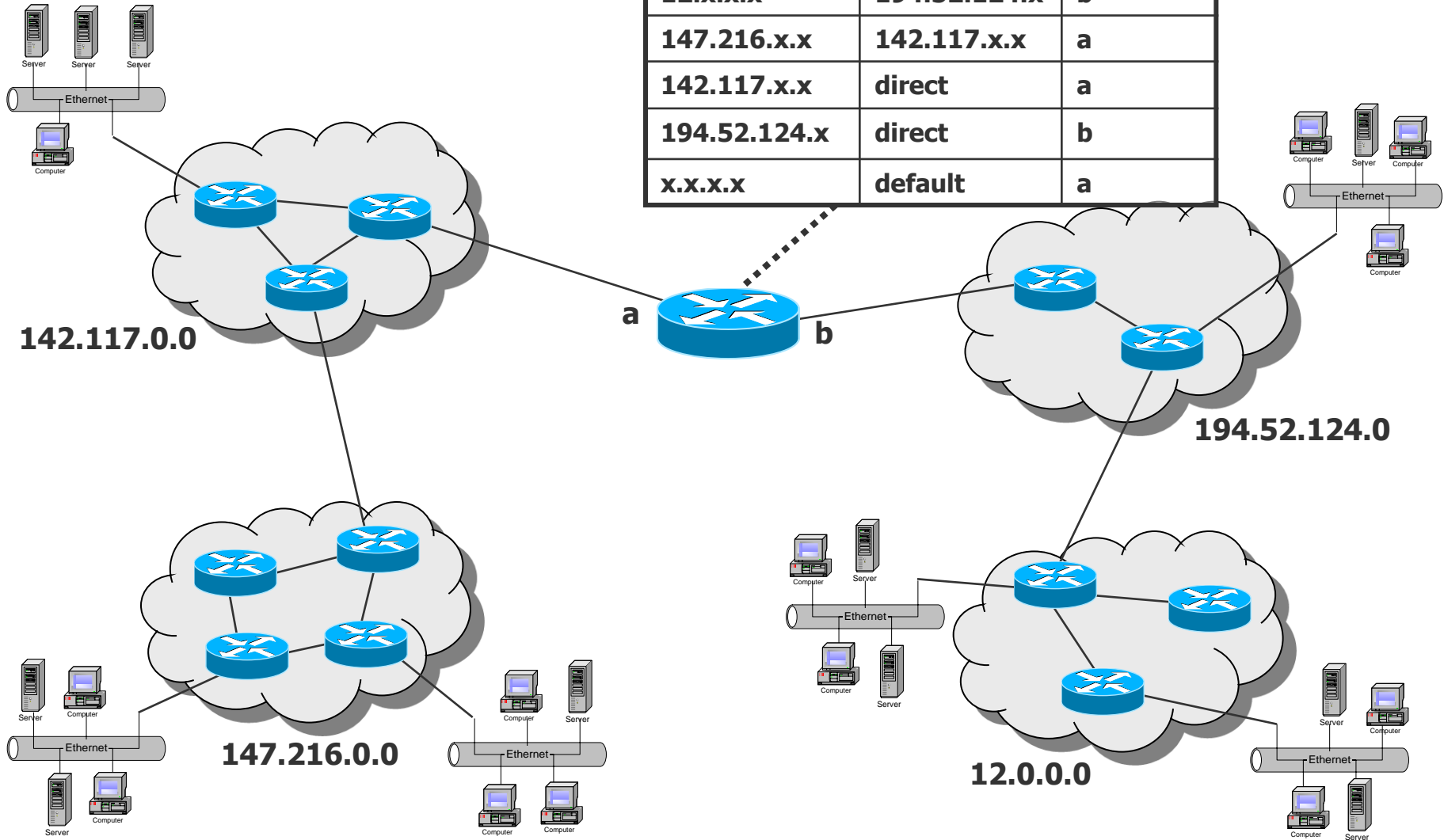

IP Addressing: Examples

The representation of the 32-bit addresses is divided into 4 sections of each 8 bits:

www.fu-berlin.de = 160.45.170.10



Special addresses:

0 0 0 0 0 0	This host
0 0 0 0 Host	Host in this network
1 1 1 1 1 1	Broadcast in own local area network
Network 1 1 1 1 1 1	Broadcast in the remote network
127 arbitrary	Local loop, no sending to the network

Address Space

Address Space

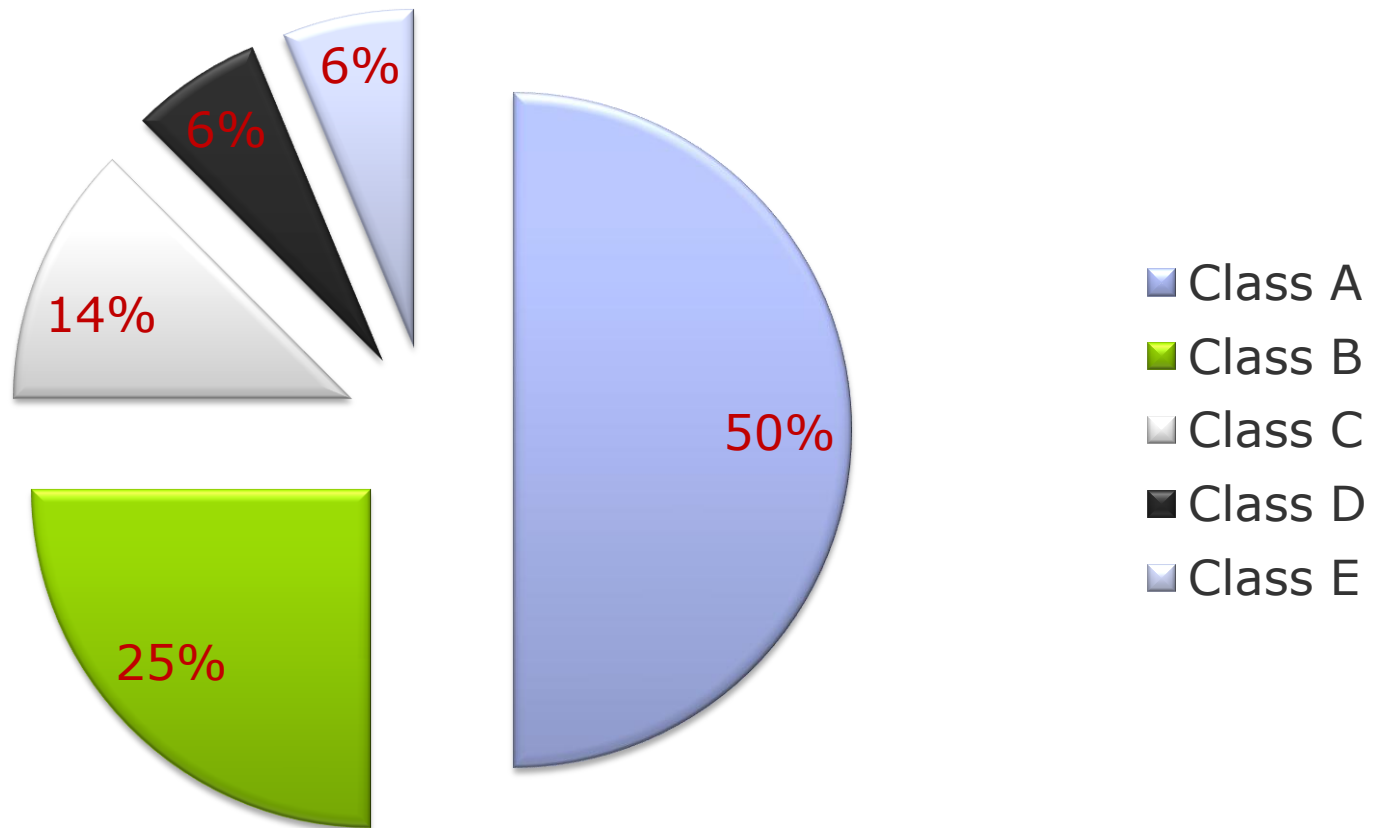

IP Addresses are scarce...

- Problems
 - Nobody had thought about the explosive growth of the Internet (otherwise one would have defined longer addresses from the beginning).
 - Too many Class A address blocks were assigned in the first Internet years.
 - Inefficient use of the address space.
 - Example: if 500 devices in an enterprise are to be attached, a Class B address block is needed, but by this unnecessarily more than 65,000 host addresses are blocked.
- Solution approach: Extension of the address space in IPv6
 - IP version 6 has 128 bits for addresses ➤ 2^{128} addresses
 - 7 x 10²³ IP addresses per square meter of the earth's surface (including the oceans!)
 - one address per molecule on earth's surface!
- But: The success of IPv6 is not by any means safe!
 - The introduction of IPv6 is tremendously difficult: Interoperability, costs, migration strategies, ...

IP Subnets

- Problem: Class C-networks (256 hosts) are very small and Class B-networks (65536 hosts) often too large
- Therefore, divide a network into **subnets**

Example for subnets: subnet mask 255.255.255.0

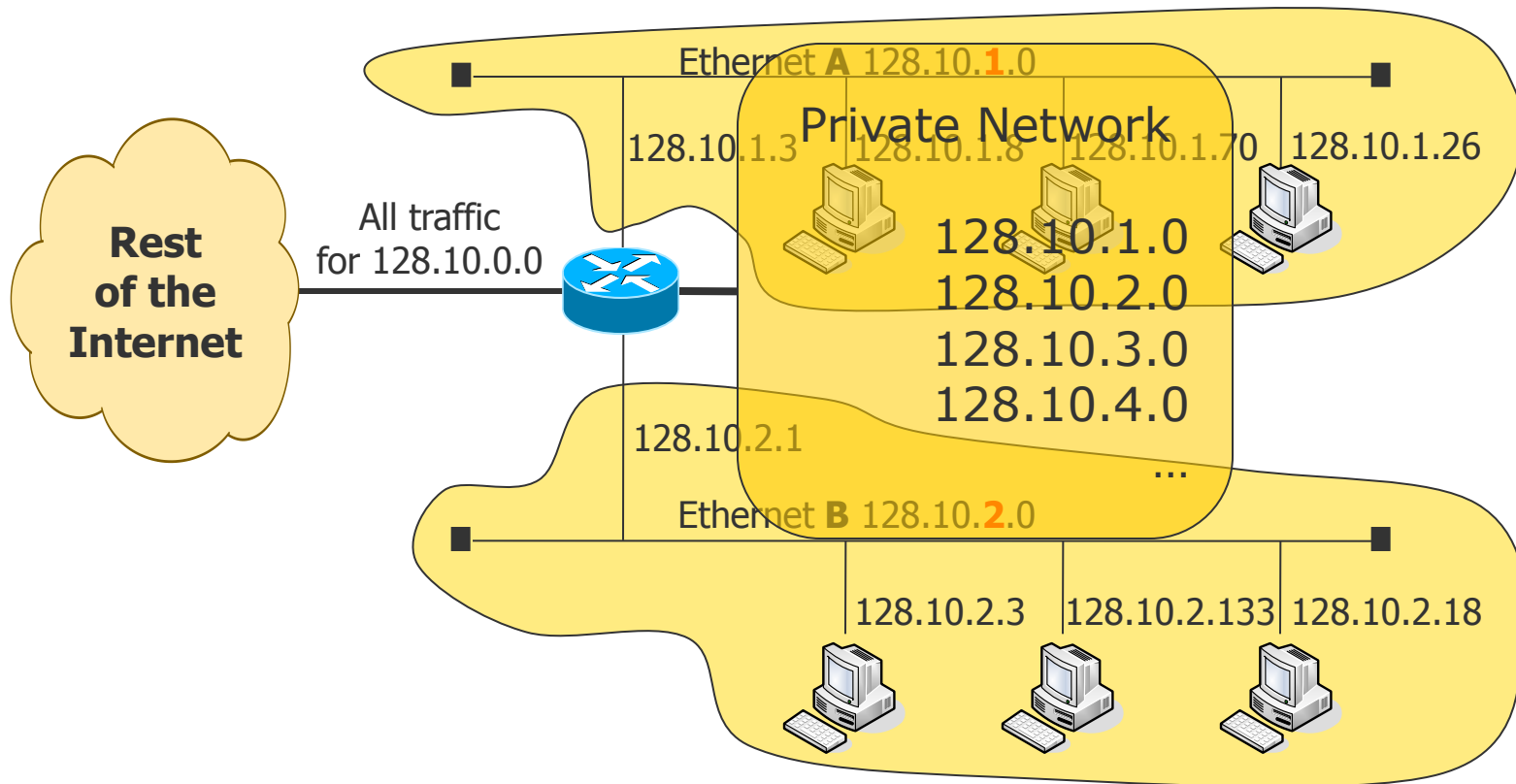

IP Subnets

- Within an IP network address block, several physical networks can be addressed
- Some bits of the host address part are used as network ID
- A Subnet Mask identifies the “abused” bits

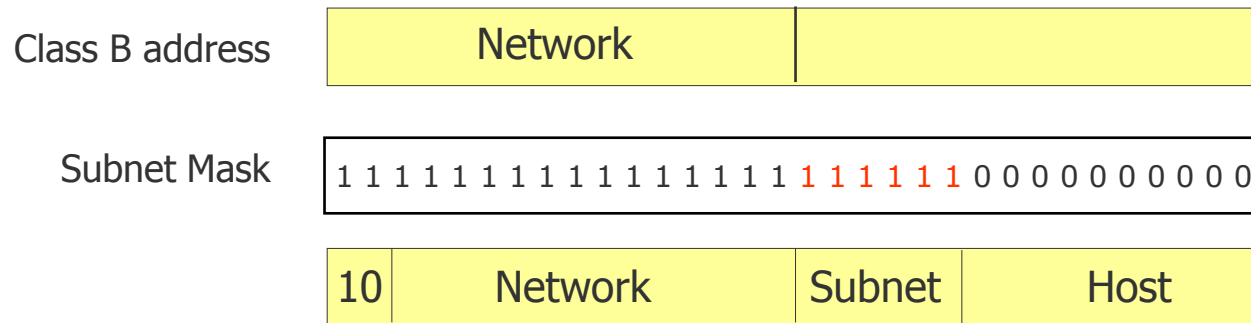

- All hosts of a network use the same subnet mask
- Routers can determine through combination of an IP address and a subnet mask, to which subnet a packet must be sent



IP Subnets: Computation of the Destination

The entrance router of the FU Berlin, which receives the IP packet, does not know, where host "117.200" is located.

	160	45	117	200
IP address	10100000	00101101	01110101	11001000

AND

	255	255	0	0
Subnet mask	1111 1111	1111 1111	0000 0000	0000 0000

	160	45	0	0
Network of the addressed host	10100000	00101101	00000000	00000000

A router computes the subnet "160.45.0.0" and sends the packet to the router, which links this subnet.



IP Subnets: Computation of the Destination

The entrance router of the FU Berlin, which receives the IP packet, does not know, where host "117.200" is located.

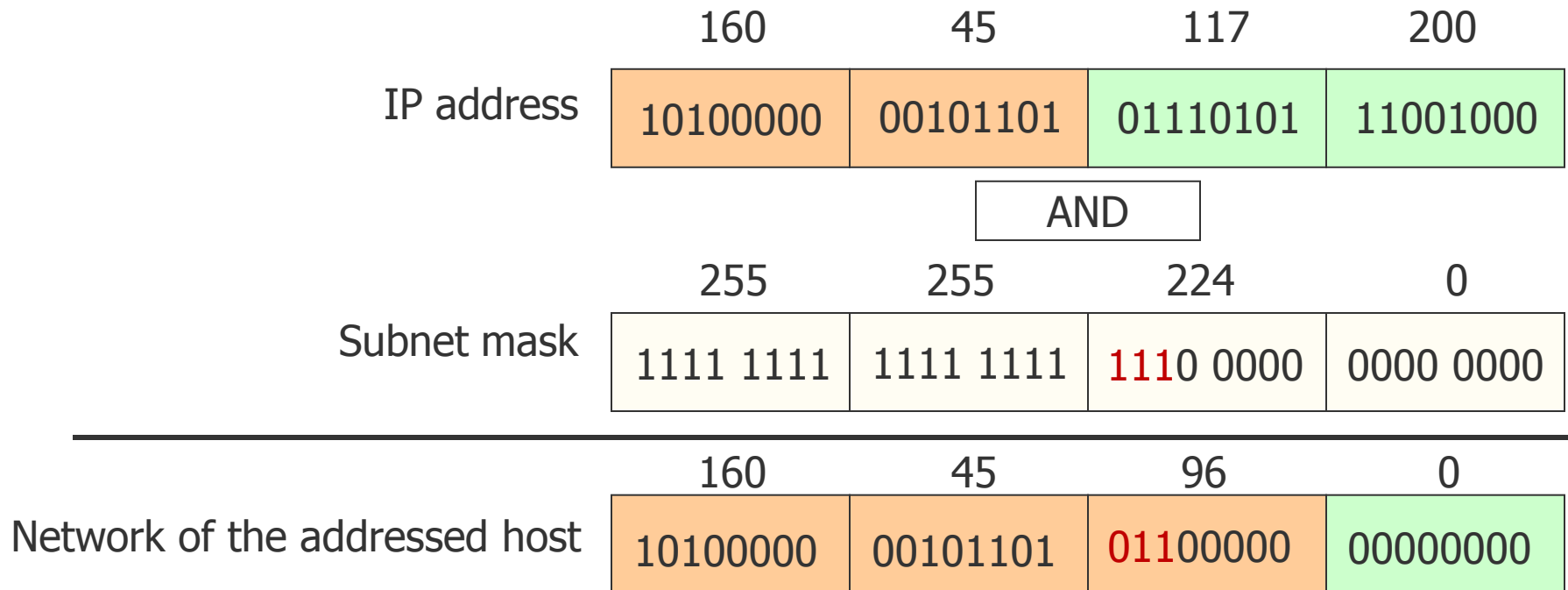

A router computes the subnet "160.45.96.0" and sends the packet to the router, which links this subnet.

Classless Inter-Domain Routing (CIDR)

- Problem:
 - Static categorization of IP addresses - how to use the very small class C networks efficiently?
- Remedy: Classless Inter-Domain Routing (CIDR)
 - Weakening of the rigid categorization by replacing the static classes by network prefixes of variable length
 - Form of an IP address: **a.b.c.d/n**
 - The **first n bits** are the **network identification**
 - The remaining (32 – n) bits are the **host identification**
 - Example: 147.250.3/17
 - The first 17 bits are network ID and the remaining 15 bits are host ID
- Used together with routing: Backbone router, e.g., on transatlantic links only considers the first n bits; thus small routing tables, little cost of routing decision

10010011.11111010.00000011.00000000

Network ID

Host ID



IPv6

The new IP: IPv6

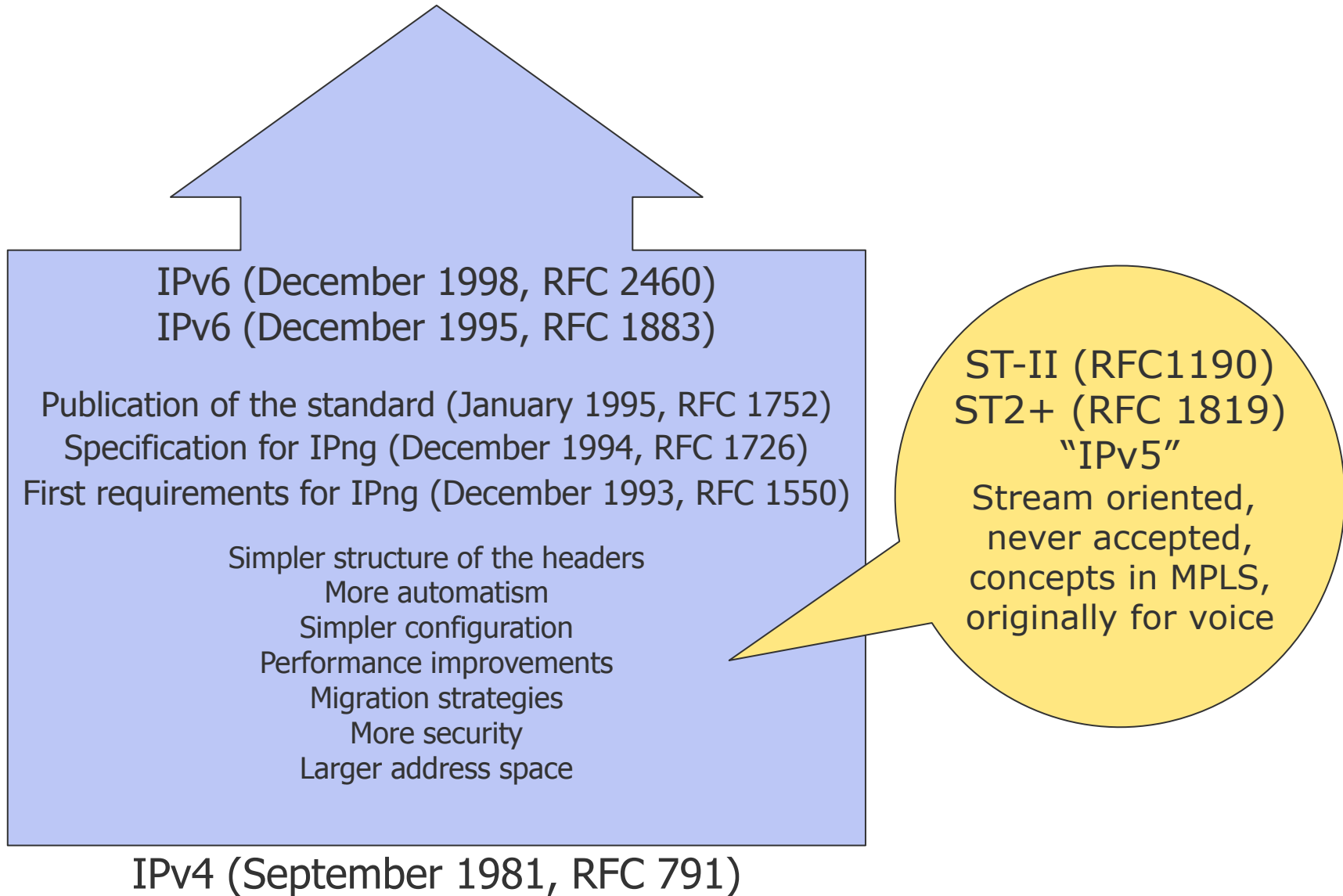

- Why changing the protocol, when IPv4 works well?
 - Dramatically increasing need for new IP addresses
 - Improved support of real time applications
 - Security mechanisms (Authentication and data protection)
 - Differentiation of types of service, in particular for real time applications
 - Support of mobility (hosts can go on journeys without address change)
 - Simplification of the protocol in order to ensure a faster processing
 - Reduction of the extent of the routing tables
 - Option for further development of the protocol

Changes from IPv4 to IPv6

- Changes fall into following categories (RFC 1883, RFC 2460)
 - Expanded Addressing Capabilities
 - Header Format Simplification
 - Improved Support for Extensions and Options
 - Flow Labeling Capability → Integrated Services
 - Authentication and Privacy Capabilities

IPv6: Characteristics

- Address size
 - 128-bit addresses (8 groups of each 4 hexadecimal numbers)
- Improved option mechanism
 - Simplifies and accelerates the processing of IPv6 packets in routers
- Auto-configuration of addresses
 - Dynamic allocation of IPv6-addresses
- Improvement of the address flexibility
 - Anycast address: Reach any one out of several
- Support of the reservation of resources
 - Marking of packets for special traffic
- Security mechanisms
 - Authentication and Privacy
- Simpler header structure:
 - IHL: redundant, no variable length of header by new option mechanism
 - Protocol, fragmentation fields: redundant, moved into the options
 - Checksum: Already done by layer 2 and 4

IPv6 Header

- **Version:** IP version number (4 bits)
- **Traffic Class:** classifying packets (8 bits)
- **Flow label:** virtual connection with certain characteristics/requirements (20 bits)
- **PayloadLen:** packet length after the 40-byte header (16 bits)
- **Next Header:** Indicates the type of the following extension header or the transport header (8 bits)
- **HopLimit:** At each node decremented by one. At zero the packet is discarded (8 bits)
- **Source Address:** The address of the original sender of the packet (128 bits)
- **Destination Address:** The address of the receiver (128 bits).
 - Not necessarily the final destination, if there is an optional routing header
- **Next Header/Data:** if an extension header is specified, it follows after the main header. Otherwise, the data are following

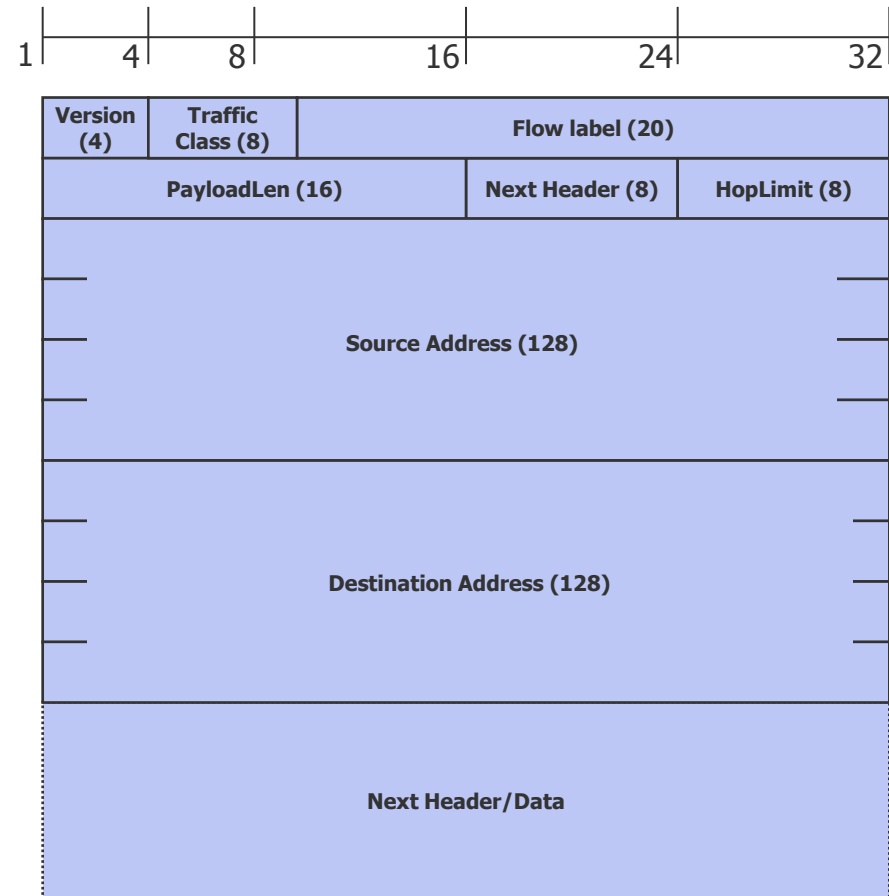

The prefix of an address characterizes geographical areas, providers, local internal areas,...

IPv6 Header

- Packet size requirements
 - IPv6 requires that every link has $MTU \geq 1280$ bytes
 - Links which cannot convey 1280 byte packets has to apply link-specific fragmentation and assembly at a layer **below** IPv6
 - Links that have a configurable MTU must be configured to have an MTU of at least 1280 bytes
 - It is recommended that they be configured with an $MTU \geq 1500$ bytes

IPv4 vs. IPv6: Header

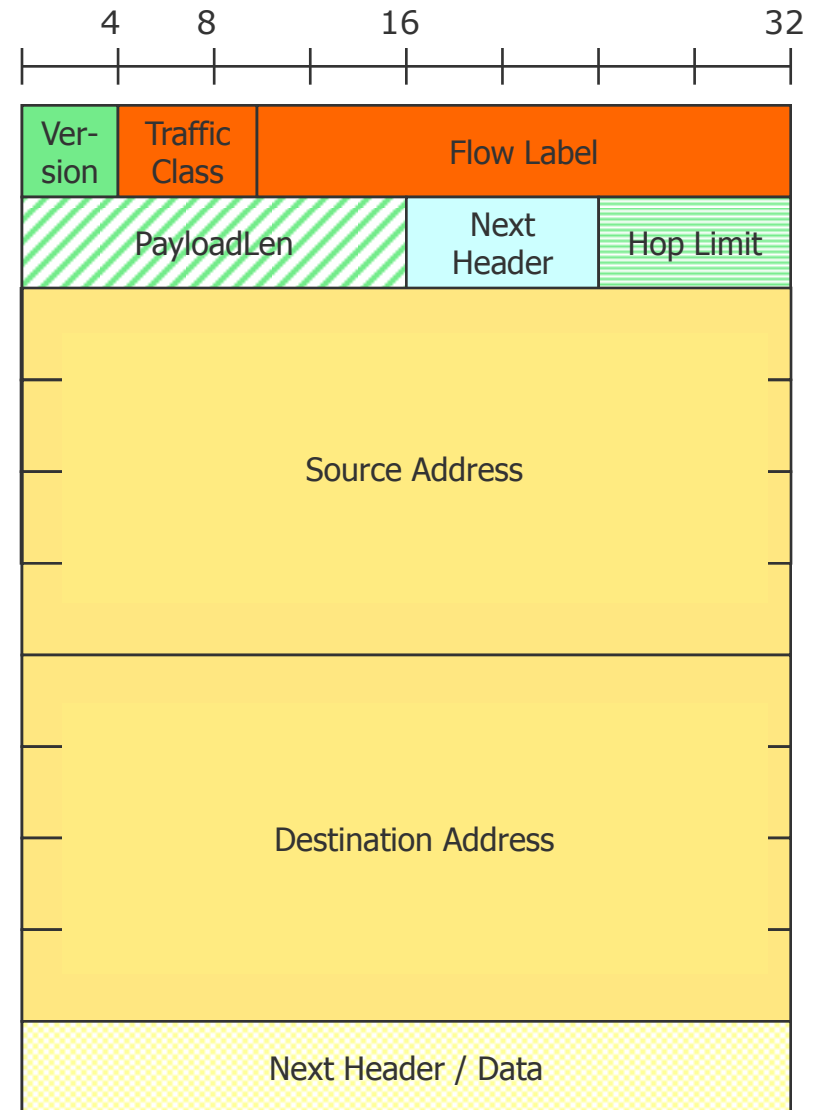
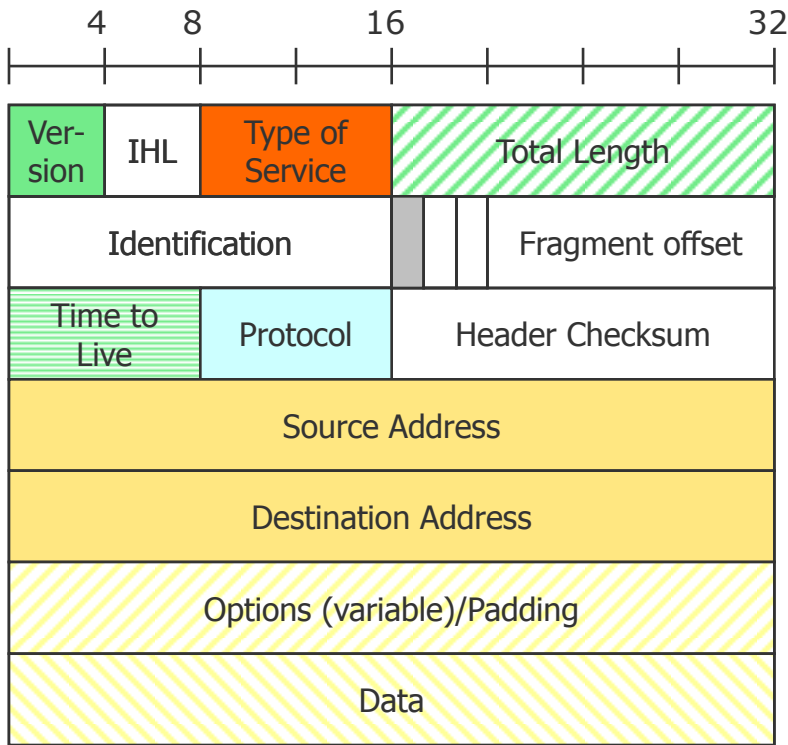

The IPv6 header is longer, but this is only caused by the longer addresses. Otherwise it is "better sorted" and thus faster to process by routers.

IPv6 Path MTU Discovery

- Path MTU Discovery
 - MTU: Maximum Transmission Unit
 - Maximum packet size in octets, that can be conveyed in one piece over a link
 - Path MTU: The minimum link MTU of all the links in a path between a source node and a destination node
- Path MTU Discovery Process
 - The originating node assumes the Path MTU is the MTU of the first hop in the path.
 - A trial packet of this size is sent out.
 - If any link is unable to handle it, an ICMPv6 Packet Too Big message is returned.
 - The originating node iteratively tries smaller packet sizes until it gets no complaints from any node, and then uses the largest MTU that was acceptable along the entire path.



IPv6

Extension Headers

IPv6 Extension Headers

- Optional data follows in extension headers. There are 6 headers defined:
 - Hop-by-Hop (information for single links)
All routers have to examine this field.
 - Momentarily only the support of Jumbograms (packets exceeding the normal IP packet length) is defined (length specification).
 - Routing (definition of a full or partly specified route)
 - Fragment (administration of fragments)
 - Difference to IPv4: Only the source can do fragmentation. Routers for which a packet is too large, only send an error message back to the source.
 - Authentication (of the sender)
 - Encapsulating security payload (information about the encrypted payload)
 - Destination options (additional information for the destination)
- Each extension should occur at most once!

IPv6 Extension Headers

- Examples for the use of extension headers:

IPv6 header	TCP header + data
Next Header = TCP	

IPv6 header	Routing header	TCP header + data
Next Header = Routing	Next Header = TCP	

IPv6 header	Routing header	Fragment header	TCP header + data
Next Header = Routing	Next Header = Fragment	Next Header = TCP	

IPv6 Extension Headers

- Two extension headers can carry a variable number of type-length-value (TLV) options
 - Hop-by-Hop
 - Destination options

- Options are encoded as:

Option Type	Opt Data Len	Option Data
-------------	--------------	-------------

- Option Type determines also the action that must be taken if the processing IPv6 node does not recognize the Option Type
 - The highest-order two bits specifies the action
 - 00: skip over this option and continue processing the header
 - 01: discard the packet
 - 10: discard the packet and ICMP message to source (unicast and multicast)
 - 11: discard the packet and ICMP message to source (only unicast)



IPv6

Addressing

IPv6 Addresses (RFC 4291)

- IPv6 Addresses are longer
 - 128 bit = 16 byte
 - 2^{128} addresses $\sim 3.4 \times 10^{38}$
- Three types of addresses
 - Unicast: An identifier for a single interface.
 - Anycast: An identifier for a set of interfaces. A packet sent to an anycast address is delivered to the “nearest” one.
 - Multicast: An identifier for a set of interfaces. A packet sent to a multicast address is delivered to all interfaces identified by that address.
- **There are no broadcast addresses in IPv6!**
 - Their function are superseded by multicast addresses

IPv6 Addresses: Representation of addresses

- The preferred form is

X:X:X:X:X:X:X:X

- the 'x's are the hexadecimal values of the eight 16-bit pieces of the address
 - Written as eight groups of four hexadecimal digits with colons as separators

- Examples:

8000:0000:0000:0000:0123:4567:89AB:CDEF

FEDC:BA98:7654:3210:FEDC:BA98:7654:3210

1080:0:0:0:8:800:200C:417A

IPv6 Addresses: Representation of addresses

- Some simplifications
 - Leading zeros within a group can be omitted: 0123 ➔ 123
 - Groups of 16 zero bits '0000' can be replaced by a pair of colons '::'
 - 8000:0000:0000:0000:0123:4567:89AB:CDEF ➔ 8000::123:4567:89AB:CDEF
 - The "::" can only appear once in an address

- Example:

The following addresses

2001:DB8:0:0:8:800:200C:417A

a unicast address

FF01:0:0:0:0:0:0:101

a multicast address

0:0:0:0:0:0:0:1

the loopback address

0:0:0:0:0:0:0:0

the unspecified addresses

may be represented as

2001:DB8::8:800:200C:417A

a unicast address

FF01::101

a multicast address

::1

the loopback address

::

the unspecified addresses

IPv6 Addresses: Representation of addresses

- Usage of IPv4 addresses together with IPv6 addresses as

x:x:x:x:x:x:d.d.d.d

- the 'x's are the hexadecimal values of the six high-order 16-bit pieces of the address, and the 'd's are the decimal values of the four low-order 8-bit pieces of the address (standard IPv4 representation)
- Examples:
 - 0:0:0:0:0:0:13.1.68.3
 - 0:0:0:0:0:FFFF:129.144.52.38
- or in compressed form:
 - ::13.1.68.3
 - ::FFFF:129.144.52.38

IPv6 Addresses: Representation of addresses

- The text representation of IPv6 address prefixes is similar to the way IPv4 address prefixes are written in Classless Inter-Domain Routing (CIDR)

ipv6-address/prefix-length

- ipv6-address: an IPv6 address
 - prefix-length: number of bits comprising the prefix (leftmost contiguous)
-
- Examples: 60-bit prefix 20010DB80000CD3 (hexadecimal)
 - 2001:0DB8:0000:CD30:0000:0000:0000:0000/60
 - 2001:0DB8::CD30:0:0:0:0/60
 - 2001:0DB8:0:CD30::/60
 - Combination of node address and a prefix:
 - node address 2001:0DB8:0:CD30:123:4567:89AB:CDEF
 - subnet number 2001:0DB8:0:CD30::/60
- Abbreviated to: 2001:0DB8:0:CD30:123:4567:89AB:CDEF/60**

IPv6 Addresses: Address Types

- The type of an IPv6 address is identified by the high-order bits of the address:

Address type	Binary prefix	IPv6 notation
Unspecified	00...0 (128 bits)	::/128
Loopback	00...1 (128 bits)	::1/128
Multicast	11111111	FF00::/8
Link-Local unicast	1111111010	FE80::/10
Global Unicast	(everything else)	

- Unspecified: It must never be assigned to any node. It indicates the absence of an address. Used when host initializes and does not have an address.
- Loopback: It may be used by a node to send an IPv6 packet to itself. It must not be assigned to any physical interface.

IPv6 Addresses: Address Types

- Global Unicast Addresses

- The general format for IPv6 Global Unicast addresses is as follows:

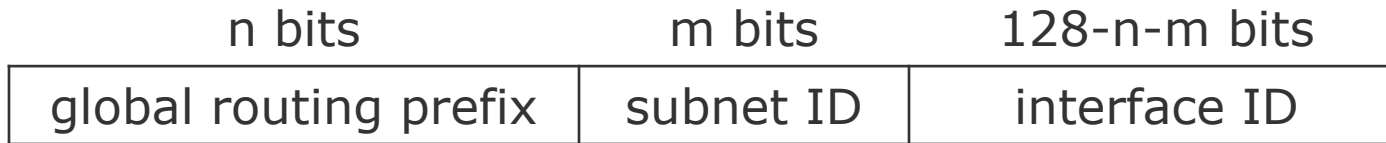

- global routing prefix: required for routing in a site
- subnet ID: identifier of a link within the site

IPv6 Addresses: Address Types

- Anycast Addresses
 - Anycast addresses are allocated from the unicast address space
 - Anycast addresses are syntactically indistinguishable from unicast addresses
 - When a unicast address is assigned to more than one interface, thus it becomes an anycast address
- Usage scenarios:
 - Identification of the set of routers belonging to an organization providing Internet service
 - Identification of the set of routers attached to a particular subnet
 - Identification of the set of routers providing entry into a particular routing domain
- Format:

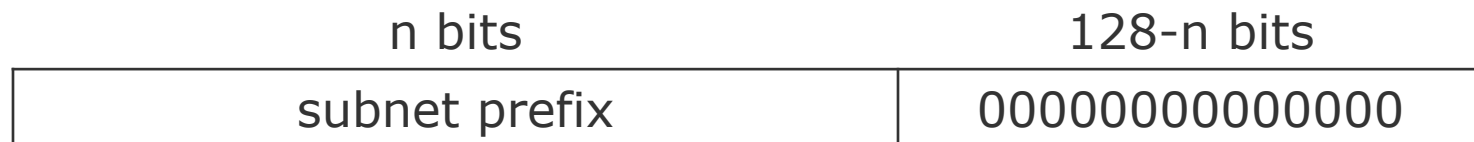

IPv6 Addresses: Address Types

- Multicast Addresses:

- An IPv6 multicast address is an identifier for a group of interfaces
- An interface may belong to any number of multicast groups.

- Format:



- 11111111: identification of multicast addresses
- flgs: set of 4 flags: ORPT
 - T=0: permanently assigned multicast address
 - T=1: non-permanently assigned multicast address (dynamically, on-demand)
 - P: multicast address assignment based on network prefix (RFC 3306)
 - R: embedding of the rendezvous point (RFC 3956)
- scop: limit the scope of the multicast group

Scope values (4 bit)	
0	reserved
1	Interface-Local scope
2	Link-Local scope
3	reserved
4	Admin-Local scope
5	Site-Local scope
6	(unassigned)
7	(unassigned)
8	Organization-Local scope
9	(unassigned)
A	(unassigned)
B	(unassigned)
C	(unassigned)
D	(unassigned)
E	Global scope
F	reserved

IPv6

Transition from IPv4 to IPv6

Transition from IPv4 to IPv6

- IPv6 cannot be introduced “over night”... for some time both IP variants will be used in parallel.
 - Nearly all operating systems support both IP variants
 - Only the infrastructure nodes has to be updated
 - But: how to enable two modern IPv6-based hosts to communicate if only an IPv4-based network is in between?

➔ Transition methods

- Several transitions methods proposed
 - Co-existence of IPv4 and IPv6
 - Translation
 - Tunneling

Transition from IPv4 to IPv6

- Co-existence of IPv4 and IPv6
 - Co-existence involves all client and server nodes supporting both IPv4 and IPv6
 - Running essentially two complete networks that share the same infrastructure
- Dual Stack

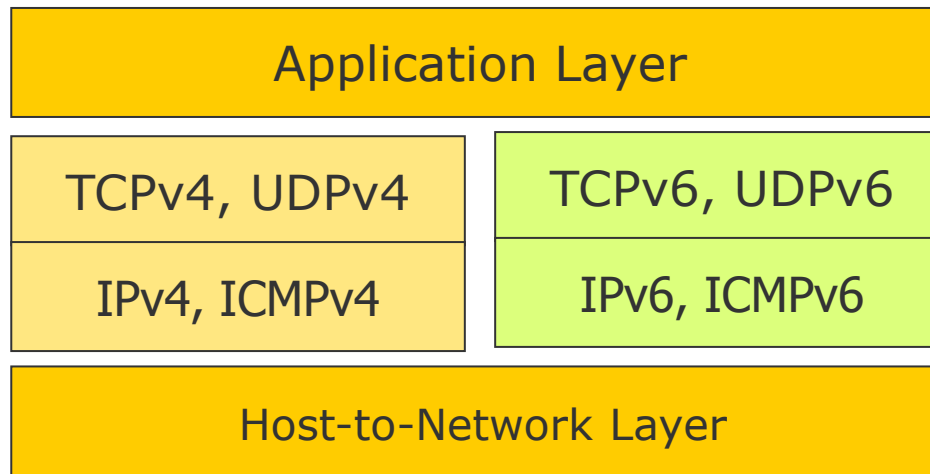

Transition from IPv4 to IPv6

- Translation or Header Conversion
 - Router translates an incoming IPv6 packet into a IPv4 packet, receiving router retranslates
 - Problem: Header fields are not compatible!

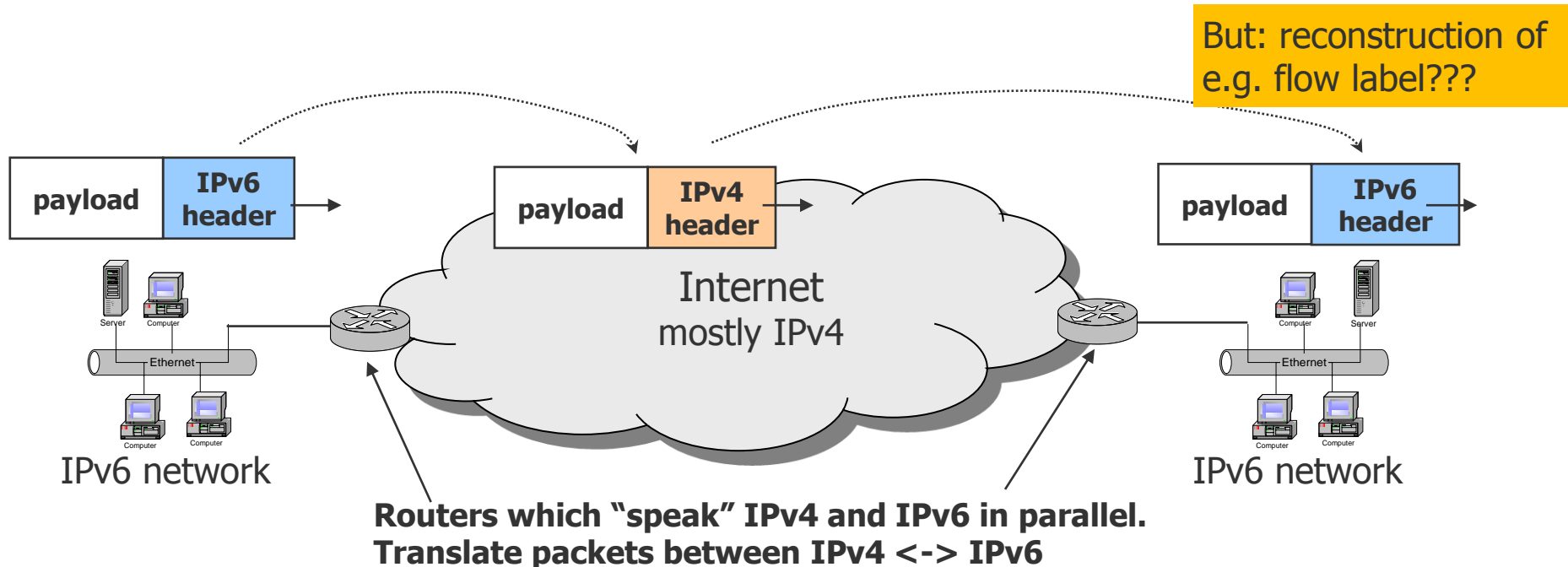

Transition from IPv4 to IPv6

● Tunneling

- Router at the entry to the IPv4-based network encapsulates an incoming IPv6 packet into a new IPv4 packet with destination address of the next router also supporting IPv6

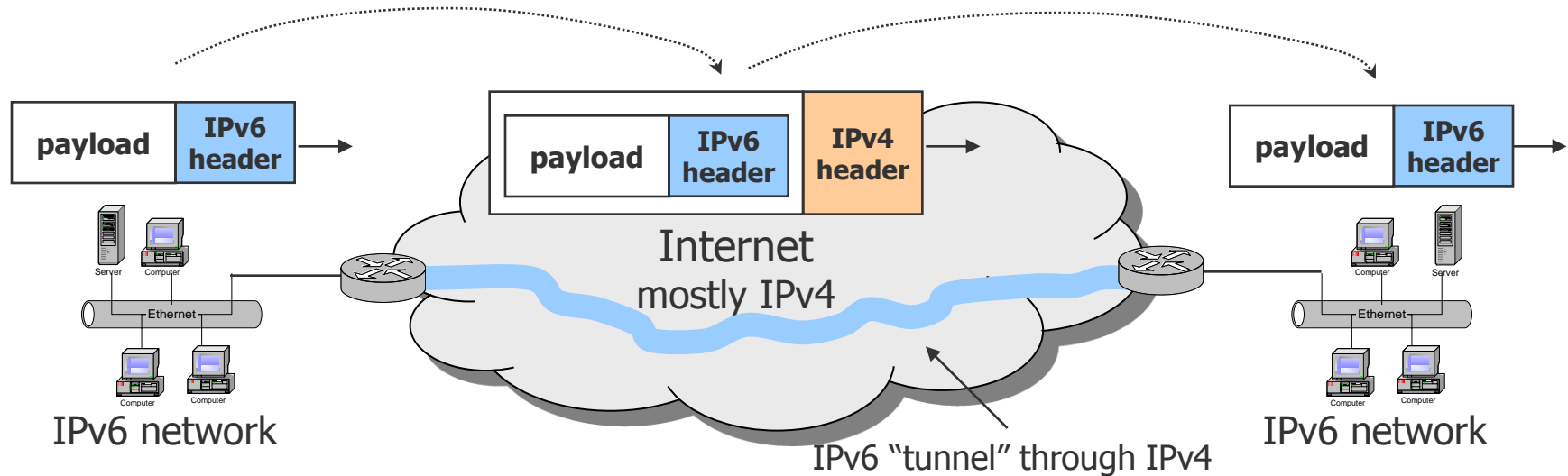

- More overhead because of two headers for one packet, but no information loss
- **Tunneling** is a general concept also used for multicast, VPN, etc: it simply means "pack a whole packet as it is into a new packet of different protocol"

Network Address Translation (NAT)

Network Address Translation (NAT)

- Problem: IP addresses are scarce, thus not every node gets an public IP address
- Approach: Special IP addresses that must not be used in the global public Internet, but can be used in an **Intranet**
- Each internal computer in the Intranet needs an own IP address to communicate with the others.
- For this purpose, "**private**" address blocks are reserved
 - 10.0.0.0 – 10.255.255.255
 - 172.16.0.0 – 172.31.255.255
 - 192.168.0.0 – 192.168.255.255
- When using addresses of those ranges, the internal computers can communicate with each other

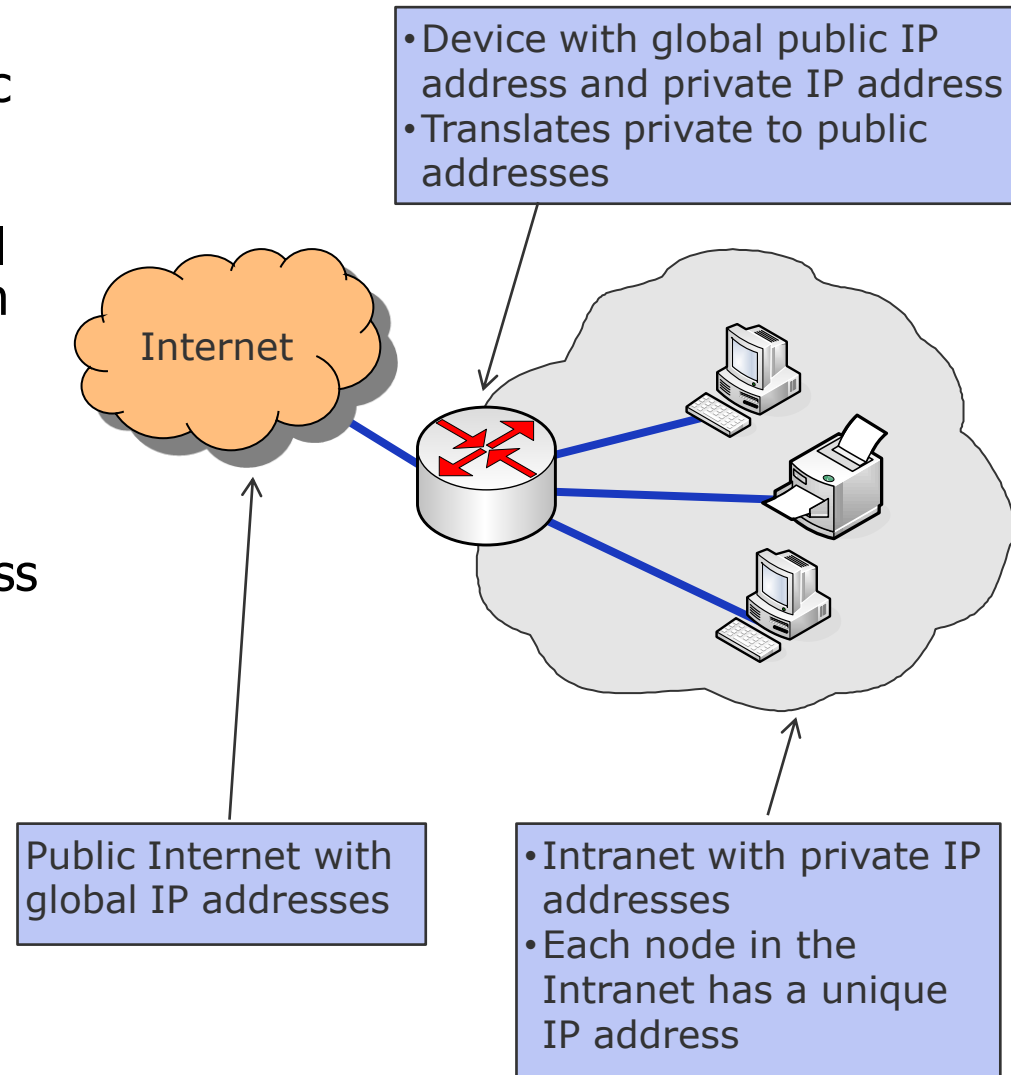

Network Address Translation (NAT)

- Packets with private IP addresses are not forwarded by a router
- Thus: routers, which are attached to the “**external world**” need a **global address**
- Assign a few IP addresses to a company which are known by a “**NAT box**” which usually is installed with the router
- When data are leaving the own network, an address translation takes place: the NAT box exchanges the private address with a globally valid one
- Side effect: hiding of the internal network structure (security)

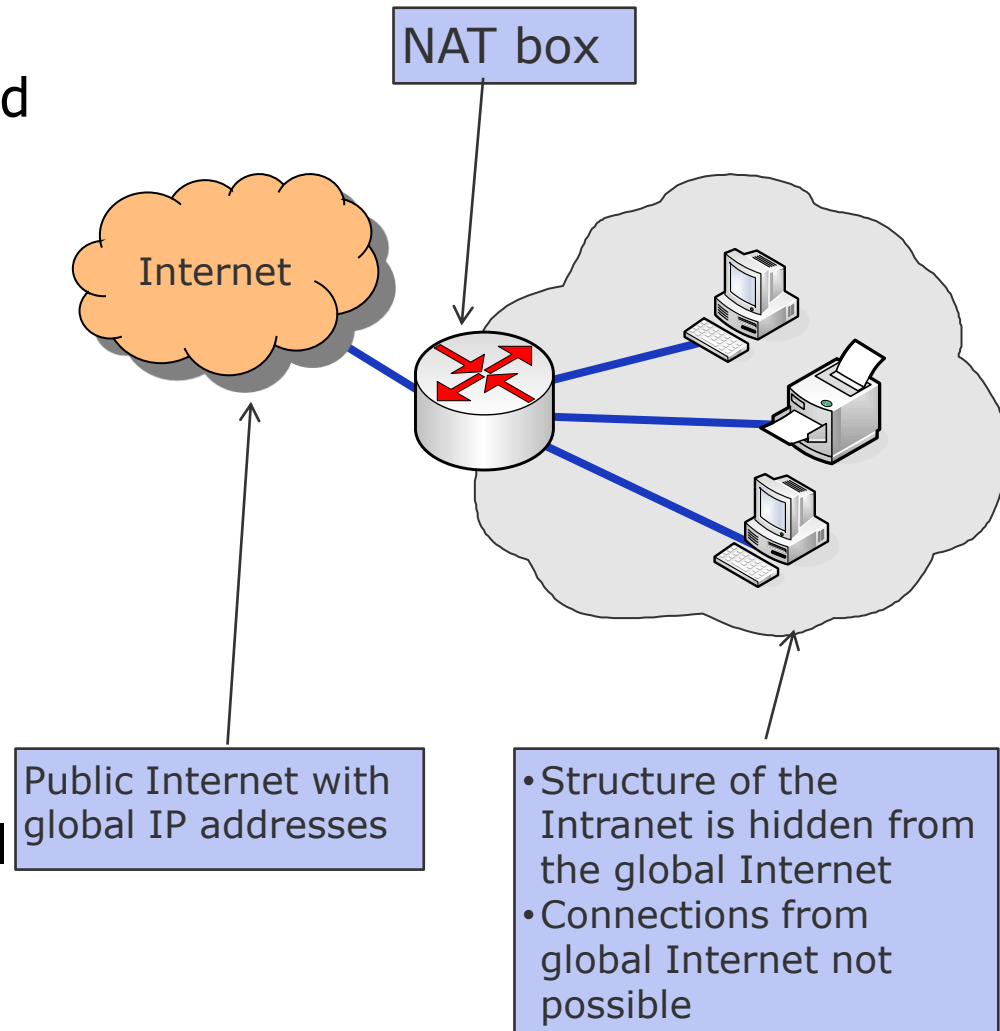

NAT Variants

- NAT is available in several “variants”, known under different names
- Basic NAT (also: Static NAT)
 - Each private IP address is translated into one certain external IP address
 - Either, you need as much external addresses as private ones, otherwise no re-translation is possible when a reply arrives
 - Or, you manage a pool of external IP addresses and assign one dynamically when a request is sent out

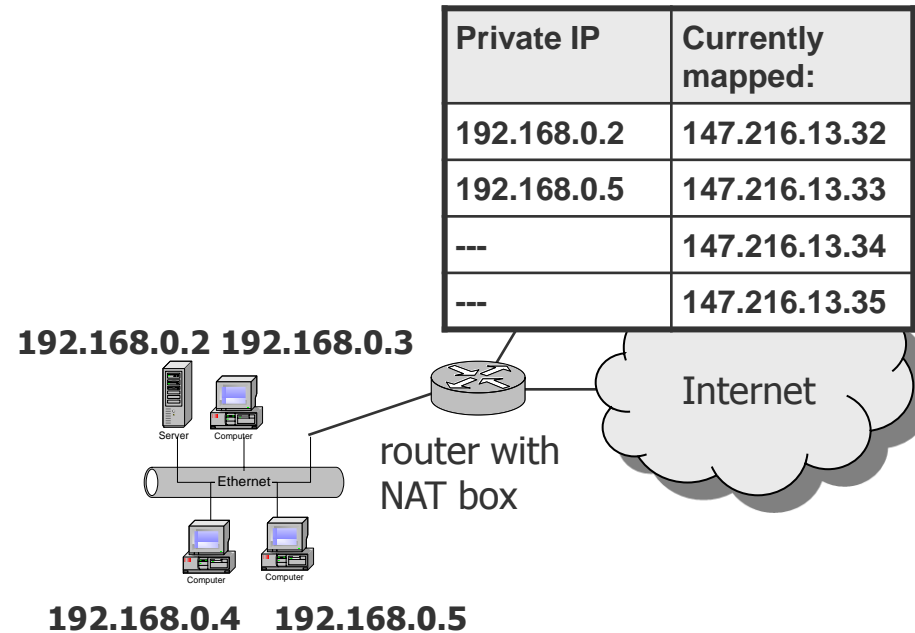
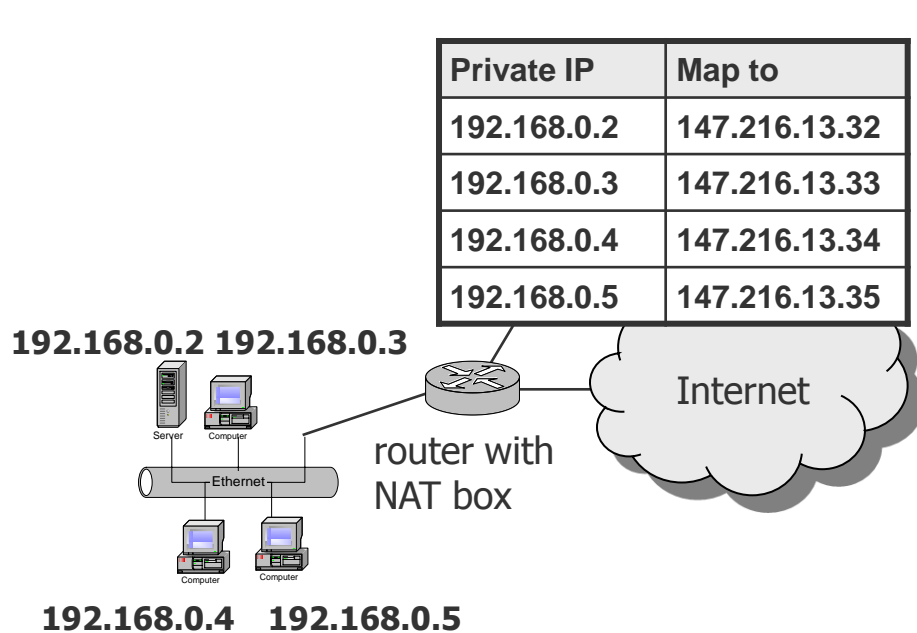

NAT Variants

- Disadvantages of static NAT:
 - With static mapping, you need as much public IP addresses as you have computers
 - With dynamic mapping, you need less public IP addresses, but for times of high traffic you nevertheless need nearly as much addresses as local computers
 - Those approaches help to hide the network structure, but not to save addresses
- Hiding NAT (also: NAPT: Network Address Port Translation, Masquerading)
 - Translates several local addresses into the same external address
 - Now: some more details are necessary to deliver a response

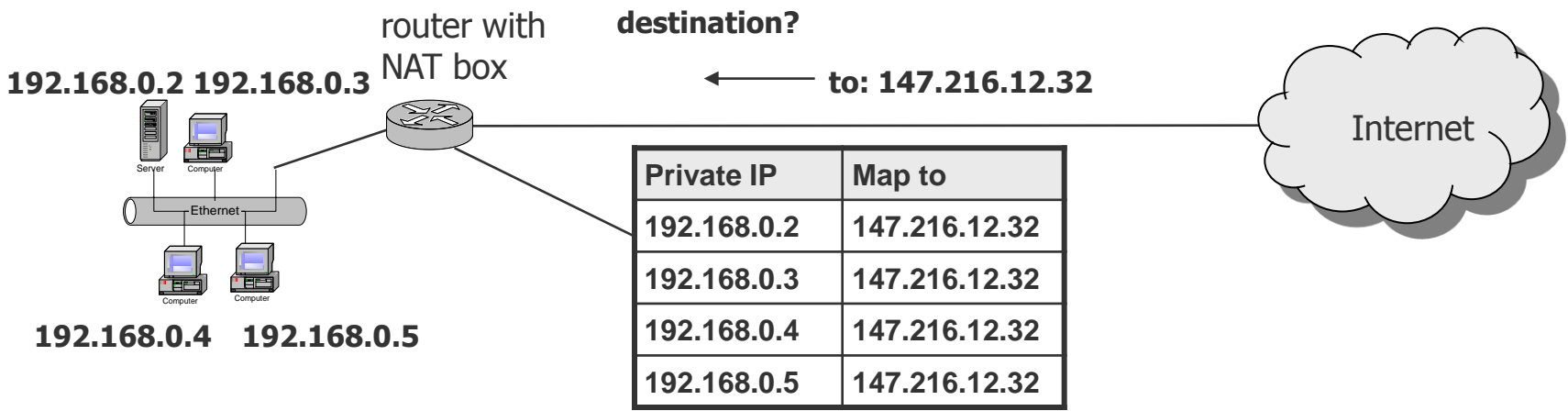

Network Address Port Translation (NAPT)

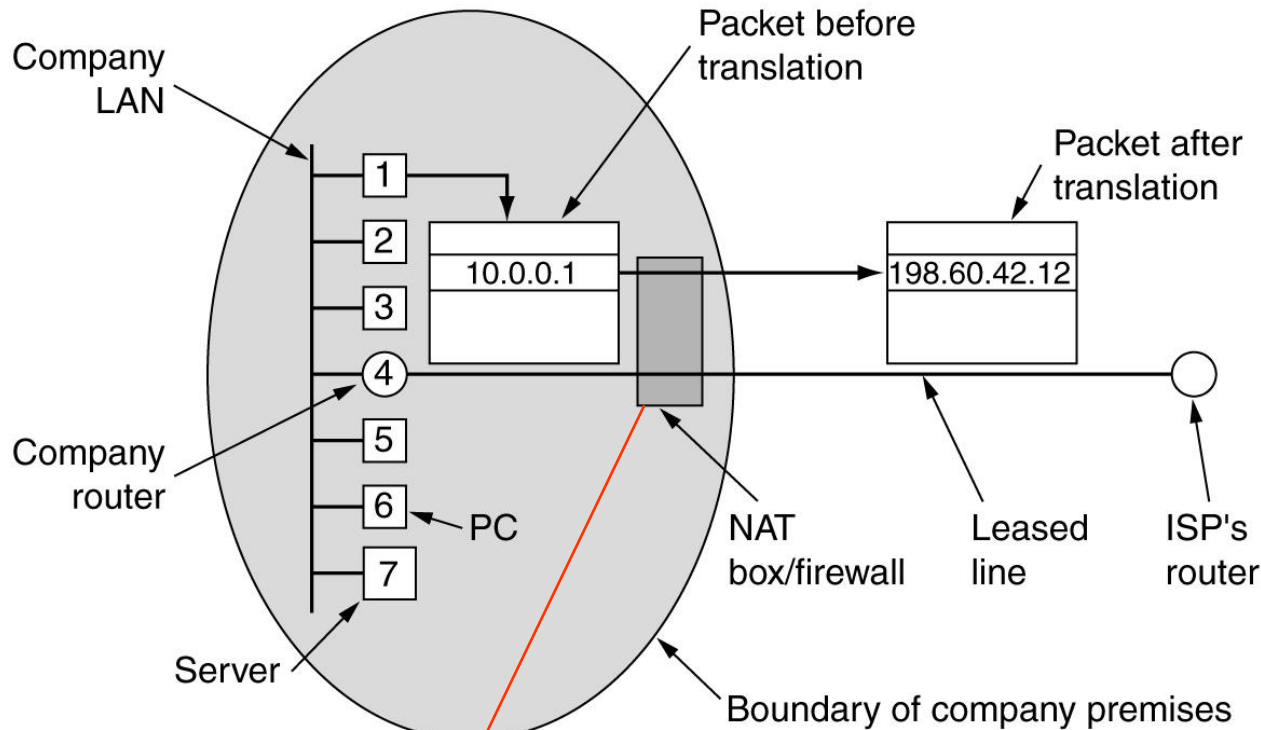

Protocol	Port (local)	IP (local)	Port (global)	IP (global)	IP (destination)	Port (destination)
TCP	1066	10.0.0.1	1066	198.60.42.12	147.216.12.221	21
TCP	1500	10.0.0.7	1500	198.60.42.12	207.17.4.21	80

Problems with NAT

- NAT works well with communication initiated from the Intranet.
- But: how could someone from outside give a request to the Intranet (e.g. to the web server)?
 - NAT box needs to be a bit more “intelligent”
 - Some static information has to be stored, e.g., “each incoming request with port 80 has to be mapped to the private address of the web server”
 - Still problems with applications like ICQ
 - Thus, only more IP addresses really help to solve the problem

Even more NAT versions...

- Carrier Grade NAT (CGN)
 - Also known as LSN (Large Scale NAT)
 - Use a NAT box for a larger number of customers, e.g., a street, a suburb to further mitigate IPv4 address exhaustion
 - Again – breaks end-to-end principle, difficult to use well-known ports etc.
- NAT64 (RFC 6146)
 - Mechanism to connect IPv6 hosts to IPv4 servers
 - IPv6 client embeds IPv4 address (RFC 6052)
 - NAT maps IPv6 to IPv4

Auxiliary Protocols

ARP, RARP, DHCP, ICMP

Internet Layer

- Raw division into three tasks:
 - Data transfer over a global network
 - Route decision at the sub-nodes
 - Control of the network or transmission status

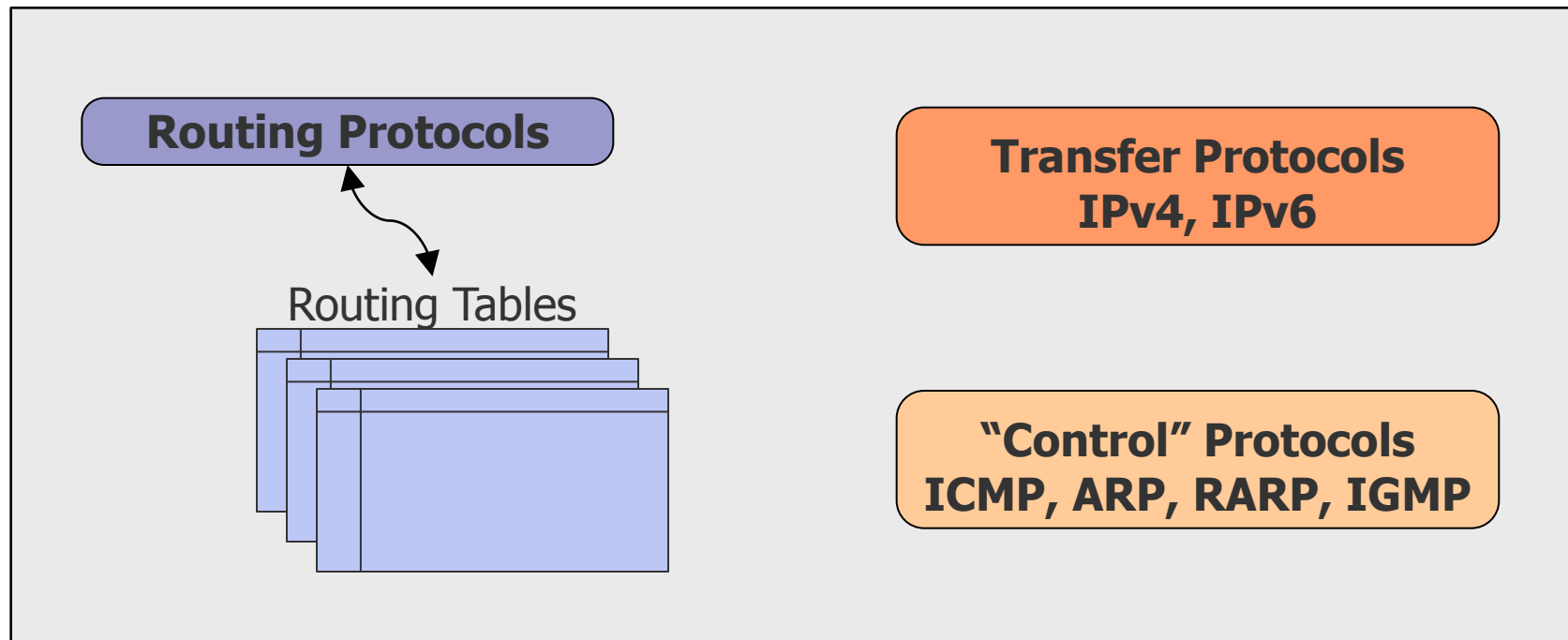

Auxiliary Protocols

- IP serves only for sending packets with well-known addresses. Some questions however remain open, which are handled by auxiliary protocols:
 - Address Resolution Protocol (ARP)
 - Reverse Address Resolution Protocol (RARP)
 - Internet Control Message Protocol (ICMP)
 - Internet Group Management Protocol (IGMP)

Delivery of Packets

AL
TL
NL
DL
PL

IP Addresses

MAC Addresses

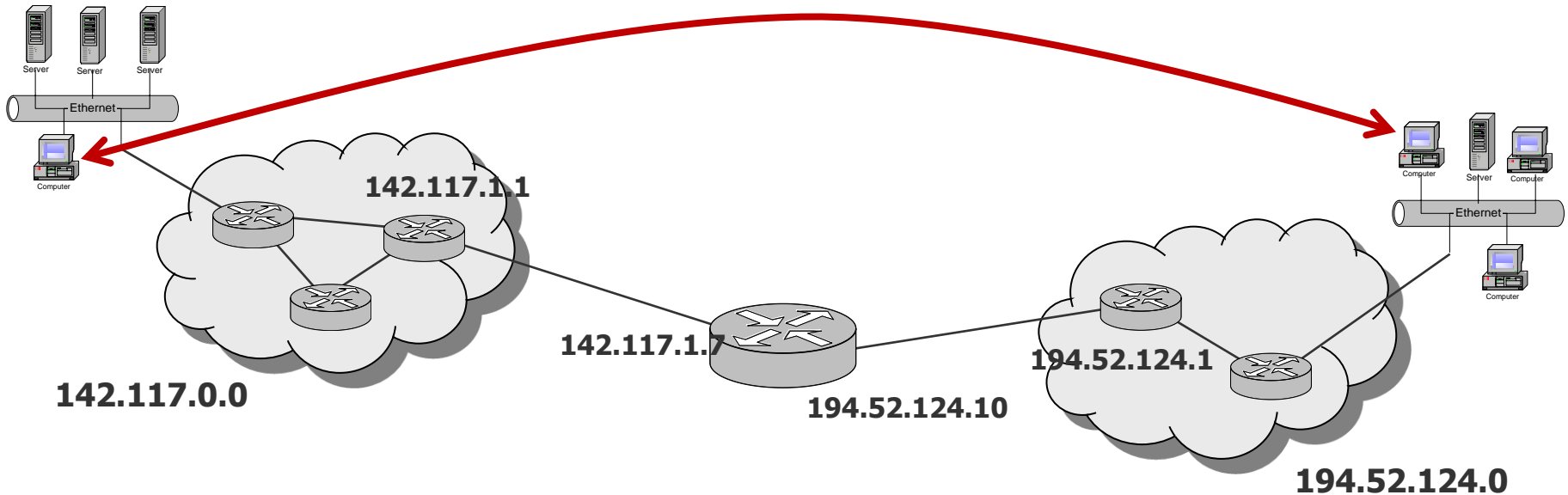

Delivery of IP Packets

- Address Resolution Protocol (ARP)
 - The Internet is a virtual network, which is build upon physical networks.
 - **IP addresses** only offer a **logical address space**
 - The hardware on the lower layers do not understand IP addresses
 - Within a **local area network**, the sender must know the **hardware address** (MAC address) of the receiver before sending an IP packet to the destination host
 - The hardware address is with **Ethernet an 48-bit address**, which is assigned to a **network interface card** (NIC) by the manufacturer
 - With ARP, IP is mapped to the hardware address and vice versa
 - ARP uses the **local broadcast address** to dynamically inquire for the hardware address by indication of the searched IP address
 - An ARP request is only **valid** in the **local network**

Address Resolution Protocol (ARP)

ARP Request

Look for the physical address to the IP address 192.168.13.20

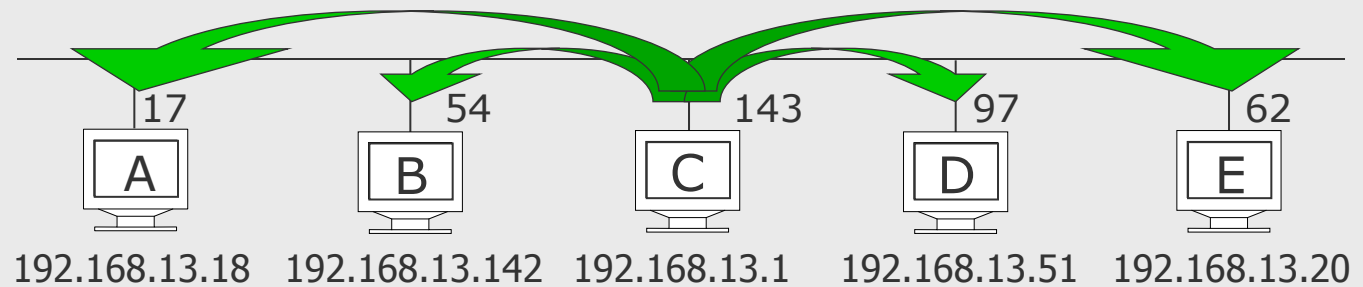

ARP Response

The physical address to the IP address 192.168.13.20 is 62

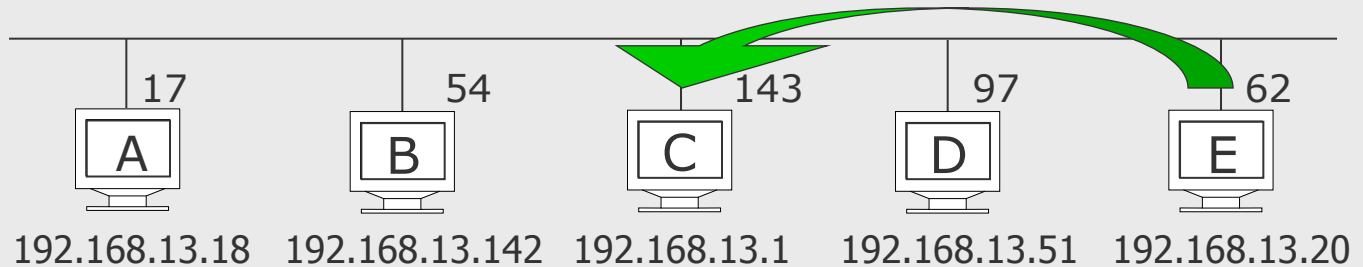

- The host with the inquired IP address sends a response
- Each host stores familiar IP and MAC addresses in a table
- The entries become invalid after a certain time to avoid mistakes e.g. with the exchange of a network interface card

Address Resolution Protocol (ARP)

Optimization of the procedure:

Each computer occasionally sends an ARP request (broadcast) to its own IP address.

ARP Request

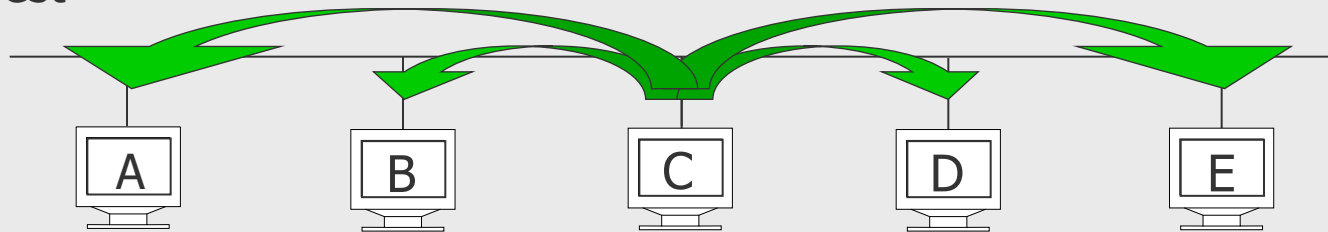

Each receiving host stores the sender IP and sender hardware address in its ARP Cache

Reverse Address Resolution Protocol (RARP)

- Not with all operating systems an IP address is assigned to a computer during startup. How does such a computer receive its IP address after booting?
- With the help of Reverse ARP, well-known hardware addresses are assigned to IP-addresses.
- RARP makes it possible that a booted machine broadcasts its hardware address and gets back by a RARP server the appropriate IP address.

RARP Request

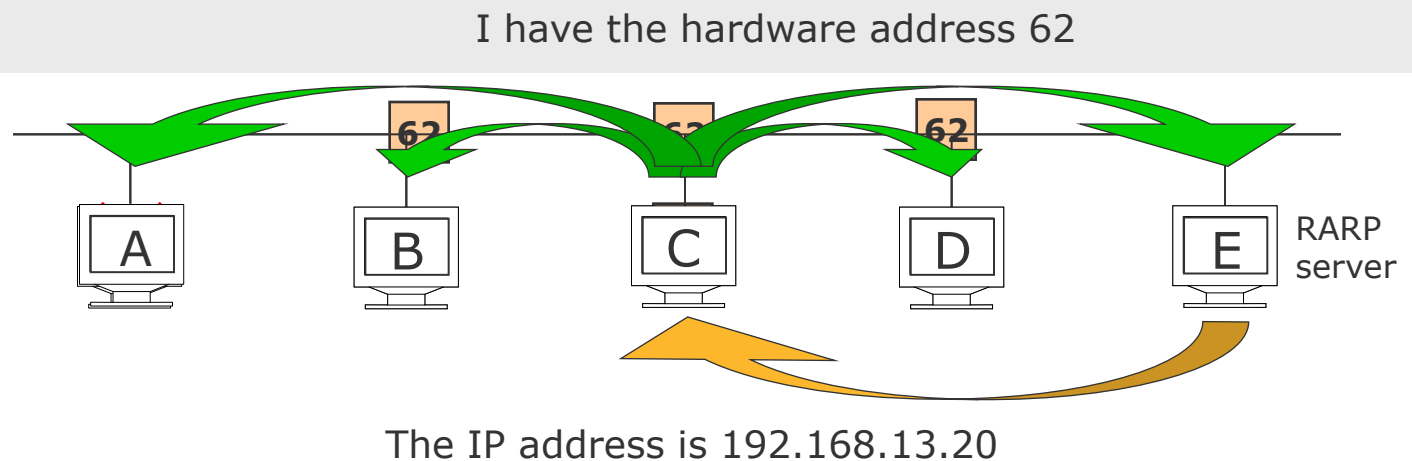

Dynamic Host Configuration Protocol (DHCP)

Dynamic Host Configuration Protocol (DHCP)

- Problem with RARP: RARP requests are not passed on by routers, therefore an own RARP server must be set up in each local network.
- Solution: **DHCP**. A computer sends a DHCP DISCOVER packet. In each subnet a DHCP Relay Agent is placed, who passes such a message on to the DHCP server.

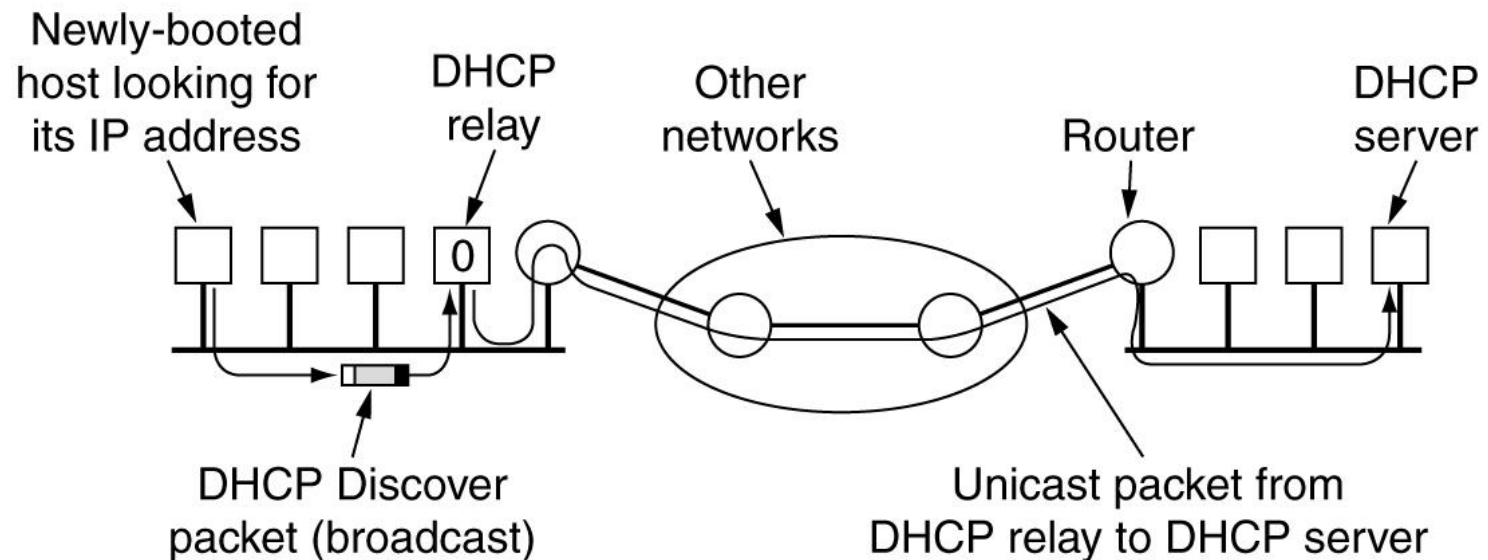

- Additionally to the IP address also the subnet mask, domain names, ... are transferred. Thus, DHCP can be used for full host configuration.

Dynamic Host Configuration Protocol (DHCP)

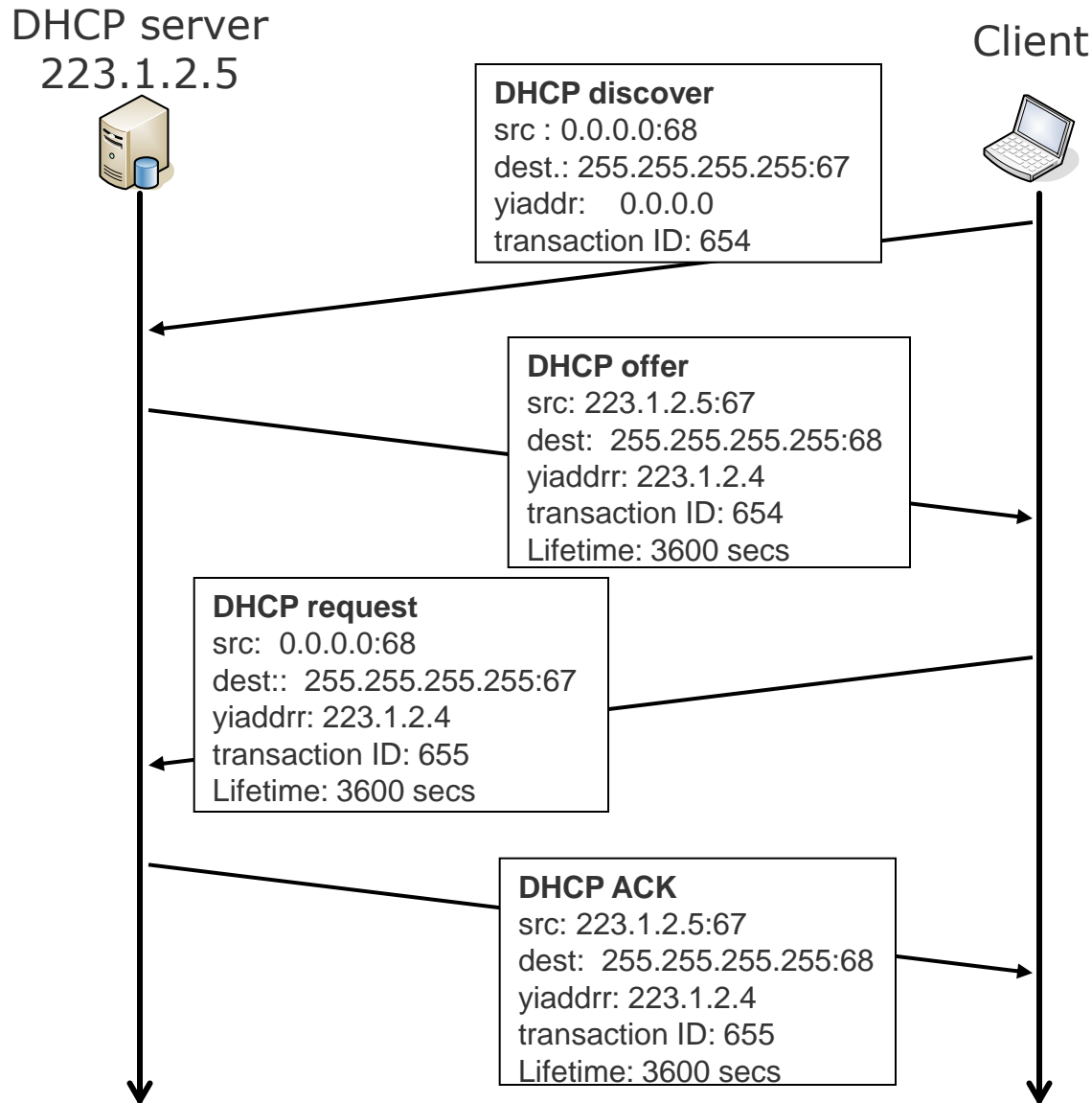

Internet Group Management Protocol (IGMP)

How to realize Multicast with IPv4?

Unicast

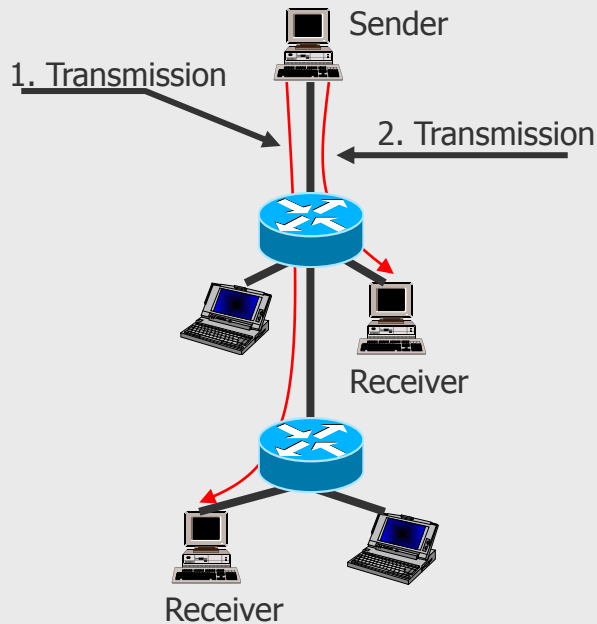

Unicast is an end-to-end transmission between two hosts.

- Multiple transmissions have to be executed sequentially.
- For multicast, data is replicated by the network and sent in parallel.
- Inefficient use of time and capacities.

Problem with Unicast and Broadcast:
How can a group of computers be addressed efficiently?

Broadcast

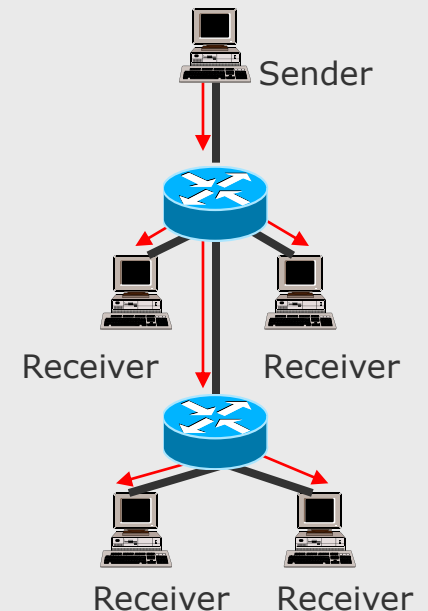

Broadcast is a one-to-all transmission

- A packet is sent to all possible receivers , many of them may not need it
- Network load by use of transmission paths, which are not needed actually

IP Multicast

How can a limited group of computers be addressed with something between unicast and broadcast?

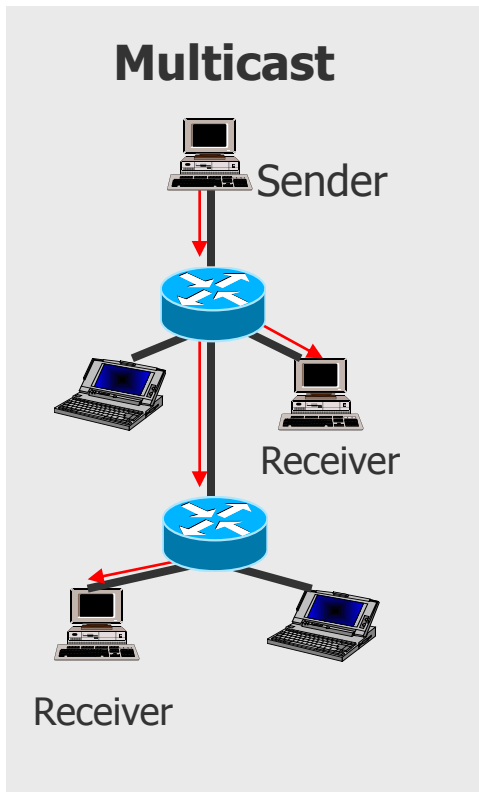

Transmission to $n > 1$ selected stations: **Multicast**

Problems:

- Support of multicast is not compulsory required to be supported by all devices in IPv4, mandatory in IPv6
- Efficient addressing: how to arrange to reach exactly the desired devices?

IPv4:

- Use of multicast addresses: Class D addresses, from 224.0.0.0 to 239.255.255.255
- Some of them are reserved for certain purposes (e.g. 224.0.0.2 - all gateways in the subnet)
- Standard IP functionality is enhanced by functions of the **Internet Group Management Protocol (IGMP)** for IPv4 and **Multicast Listener Discovery (MLD)** for IPv6

Internet Group Management Protocol (IGMP)

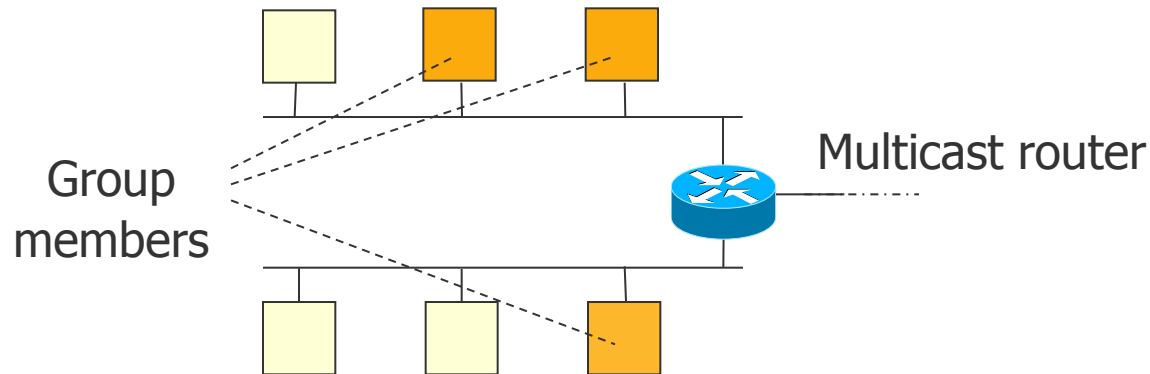

- For delivery of multicast messages to all group members that are located in different physical networks, routers need information about group associations.
- If groups are only temporary, routers have to acquire information about associated hosts by themselves.
- By means of IGMP messages (encapsulated into IP packets), a router informs all hosts in its subnet to which groups they belong
- Routers notice the existence of group members
- Periodically, the routers ask (Polling), which groups of multicast are still present
- Routers exchange information to build multicast routing trees

Multicast Control Path – an example

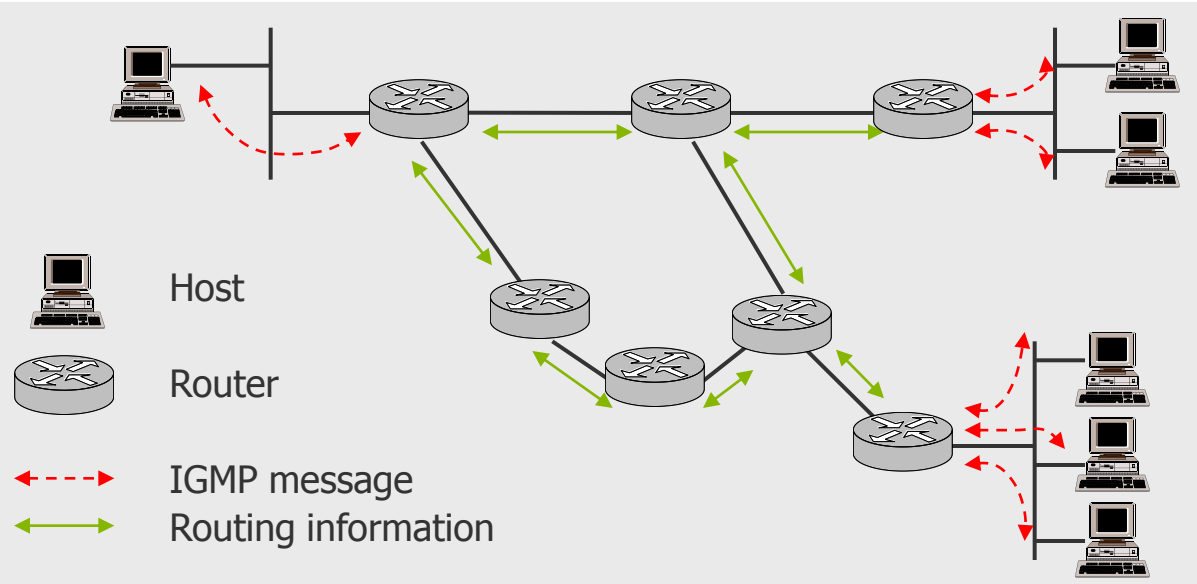

- The routers exchange their routing information
- By means of IGMP messages, group associations are being passed on
- To each multicast address the routers administrate routing information

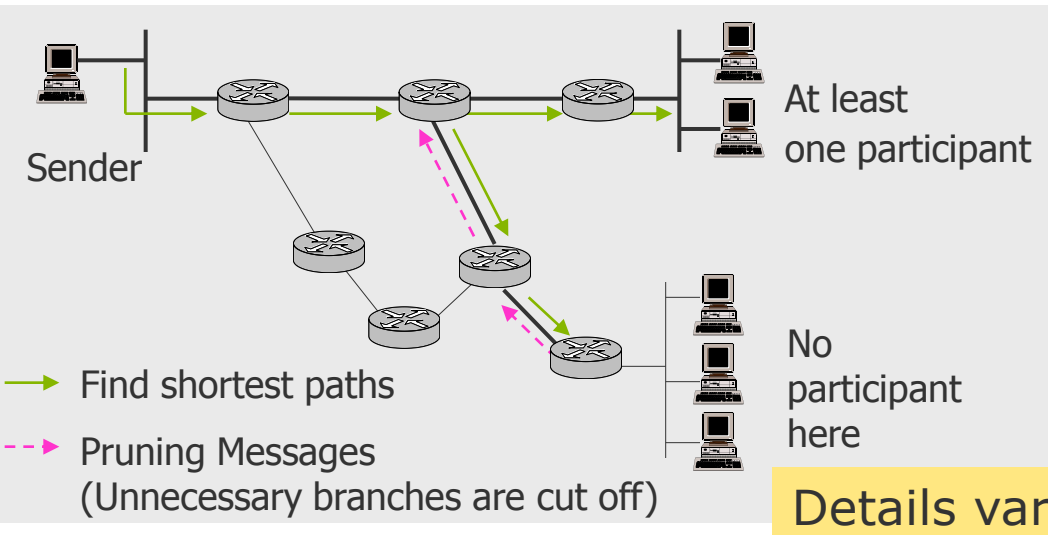

- The routing protocol computes the shortest paths to all computers in the network
- Routers, which do not have participants in their network, can send back Pruning Messages; next time no more multicast packets are sent to this routers

Details vary by the specific protocol used!

Multicast Groups: Example

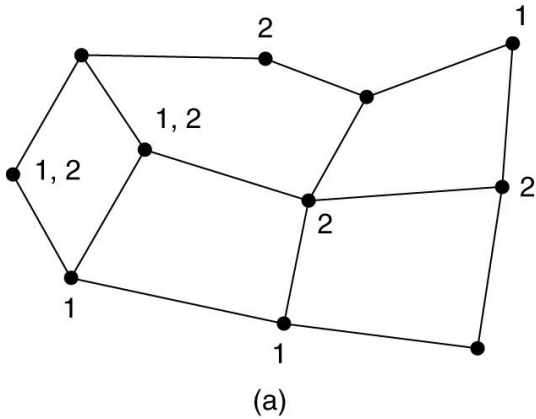

Network with interest into two multicast groups

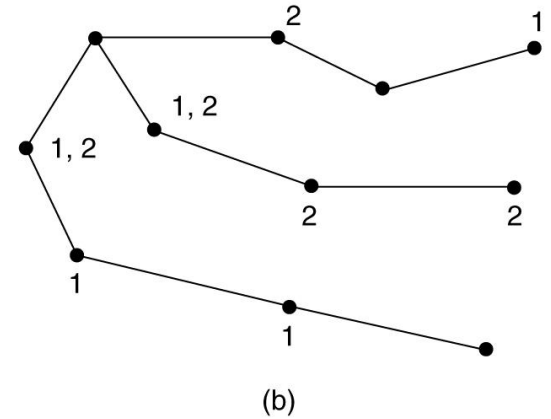

Sink Tree for the left router

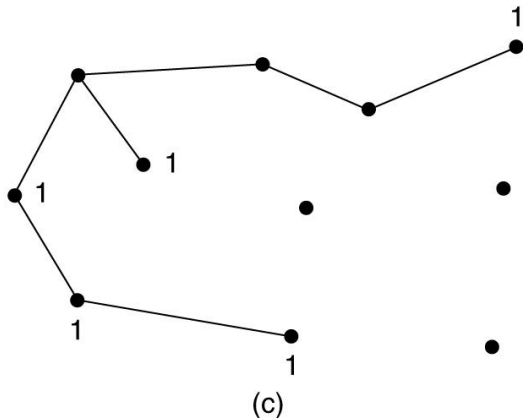

Multicast routing tree for group 1

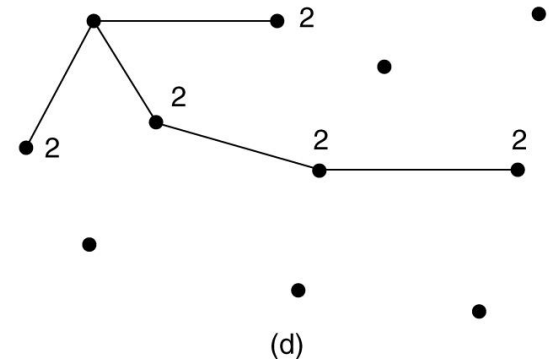

Multicast routing tree for group 2

Multicast Routing – PIM-SM as example

- Protocol Independent Multicast – Sparse Mode (RFC 2362)
 - Can support Internet-wide MC groups, does not require specific unicast protocol
 - No flooding plus pruning but explicit construction of a tree
- Assumptions
 - Only a very low percentage of nodes will subscribe to a MC group
- Joining an MC group
 - IGMP join in the local subnet
 - PIM join to a so-called rendezvous point (RP)
 - PIM join between RP and sender
 - Routers forward join messages to an RP
- MC sender
 - Send register messages to RP
 - RP distributes data along MC tree

Internet Control Message Protocol (ICMP)

Internet Control Message Protocol (ICMP)

- ICMP is a control protocol of layer 3, which is build upon IP! This protocol is used e.g. by routers, if something unexpected happens, like TTL=0.
- Example 1: if a router cannot forward a packet, the source can be informed about it. ICMP messages are in particular helpful in the case of failures in the network.
- Example 2: ping (question about a life sign of a station) uses ICMP messages.

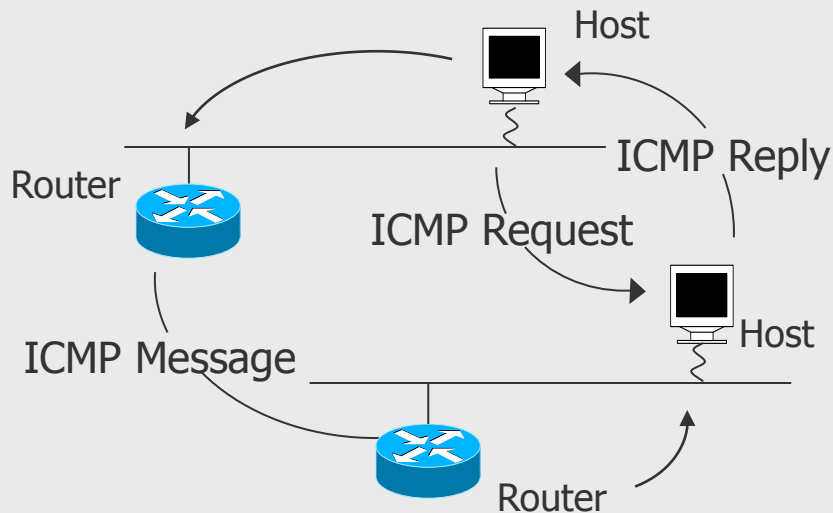

ICMP Request: status request

ICMP Reply: status reply

ICMP Message: Transmission of status information and control messages

ICMP: Header

- ICMP message fields
 - Type: purpose of the ICMP message
 - Around 40 defined ICMP message types
 - Types 41 – 255 for future use
 - Code: additional information about the condition
 - Very rarely used
 - Checksum: same type of checksum as used for IP
- Message categories
 - Error messages: to report an event. These messages do not have a response.
 - Error messages include the IP header that generated the error!
 - Queries: To get some information from a node. These messages have a matching response.

1 byte	1 byte	2 byte
Type	Code	Checksum
ICMP Data (content and format depends on Type)		

General format of ICMP messages

1 byte	1 byte	2 byte
Type = 3	Code	Checksum
Unused (all 0 bits)		
IP Header (20 bytes) and First 8 bytes of original packet data		

Format of Destination Unreachable ICMP message

ICMP: Header

- ICMP transmits error and control messages on the network level. These messages are sent in an IP packet
- Type/code indicates the type (and format) of the message, e.g.:

Type	Meaning
0	Destination unreachable (packet cannot be sent)
3	Echo request/reply (status request, e.g. for ping)
4	Source Quench (Choke packet, data rate reduction)
11	Time exceeded for datagram (TTL = 0, the packet is discarded)
12	Parameter problem on datagram (A header field is set wrongly)
15/16	Information Request/Reply
30	Trace route (Trace the network path)

ICMP: Applications

- Some very popular applications of ICMP
 - Ping
 - Traceroute
 - Path MTU

ICMP & IPv6

- ICMPv6 introduces some changes to ICMP
 - New ICMPv6 messages and procedures replace ARP
 - There are ICMPv6 messages to help with automatic address configuration
 - Path MTU discovery is automatic
 - New PacketTooBig message is sent to the source, since IPv6 routers do not fragment
 - There is no Source Quench in ICMPv6
 - IGMP for multicast is included in ICMPv6 (Multicast Listener Discovery, RFC4604)
 - ICMPv6 helps detect nonfunctioning routers and inactive partner hosts

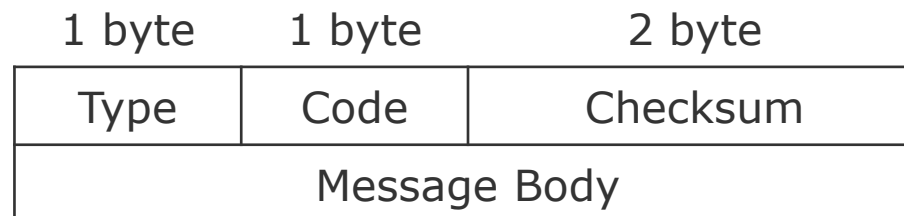

General format of ICMPv6 messages



Some Tools

Some Tools: Arp

- Arp
 - Display and insert entries into the arp cache

```
x:\W>arp -a
```

```
Interface: 160.45.114.21 --- 0x2
```

Internet Address	Physical Address	Type
160.45.114.1	00-12-79-8d-68-00	dynamic
160.45.114.28	00-14-32-49-c1-aa	dynamic
160.45.114.29	00-04-15-d8-53-cb	dynamic
160.45.114.30	00-04-85-8b-9a-ac	dynamic
160.45.114.31	00-19-f9-18-82-3d	dynamic
160.45.114.34	00-04-25-8b-a8-8e	dynamic

Some Tools: Route

- Route
 - Display and set routing table entries

```
x:\W>route PRINT
=====
Interface List
0x1 ..... MS TCP Loopback interface
0x2 ...00 1a a0 b7 41 39 ..... Broadcom NetXtreme 57xx Gigabit Controller
=====
Active Routes:
Network Destination        Netmask          Gateway          Interface        Metric
0.0.0.0                    0.0.0.0          160.45.114.1    160.45.114.21    10
127.0.0.0                  255.0.0.0        127.0.0.1       127.0.0.1        1
160.45.114.0              255.255.255.192  160.45.114.21   160.45.114.21    10
160.45.114.21             255.255.255.255  127.0.0.1       127.0.0.1        10
160.45.255.255            255.255.255.255  160.45.114.21   160.45.114.21    10
224.0.0.0                 240.0.0.0        160.45.114.21   160.45.114.21    10
255.255.255.255          255.255.255.255  160.45.114.21   160.45.114.21    1
Default Gateway:          160.45.114.1
=====
Persistent Routes:
None
```

Some Tools: Ping

- Ping
 - Tool to test whether a host is reachable/alive

```
x:W>ping www.google.com
```

```
Pinging www.l.google.com [209.85.135.104] with 32 bytes of data:
```

```
Reply from 209.85.135.104: bytes=32 time=26ms TTL=243
```

```
Reply from 209.85.135.104: bytes=32 time=24ms TTL=243
```

```
Reply from 209.85.135.104: bytes=32 time=23ms TTL=243
```

```
Reply from 209.85.135.104: bytes=32 time=24ms TTL=243
```

```
Ping statistics for 209.85.135.104:
```

```
    Packets: Sent = 4, Received = 4, Lost = 0 (0% loss),
```

```
    Approximate round trip times in milli-seconds:
```

```
        Minimum = 23ms, Maximum = 26ms, Average = 24ms
```

Some Tools: Traceroute

- Traceroute/tracert
 - Tool to determine the used path in the Internet

```
x:\W>tracert www.google.com
```

```
Tracing route to www.l.google.com [209.85.135.104]  
over a maximum of 30 hops:
```

```
  1  <1 ms    <1 ms    <1 ms    router-114.mi.fu-berlin.de [160.45.114.1]  
  2  <1 ms    <1 ms    <1 ms    pollux.mi.fu-berlin.de [160.45.113.243]  
  3  <1 ms    <1 ms    <1 ms    zedat.router.fu-berlin.de [160.45.252.181]  
  4  307 ms   <1 ms    <1 ms    ice2.spine.fu-berlin.de [130.133.98.3]  
  5  <1 ms    <1 ms    <1 ms    xr-zibl-ge8-3.x-win.dfn.de [188.1.33.46]  
  6  *         *         *         Request timed out.  
  7  18 ms    15 ms    15 ms    zr-fra1-te0-0-0-3.x-win.dfn.de [80.81.192.222]  
  8  28 ms    15 ms    15 ms    de-cix10.net.google.com [80.81.192.108]  
  9  16 ms    16 ms    15 ms    209.85.255.172  
 10  24 ms    23 ms    24 ms    72.14.233.106  
 11  24 ms    24 ms    23 ms    66.249.94.83  
 12  26 ms    27 ms    26 ms    209.85.253.22  
 13  24 ms    24 ms    24 ms    mu-in-f104.google.com [209.85.135.104]
```

```
Trace complete.
```

Some Tools: Pathping (1)

- Pathping
 - Combination of ping and traceroute (only for Windows)
 - mtr (my traceroute) for Linux

```
x:W>pathping www.google.com
```

```
Tracing route to www.l.google.com [209.85.135.147]  
over a maximum of 30 hops:
```

```
 0  KAFPOT.pcpool.mi.fu-berlin.de [160.45.114.21]  
 1  router-114.mi.fu-berlin.de [160.45.114.1]  
 2  pollux.mi.fu-berlin.de [160.45.113.243]  
 3  zedat.router.fu-berlin.de [160.45.252.181]  
 4  ice2.spine.fu-berlin.de [130.133.98.3]  
 5  xr-zibl-ge8-3.x-win.dfn.de [188.1.33.46]  
 6  zr-pot1-te0-7-0-2.x-win.dfn.de [188.1.145.138]  
 7  zr-fral-te0-0-0-3.x-win.dfn.de [80.81.192.222]  
 8  de-cix10.net.google.com [80.81.192.108]  
 9  209.85.255.172  
10  72.14.233.106  
11  66.249.94.85  
12  209.85.253.26  
13  mu-in-f147.google.com [209.85.135.147]
```

```
Computing statistics for 325 seconds...
```

See next slide

Some Tools: Pathping (2)

Computing statistics for 325 seconds...

Hop	RTT	Source to Here Lost/Sent = Pct	This Node/Link Lost/Sent = Pct	Address
0				KAFPOT.pcpool.mi.fu-berlin.de [160.45.114.21]
			0/ 100 = 0%	
1	0ms	0/ 100 = 0%	0/ 100 = 0%	router-114.mi.fu-berlin.de [160.45.114.1]
			0/ 100 = 0%	
2	0ms	0/ 100 = 0%	0/ 100 = 0%	pollux.mi.fu-berlin.de [160.45.113.243]
			0/ 100 = 0%	
3	3ms	0/ 100 = 0%	0/ 100 = 0%	zedat.router.fu-berlin.de [160.45.252.181]
			0/ 100 = 0%	
4	0ms	0/ 100 = 0%	0/ 100 = 0%	ice2.spine.fu-berlin.de [130.133.98.3]
			0/ 100 = 0%	
5	0ms	0/ 100 = 0%	0/ 100 = 0%	xr-zibl-ge8-3.x-win.dfn.de [188.1.33.46]
			0/ 100 = 0%	
6	1ms	0/ 100 = 0%	0/ 100 = 0%	zr-pot1-te0-7-0-2.x-win.dfn.de [188.1.145.138]
			0/ 100 = 0%	
7	14ms	93/ 100 = 93%	93/ 100 = 93%	zr-fra1-te0-0-0-3.x-win.dfn.de [80.81.192.222]
			0/ 100 = 0%	
8	17ms	0/ 100 = 0%	0/ 100 = 0%	de-cix10.net.google.com [80.81.192.108]
			0/ 100 = 0%	
9	20ms	0/ 100 = 0%	0/ 100 = 0%	209.85.255.172
			0/ 100 = 0%	
10	24ms	0/ 100 = 0%	0/ 100 = 0%	72.14.233.106
			0/ 100 = 0%	
11	29ms	0/ 100 = 0%	0/ 100 = 0%	66.249.94.85
			0/ 100 = 0%	
12	28ms	0/ 100 = 0%	0/ 100 = 0%	209.85.253.26
			1/ 100 = 1%	
13	24ms	1/ 100 = 1%	0/ 100 = 0%	mu-in-f147.google.com [209.85.135.147]

Trace complete.



Routing

Internet Layer

- Raw division into three tasks:
 - Data transfer over a global network
 - Route decision at the sub-nodes
 - Control of the network or transmission status

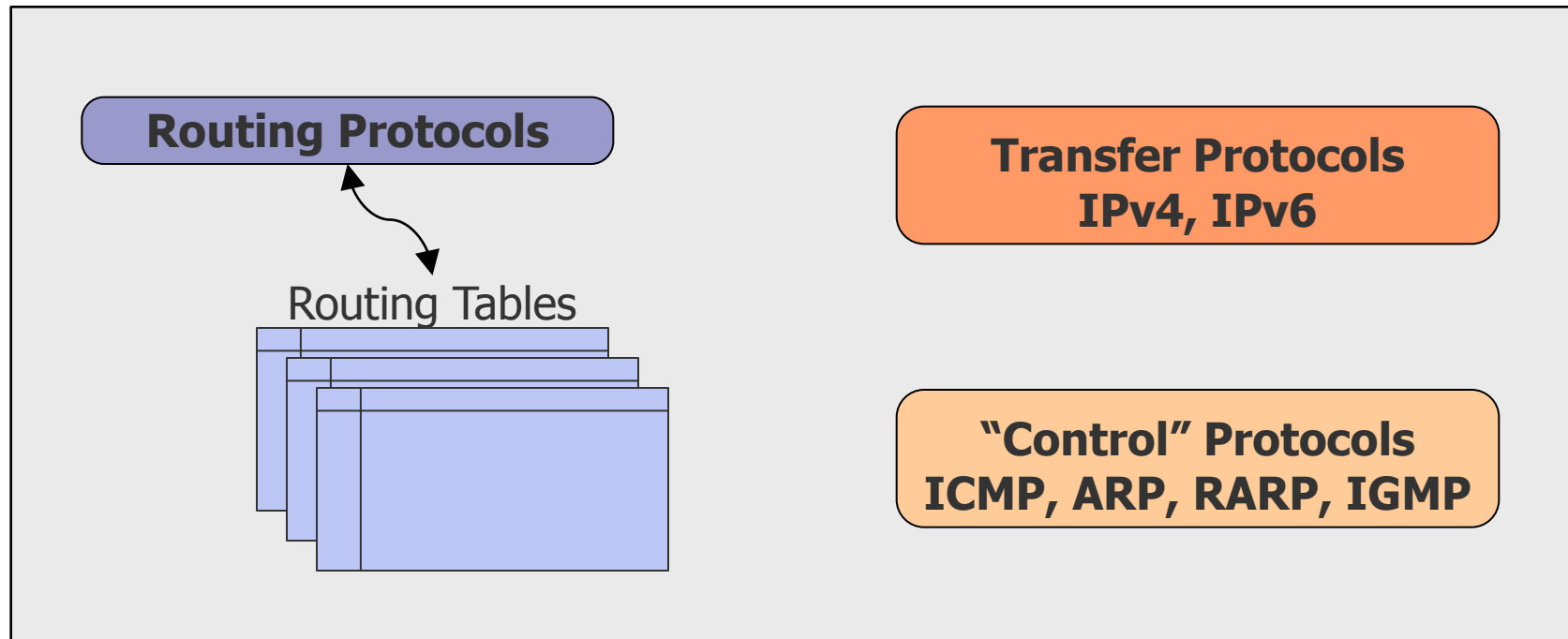

Routing Tables

Destination Address	Next Hop
12.0.0.0/8	194.52.124.1
157.216.0.0/16	142.117.1.1
142.117.0.0/16	142.117.1.1
194.52.124.0/24	194.52.124.1
0.0.0.0/0	142.117.1.1

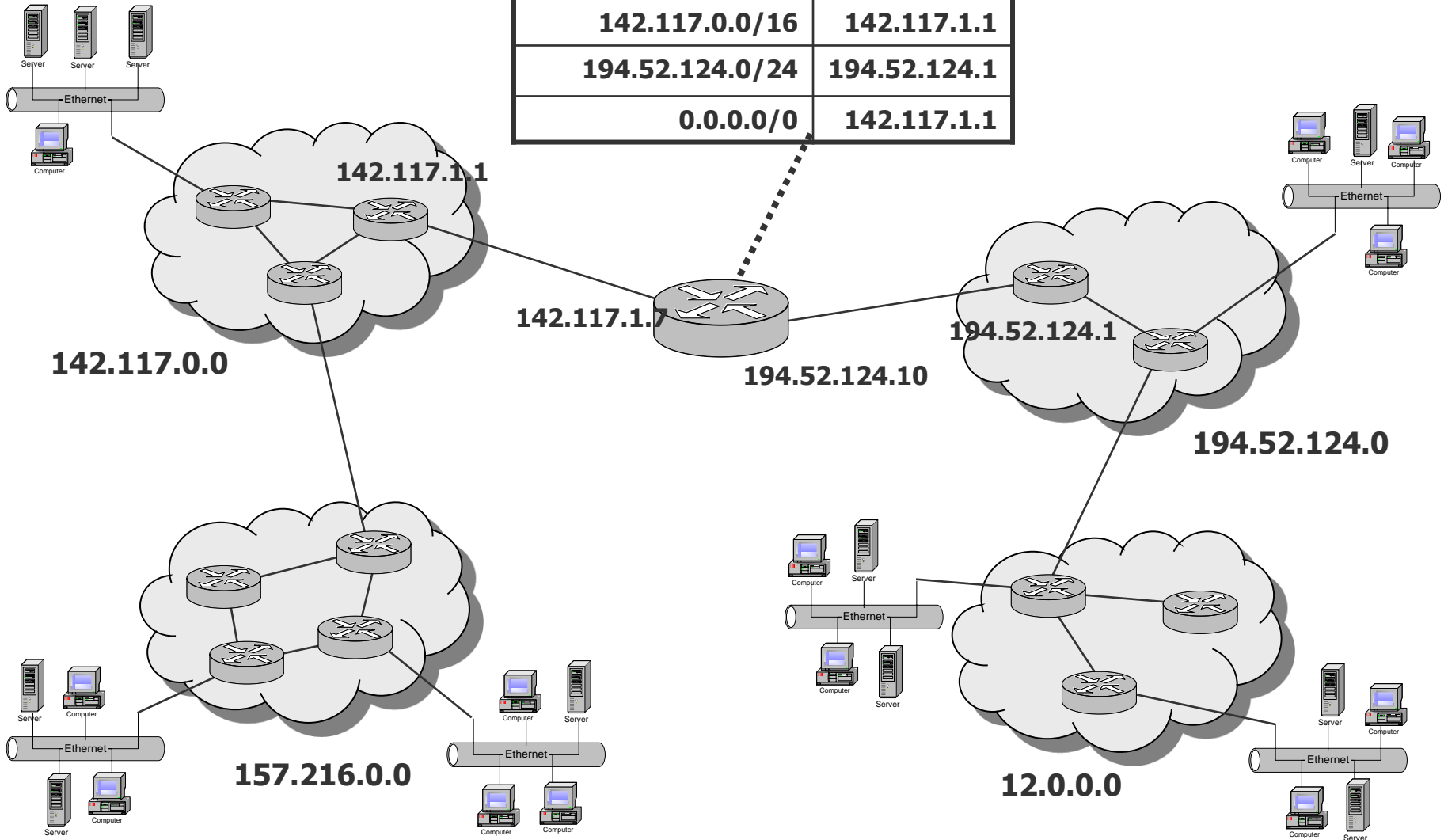

Routing in the Internet

- The Internet consists of a large number of **Autonomous Systems (AS)**
- Each autonomous system is operated by its operator and can deploy a routing protocol
- By standardization of protocols, gateways can forward packets at the borders of the autonomous systems

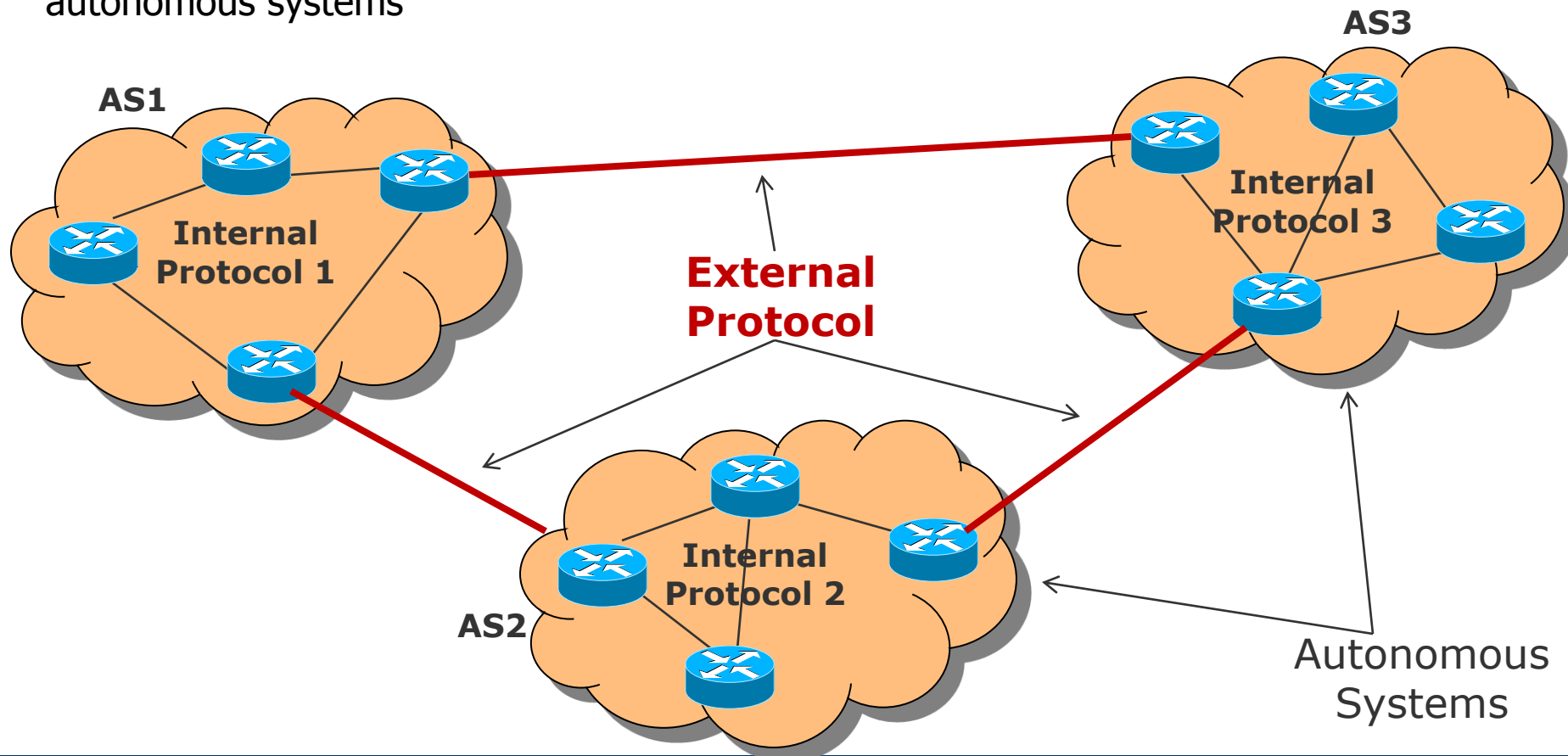

Routing Protocols

- Interior Gateway Protocols (IGP):
Routing in autonomous systems, for efficient transmission
 - Routing Information Protocol (RIP)
 - Internet Gateway Routing Protocol (IGRP)
 - Enhanced IGRP
 - Open Shortest Path First (OSPF)
 - Intermediate System to Intermediate System (IS-IS)
- Exterior Gateway Protocols (EGP):
Routing between domains, adherence of policies for the domains
 - Border Gateway Protocol (BGP)
- Router Discovery Protocols
 - ICMP Router Discovery Protocol (IRDP)
 - Hot Standby Router Protocol (HSRP)

Sink or Sink Tree

- As result of the optimization principle a Sink or Sink Tree is constructed (here for router B)
- The Sink Tree contains no loops
- The Sink Tree can be used as a good indicator for the quality of a routing algorithm
- A Sink Tree can change immediately (e.g. by crash of a router or by loss of a link)

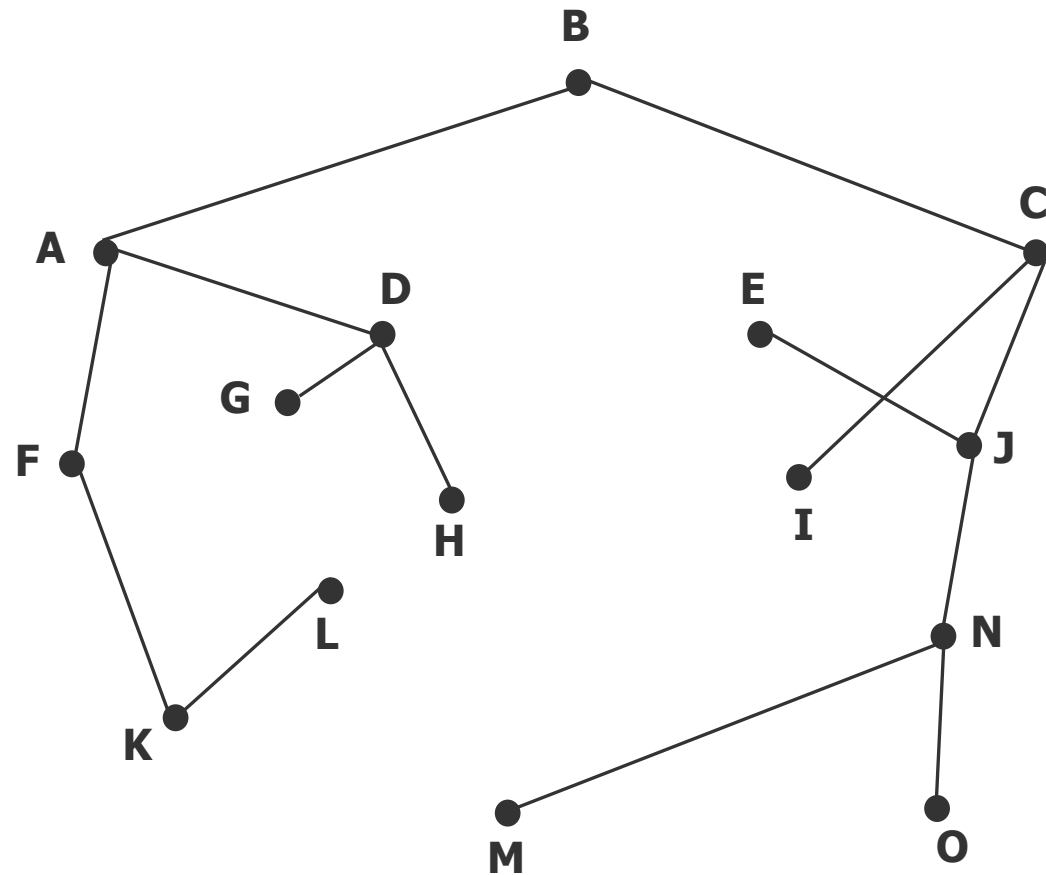

Routing Algorithms: Graph abstraction

- Abstraction of a computer network as a graph
- Graph: $G = (N, E)$
 - $N = \text{set of routers} = \{ u, v, w, x, y, z \}$
 - $E = \text{set of links} = \{ (u,v), (u,x), (v,x), (v,w), (x,w), (x,y), (w,y), (w,z), (y,z) \}$

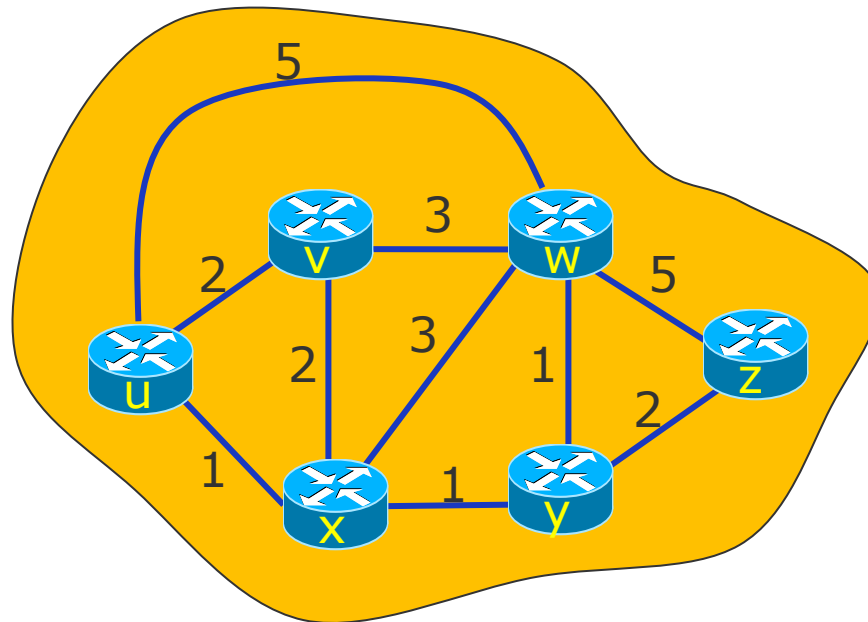

Routing Algorithms: Graph abstraction

- Cost of a link

- $c(x, x') = \text{cost of link } (x, x')$

- e.g., $c(w, z) = 5$

- Cost could always be 1, or inversely related to bandwidth, or inversely related to congestion

- Cost \sim routing metric

- Cost of a path

- $c(x_1, x_2, x_3, \dots, x_p) = c(x_1, x_2) + c(x_2, x_3) + \dots + c(x_{p-1}, x_p)$

- Question: What's the least-cost path between u and z ?

- **Routing algorithm: algorithm that finds the least-cost path**

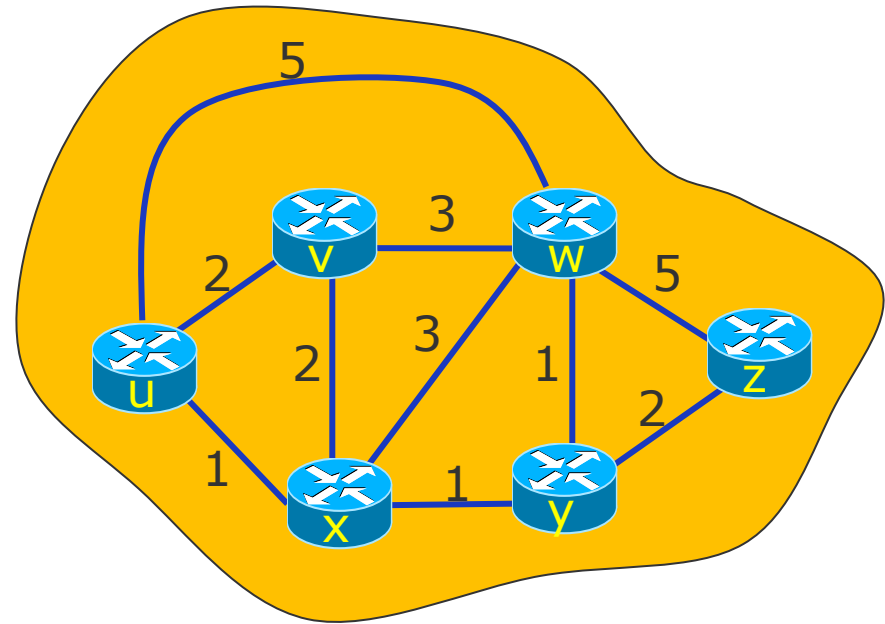

Routing Algorithms: Taxonomy

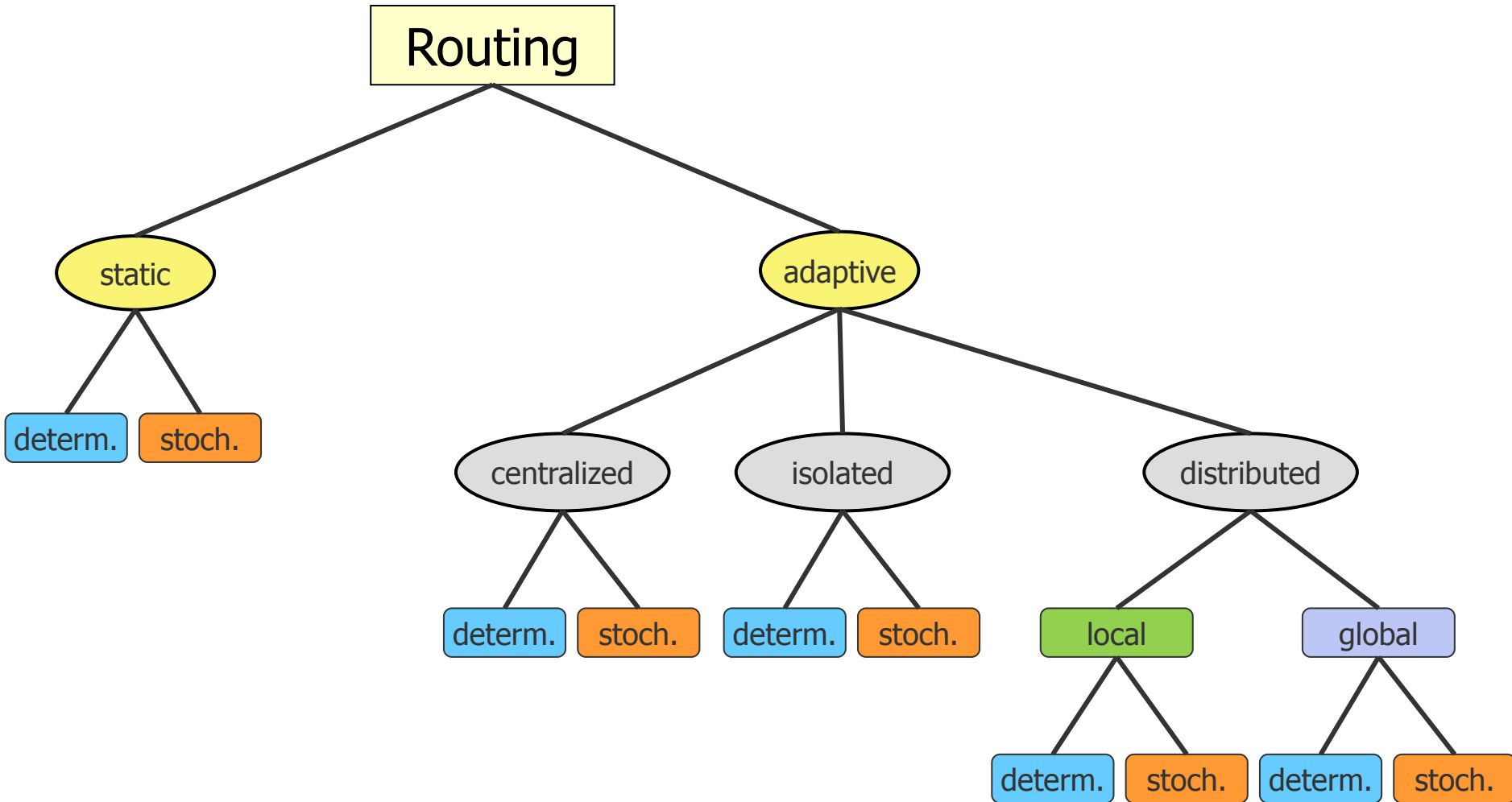



Routing

Static Routing

Static Routing

- Source Routing
 - Route is determined by the source node
 - Whole path is included in each packet

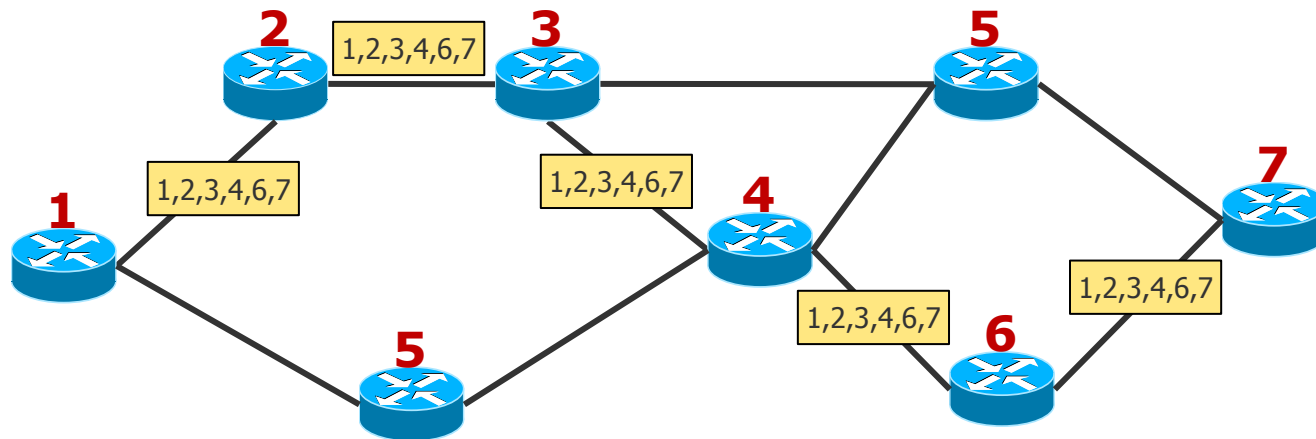

- Problem: How does the source node know the whole path?

Static Routing

● Internal Routing

- Routing decision by intermediate nodes
- Static tables are used within the routers, no reaction to changes in the network
- Stable
- Simple
- No reaction to changing network conditions
- Breakdowns in links or routers can have catastrophic results

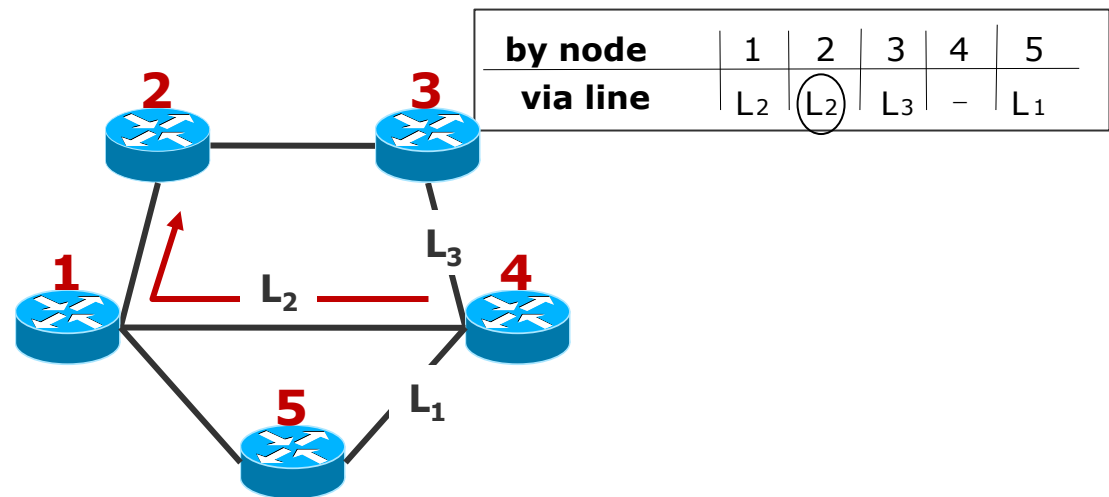

Static Routing

- Flooding Principle
 - Flooding of the network with copies of the data packet
 - Router propagates packet over all links, except over the incoming one
- Characteristics
 - High reliability (in case of failure of single routers)
 - Meaningful for military applications (**robustness**)
 - But: large number of copied packets (**overhead**)
 - Possible loops are problematic
 - Hop counter (TTL)
 - List of all packets already sent
 - Usable as reference for the quality of routing algorithms (**delay**)
 - Used to support other routing algorithms, e.g., OSPF

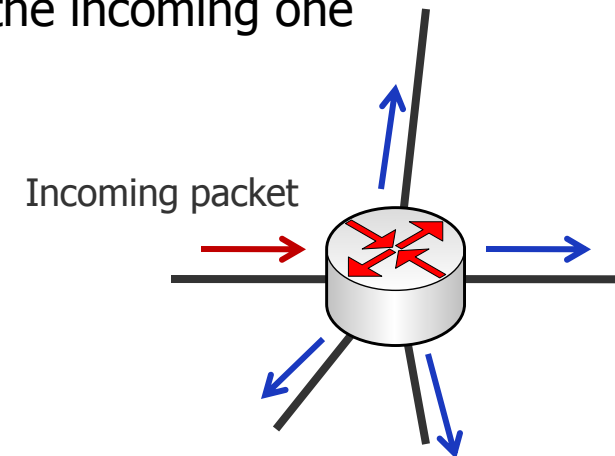

Static Routing

- Network Control Center (NCC)
 - Adaptive, centralized technique
 - The central control center collects information about the network state
 - The NCC provides routing strategies and network information in regular time intervals to all routers
 - Routing decisions are made locally by routers
 - Useful only for very small networks...
 - collecting network state information needs time
 - the transmission of these information to the routers is expensive
 - information maybe outdated until it comes to the routers

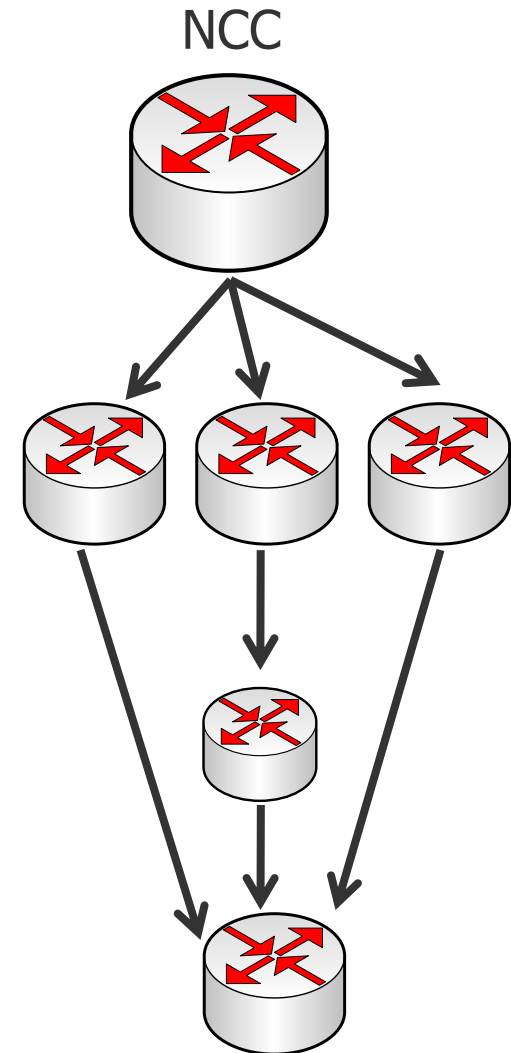

Local Estimation Procedure

	Via Line		
to Router	L1	L2	L3
A	4	8	7
B	5	1	3
C	6	4	3

min →

Router	Via
A	L1
B	L2
C	L3

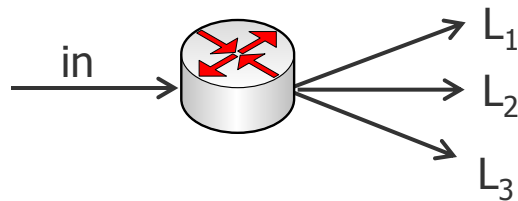

- Routing takes place on the basis of transmission delay estimations
- Every router “estimates” for itself
- Problem: Routers cannot see the whole network

Hot Potato Routing

- Choose the outgoing link with the lowest load for the next packet

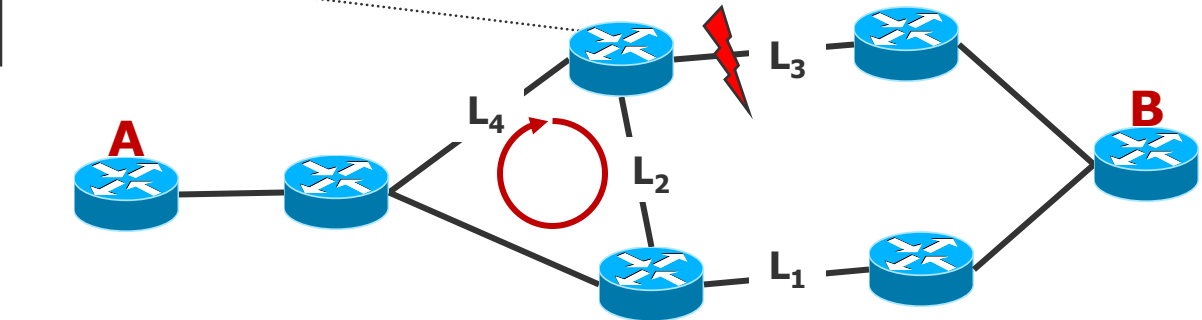
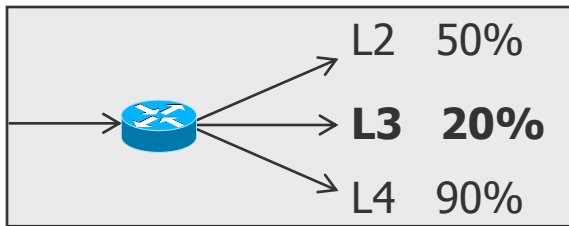

- Problem: "circling" of messages
- Solution: carry a list of the visited routers
- There are two variants:
 - "Hot Potato": Shortest Queue without Bias
 - "Hot Potato" with carried router list: Shortest Queue with Bias

Probabilistic Routing

- Router decides regarding performance measures of sent packets (e.g. delay, jitter) about best routes for a packet
- Routing can be made proportionally by assigning a proportionality factor p_i to each link L_i

A	L	p(L)
	1	25%
	2	25%
	3	30%
	4	20%
B	L	p(L)
	1	75%
	2	25%
	3	-
	4	-

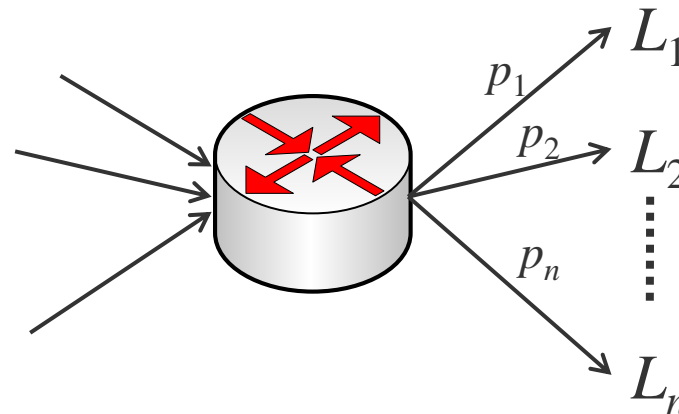

Routing

Shortest Path Routing

Routing: Shortest Path

- Static variant

- Router administrates a table with distances to each destination and lines to be used
- Based on a constant metric
 - Distance, line costs, transmission capacity, etc.
- Computation of the shortest path (regarding the metric)
 - According to **Dijkstra's algorithm**

- Adaptive variant

- Dynamic routing algorithms
- Dynamic metrics (e.g. current delay, actual transmission capacity)
- (Regular) update of the routing tables

Routing

Shortest Path Routing
Disjkstra

Shortest Path: Dijkstra (1)

- Algorithm of Dijkstra (1959) for static Routing
 1. Mark source node (the **work node**) as **permanent**, i.e., distance and line do not change any more
 2. Consider **neighbor nodes** of the node currently marked as **permanent**, i.e., the **work node**, and compute the distance to them **based on** own knowledge and **link costs**
 3. Choose the node with the **smallest distance** to the source from the nodes not marked yet and mark it as **permanent**, it becomes the new **work node**.
Goto 2.

Shortest Path: Dijkstra (2)

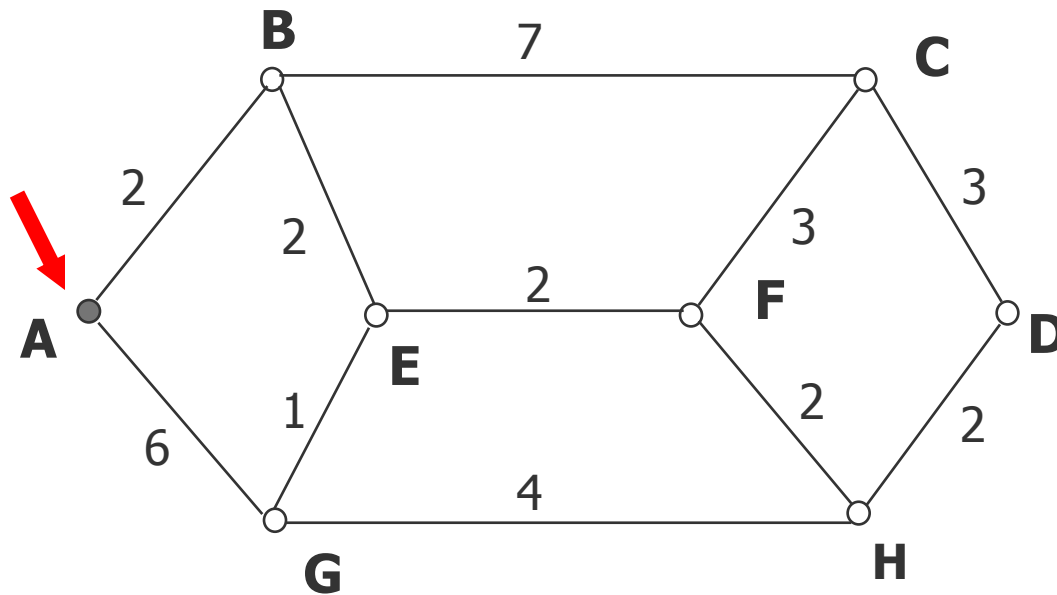

As metric, exemplarily the distance in kilometers is chosen.

The shortest path from A to D is searched.

1. Step: Marking of node A as permanent.

2. Step: Marking of the neighbor nodes of A.



Shortest Path: Dijkstra (3)

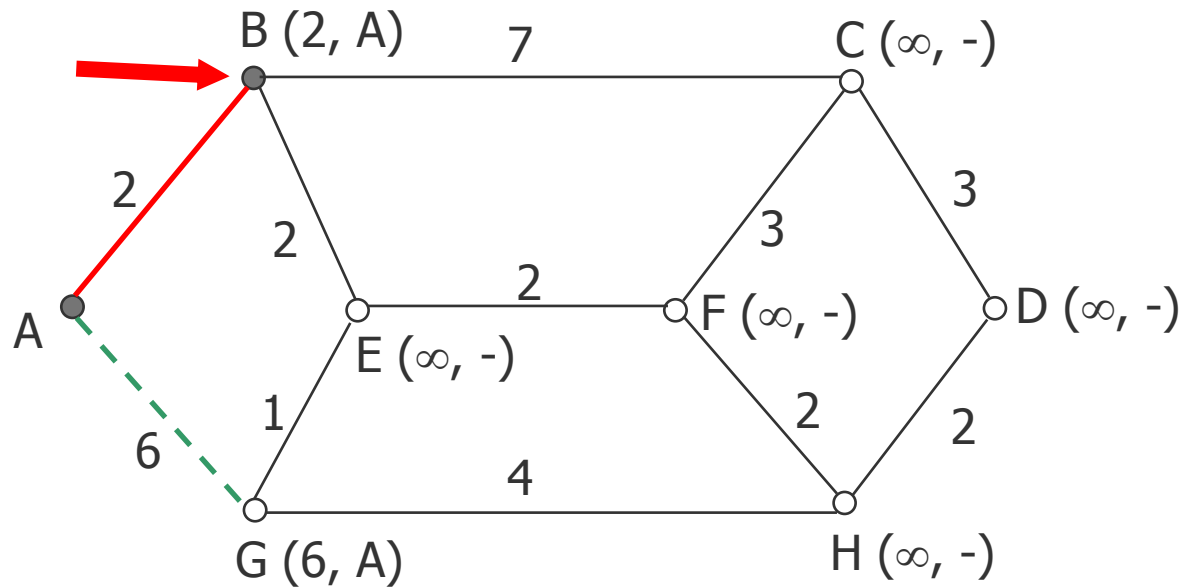

In order to be able to trace back the path later on, the predecessor node is stored.

3. Step: B becomes permanent, because the distance to A is 2 (< 6).

4. Step: Tentative labeling of the neighbor nodes of B.



Shortest Path: Dijkstra (4)

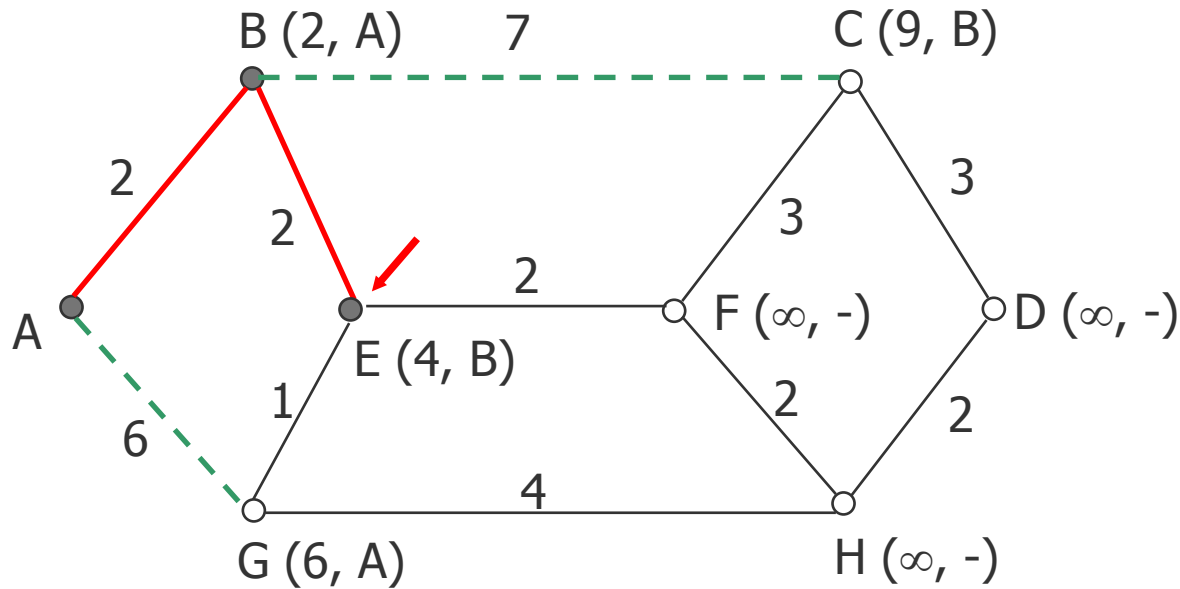

5. Step: E becomes permanent, since the distance to A is $4 (< 6 < 9)$.

6. Step: Tentative labeling of the neighbor nodes of E.

E (4, B): Distance of A to E sums up to 4 using the path BE.

Shortest Path: Dijkstra (5)

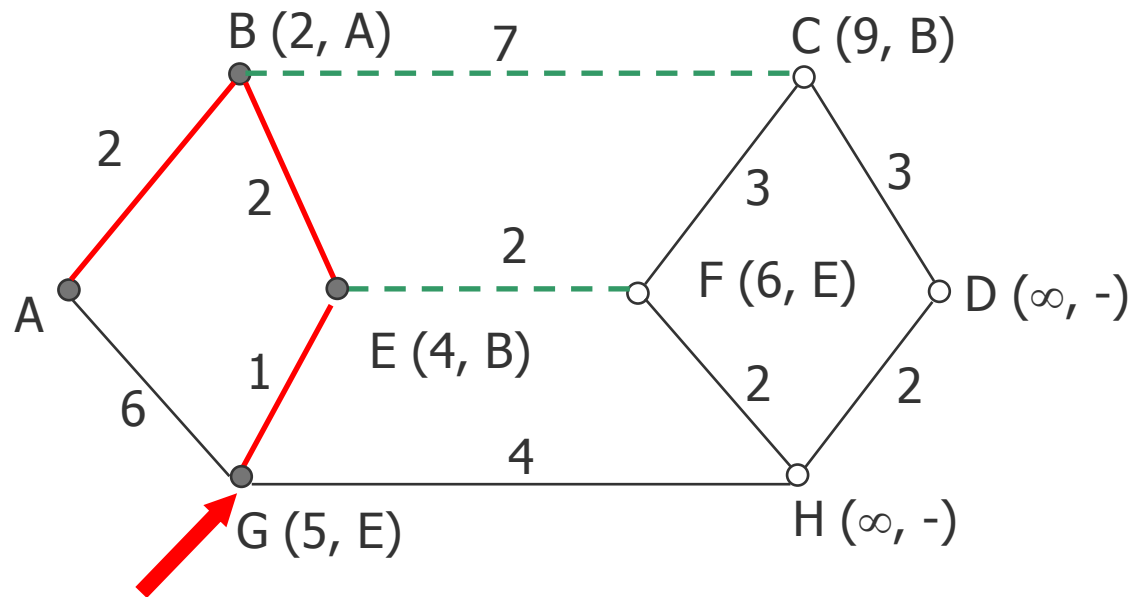

5. Step: Preliminary label of G is over-written.

6. Step: G becomes permanent, since the distance to A is $5 (< 6 < 9)$.

7. Step: Tentative labeling of the neighbor nodes of G.

Shortest Path: Dijkstra (6)

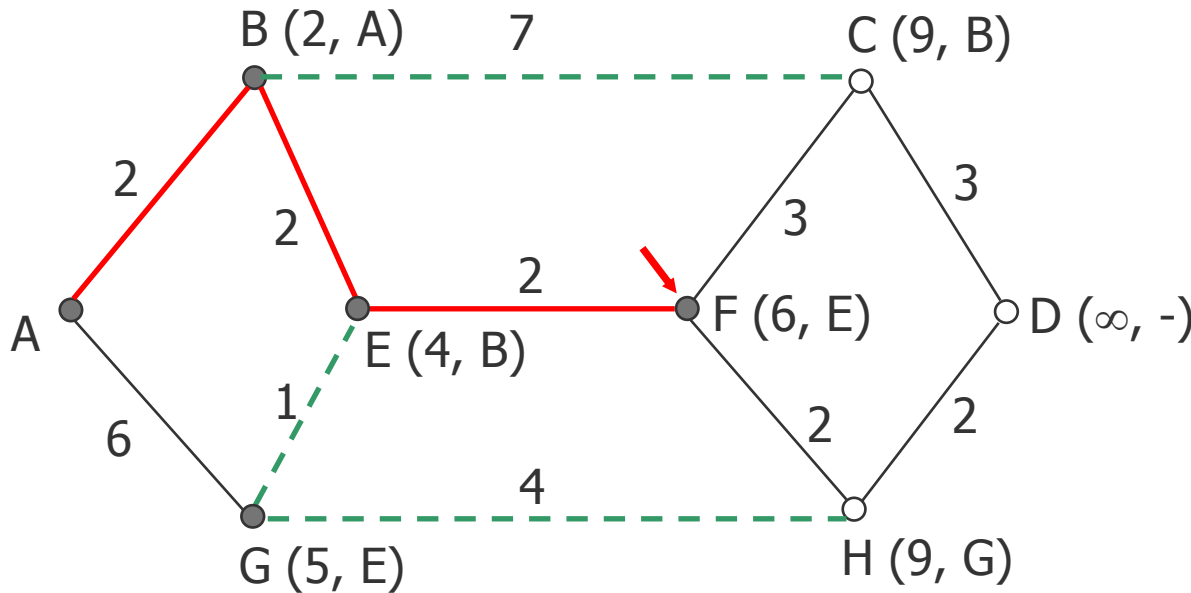

8. Step: Tentative label of G is overwritten.

9. Step: F becomes permanent, since the distance to A is 6 (< 9).

10. Step: Tentative labeling of the neighbor nodes of F.



Shortest Path: Dijkstra (7)

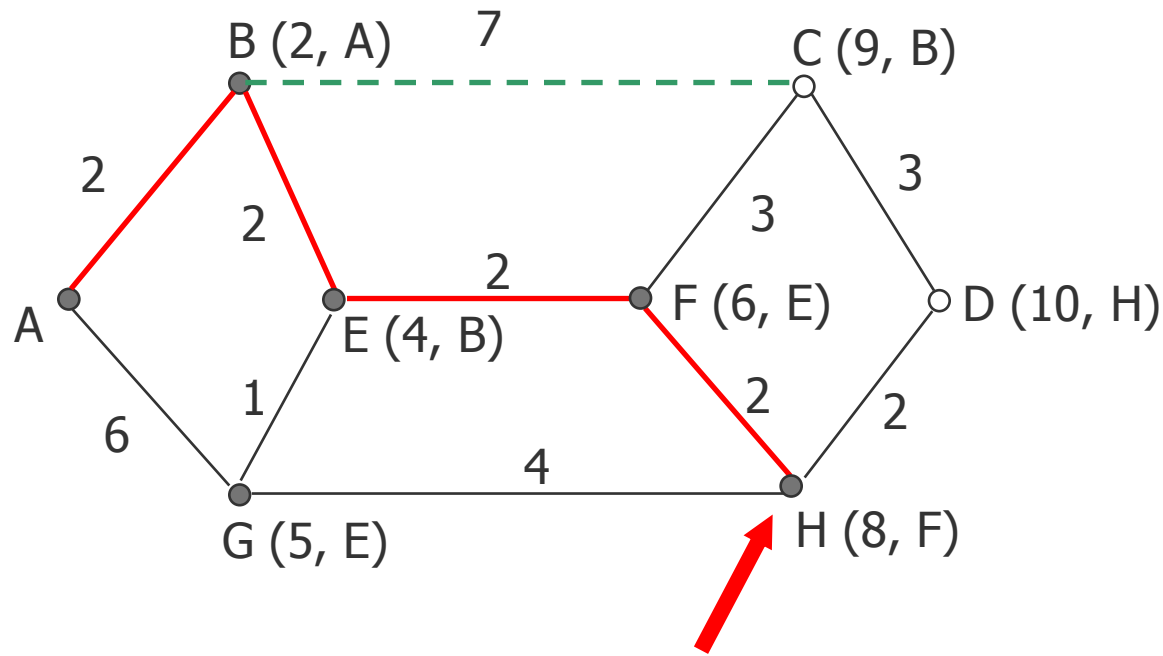

11. Step: H becomes permanent, since the distance to A is 8 (< 9).

12. Step: Tentative labeling of the neighbor nodes of H.

13. Step: C becomes permanent, since the distance to A is 9 (< 10).



Shortest Path: Dijkstra (8)

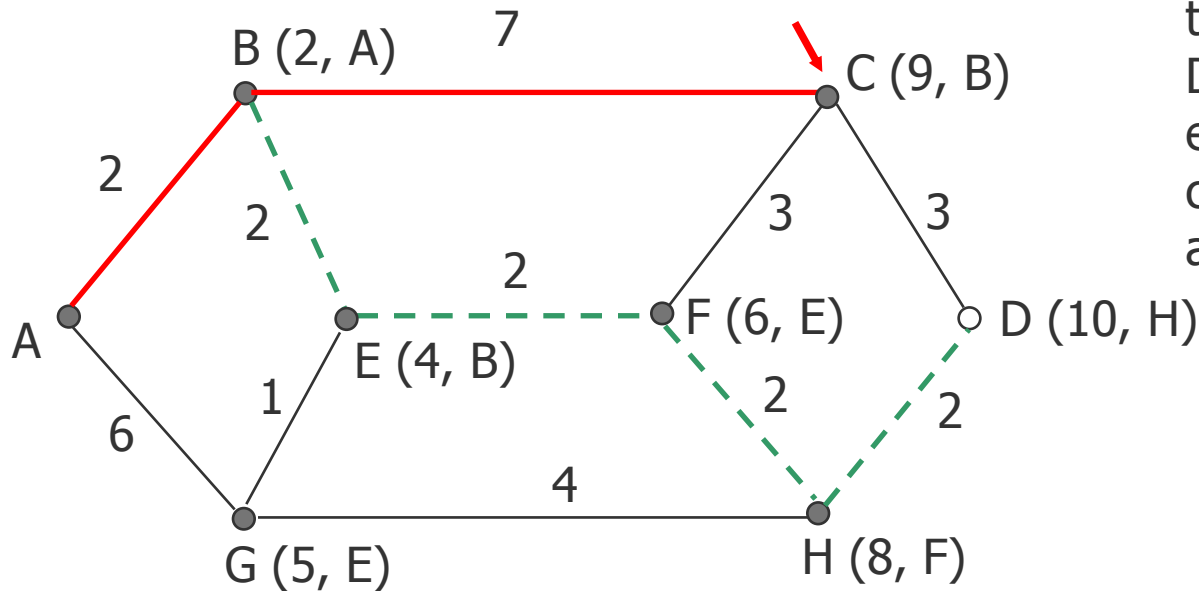

The distance to D using C is larger than the tentative label of D. No more paths exist, no states are changed - the algorithm terminates.

Shortest Path: Dijkstra (9)

14. Step: D is reached on the shortest path and finally becomes permanent.

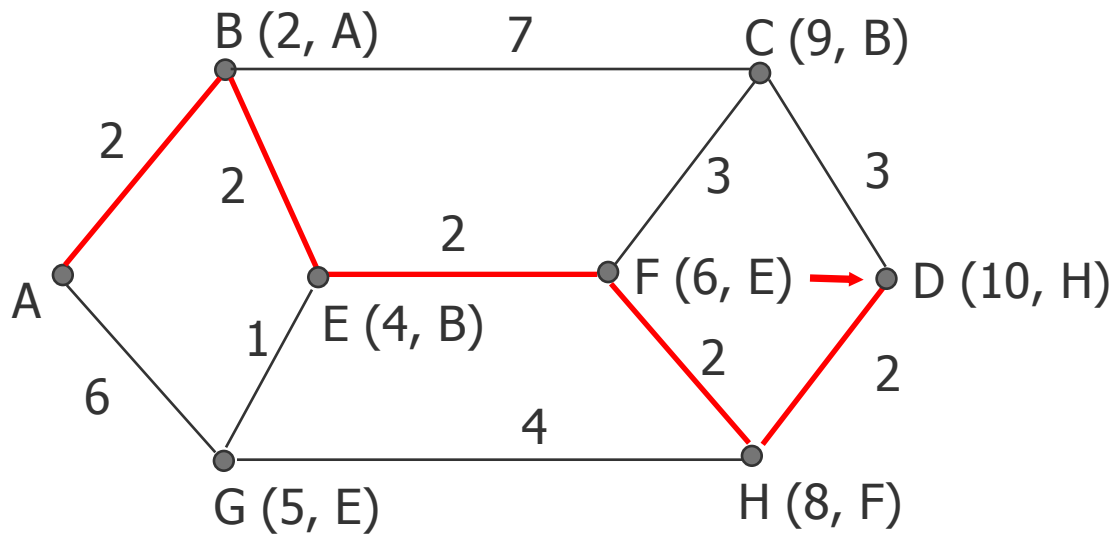

Implementation of Dijkstra (1)

```

#define MAX_NODES 1024                /* maximum number of nodes */
#define INFINITY 1000000000          /* a number larger than every maximum path */
int n;
int dist[MAX_NODES][MAX_NODES];      /* dist[i][j] is the distance from i to j */

void shortest_path(int s, int t, int path[])
{
    struct state {                    /* s = source node, t = terminal node */
        int predecessor;              /* the path being worked on */
        int length;                   /* previous node */
        enum {permanent, tentative} label; /* length from source to this node */
    } state[MAX_NODES];              /* label state */

    int i, k, min;
    struct state *p;

    for (p = &state[0]; p < &state[n]; p++) { /* initialize state */
        p->predecessor = -1;
        p->length = INFINITY;
        p->label = tentative;
    }

    state[t].length = 0;
    state[t].label = permanent;
    k = t;                               /* k is the initial working node */
                                           /* The algorithm starts with the terminal node */
}

```

// Next Slide

Implementation of Dijkstra (2)

```
do {
    /* Is there a better path from k? */
    for (i = 0; i < n; i++) /* this graph has n nodes */
        if (dist[k][i] != 0 && state[i].label == tentative) {
            if (state[k].length + dist[k][i] < state[i].length) {
                state[i].predecessor = k;
                state[i].length = state[k].length + dist[k][i];
            }
        }
    /* Find the tentatively labeled node with the smallest label. */
    k = 0;
    min = INFINITY;
    for (i = 0; i < n; i++)
        if (state[i].label == tentative && state[i].length < min) {
            min = state[i].length;
            k = i;
        }
    state[k].label = permanent;
} while (k != s);

/* Copy the path into the output array. */
i = 0;
k = s;
do {
    path[i++] = k;
    k = state[k].predecessor;
} while (k >= 0);

} // shortest_path
```



Routing

Distance Vector Routing

Distance Vector Routing

- Problem: Static routing approaches are **inflexible**, they do not react to problems
- Solution: Routers mutually exchange (regularly) information about the current state of outgoing lines
- Distance Vector Routing
 - Adaptive variant of shortest path routing
 - Bellman et al. 1957
- Related names
 - Distributed Bellmann-Ford Routing
 - Ford-Fulkerson Routing
 - RIP (ARPANET, Internet); improved in Cisco routers
- Properties of the Distance Vector Routing
 - Shortest-path routing
 - Distributed
 - Iterative
 - Asynchronous
 - Self-terminating

Distance Vector Routing

- The Distance Vector Routing
 - Every router manages a table with (known/estimated) distances to each destination and the assigned lines to neighbor nodes
 - Each router is assumed to know the distances to its neighbors
 - Regularly, the distance information of the routing tables is communicated to the neighbors
 - Based on the information from the neighbors and the known distances to the neighbors every router re-computes its routing table
 - Without the use of the own old routing information
 - Example of a Distance Vector: $DV_j = [(A=2), (B=3), (C=1), \dots]$
 - A is reachable with costs 2
 - B is reachable with costs 3
 - C is reachable with costs 1

Distance Vector Routing

Distance Vector Algorithm

```
1  Initialization:
2    for all destinations y in N:
3       $D_x(y) = c(x,y)$            // if y is not a neighbor then  $c(x,y) = \infty$ 
4    for each neighbor w
5       $D_w(y) = \infty$  for all destinations y in N
6    for each neighbor w
7      send distance vector  $DV_x = [D_x(y) : y \text{ in } N]$  to w
8
9  Loop:
10   wait (until I see a link cost change to some neighbor w or
11         until I receive a distance vector from some neighbor w)
12
13   for each y in N:
14      $D_x(y) = \min_v \{c(x,v) + D_v(y)\}$ 
15
16   if  $D_x(y)$  changed for any destination y
17     send distance vector  $DV_x = [D_x(y) : y \text{ in } N]$  to all neighbors
```

Terms

- $c(x,y)$ Cost of link (x,y)
- $D_x(y)$ Distance from node x to y
- DV_x Distance vector of node x



Distance Vector Routing: Information Exchange

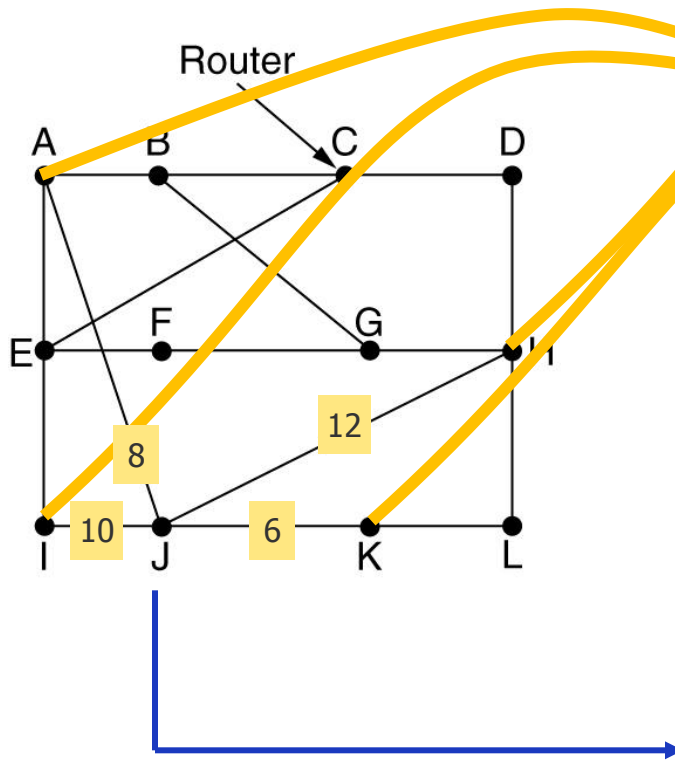

To	A	I	H	K	New estimated delay from J	
					↓	Line
A	0	24	20	21	8	A
B	12	36	31	28	20	A
C	25	18	19	36	28	I
D	40	27	8	24	20	H
E	14	7	30	22	17	I
F	23	20	19	40	30	I
G	18	31	6	31	18	H
H	17	20	0	19	12	H
I	21	0	14	22	10	I
J	9	11	7	10	0	–
K	24	22	22	0	6	K
L	29	33	9	9	15	K

Vectors received from J's four neighbors
New routing table for J

Essential here:

Global information is exchanged only between neighbors!

Estimation of J for its neighbors
 $J_A = 8, J_I = 10, J_H = 12, J_K = 6$

Distance Vector Routing: Example

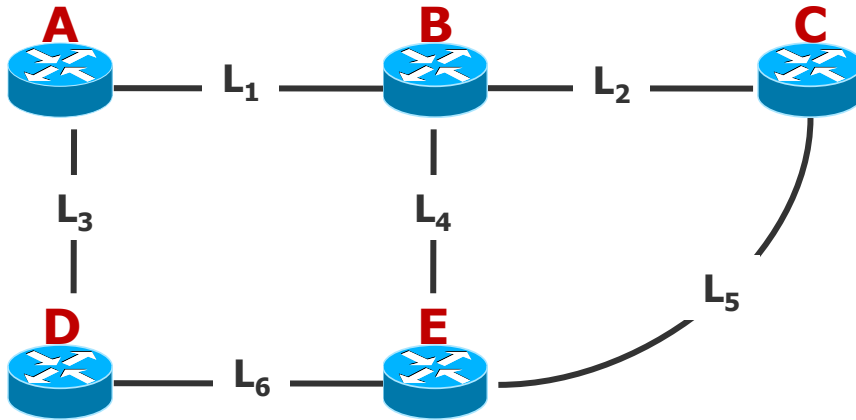

As "transmission costs" for each line, 1 is assumed.

Table of router A after system initialization or "cold start"

From A to	Link	Costs
A	Locally	0

Table of router B after system initialization or "cold start"

From B to	Link	Costs
B	Locally	0



Distance Vector Routing: Example

- A transfers (A=0) to its neighbors B and D.
- B and D know from where the vector comes and so the costs to A can be computed.

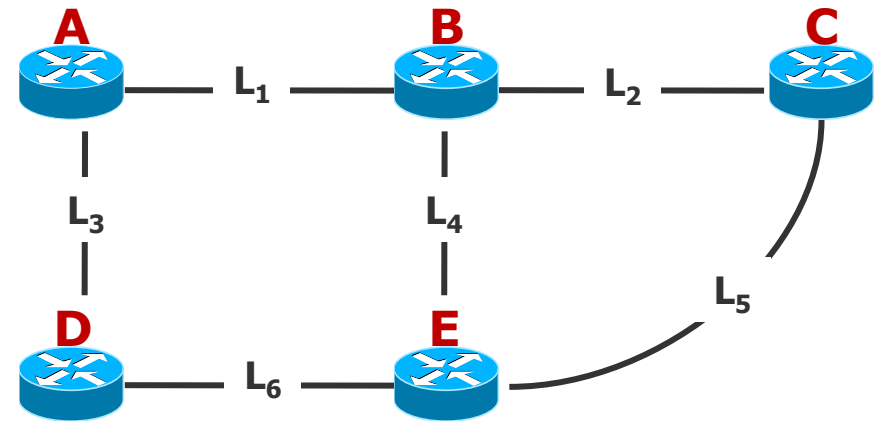

- Routing tables of routers B and D, after the vector of router A is processed.

From B to	Link	Costs
B	Locally	0
A	L1	1

From D to	Link	Costs
D	Locally	0
A	L3	1



Distance Vector Routing: Example

B now transfers its vector (B=0, A=1) using link L1, L2, and L4 to its neighbors A, C, and E.

A receives this vector over link L1 and updates its table as follows:

A=2 is larger than A=0 ➡ discard B=1 for link L1

Similar to this, the vector of D is processed.

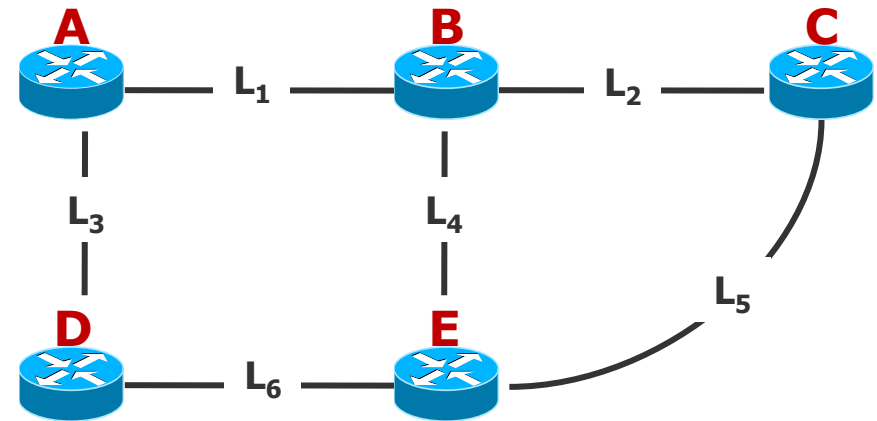

Routing table of A after updating with information coming from D and B

From A to	Link	Costs
A	Locally	0
B	L1	1
D	L3	1

Distance Vector Routing: Example

Router C receives (B=0, A=1)

From C to	Link	Costs
C	Locally	0
B	L2	1
A	L2	2

Router E receives (B=0, A=1)

From E to	Link	Costs
E	Locally	0
B	L4	1
A	L4	2

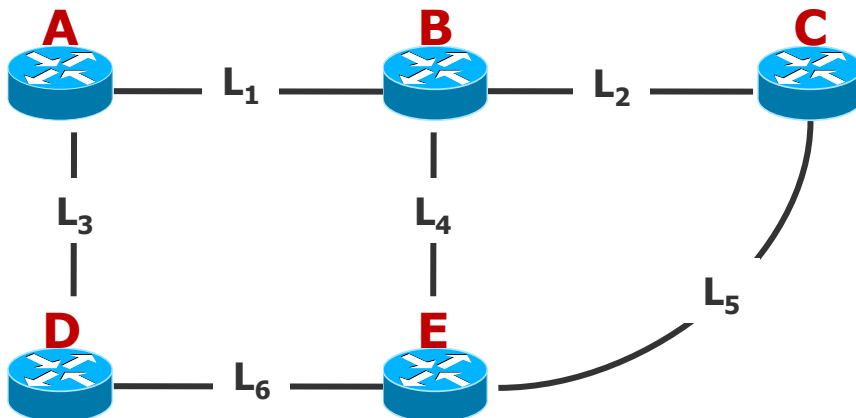



Distance Vector Routing: Example

Router E receives the vector (D=0, A=1) which it uses to update the routing table with D=1 and A=2 using link L6.

The entry for A over link L4 is already registered with costs of 2, therefore no new entry for A is necessary.

Routing table of E after the update.

A, C, and E now have new routing tables.

➔ generate distance vectors

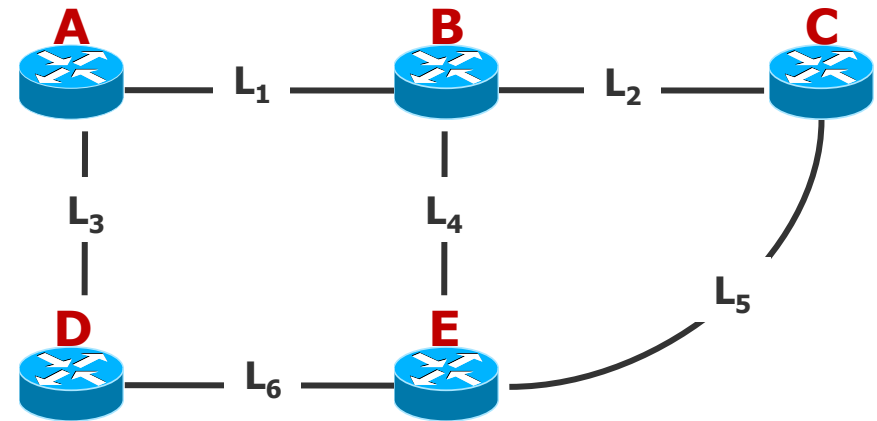

From E to	Link	Costs
E	Locally	0
B	L4	1
A	L4	2
D	L6	1



Distance Vector Routing: Example

From A: (A=0, B=1, D=1)
over link L1 and L3.

From C: (C=0, B=1, A=2)
over link L2 and L5.

From E: (E=0, B=1, A=2, D=1)
over link L4, L5, and L6.

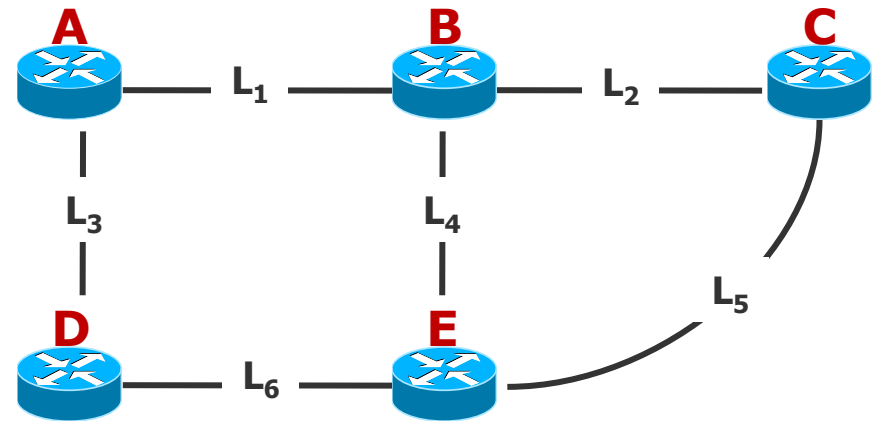

Routing table of B:

From B to	Link	Costs
B	Locally	0
A	L1	1
D	L1	2
C	L2	1
E	L4	1



Distance Vector Routing: Example

From A: (A=0, B=1, D=1) over link L1 and L3.

From C: (C=0, B=1, A=2) over link L2 and L5.

From E: (E=0, B=1, A=2, D=1) over link L4, L5, and L6.

From D to	Link	Costs
D	Locally	0
A	L3	1
B	L3	2
E	L6	1

From E to	Link	Costs
E	Locally	0
B	L4	1
A	L4	2
D	L6	1
C	L5	1

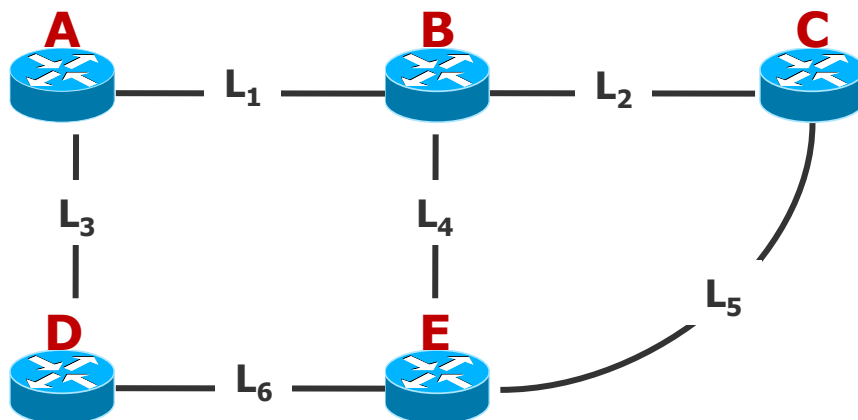



Distance Vector Routing: Example

From B: (B=0, A=1, D=1, C=1, E=1) over link L1, L3, and L4.

From D: (D=0, A=1, B=2, E=1) over link L3 and L6.

From E: (E=0, B=1, A=2, D=1, C=1) over link L4, L5, and L6.

From A to	Link	Costs
A	Locally	0
B	L1	1
D	L3	1
C	L1	2
E	L1	2

From C to	Link	Costs
C	Locally	0
B	L2	1
A	L2	2
E	L5	1
D	L5	2

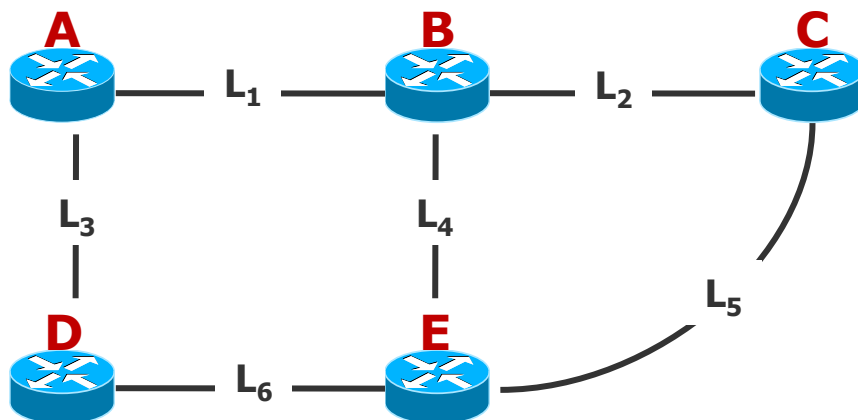

Distance Vector Routing: Example

From B: (B=0, A=1, D=1, C=1, E=1)
over link L1, L3, and L4.

From D: (D=0, A=1, B=2, E=1) over
link L3 and L6.

From E: (E=0, B=1, A=2, D=1, C=1)
over link L4, L5, and L6.

From D to	Link	Costs
D	Locally	0
A	L3	1
B	L3	2
E	L6	1
C	L6	2

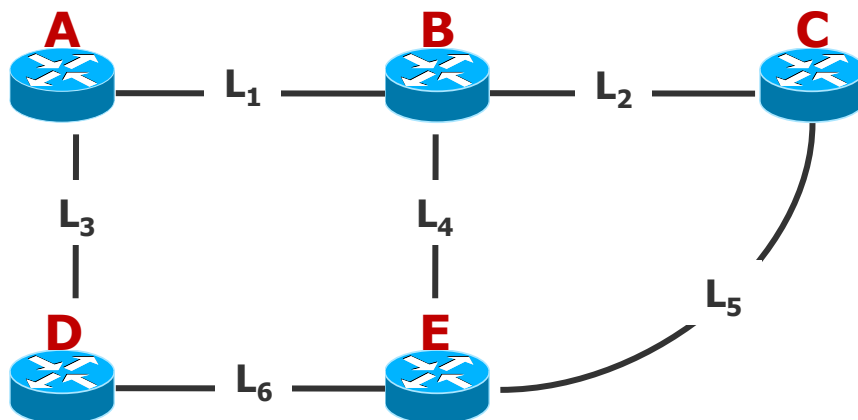

The algorithm terminates since A, C, and D create and send new vectors, but B, D, and E do not have to apply updates any longer.

Distance Vector Routing: Successive Information Propagation

- Problem with this procedure: Information must be reliable
- Otherwise: Christmas Deadlock
 - A router j announced $DV_j = (0, \dots, 0)$
 - Consequence: Nearly the entire traffic was led over j
 - Result: Collapse
- Disadvantages:
 - Unreliable information is dangerous
 - Cycling load conditions
 - Additional overhead
 - And: information propagation lasts a certain time!

Distance Vector Routing: Connection Loss

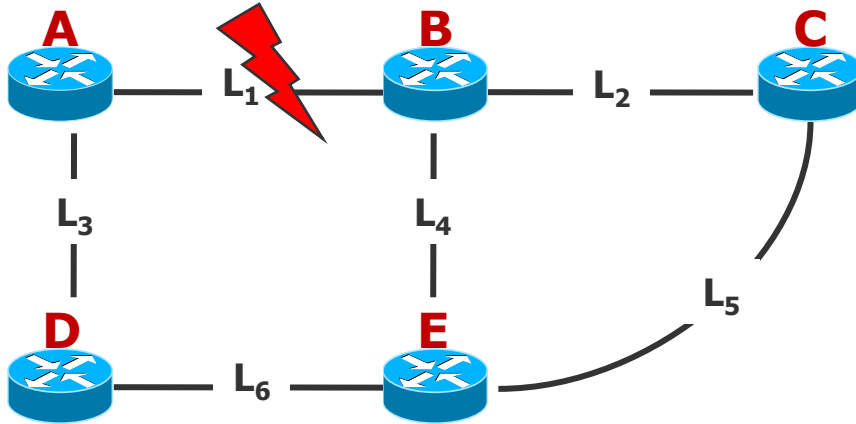

From A to	Link	Costs
A	Locally	0
B	L1	Inf
D	L3	1
C	L1	Inf
E	L1	Inf

Router A and B notice the interruption, e.g. by control packets.

➔ Update of their own routing tables

➔ Inf = Infinite

From B to	Link	Costs
B	Locally	0
A	L1	Inf
D	L1	Inf
C	L2	1
E	L4	1



Distance Vector Routing: Connection Loss

From A: (A=0, B=inf, D=1, C=inf, E=inf)
over link L3

From B: (B=0, A=inf, D=inf, C=1, E=1)
over link L2 and L4

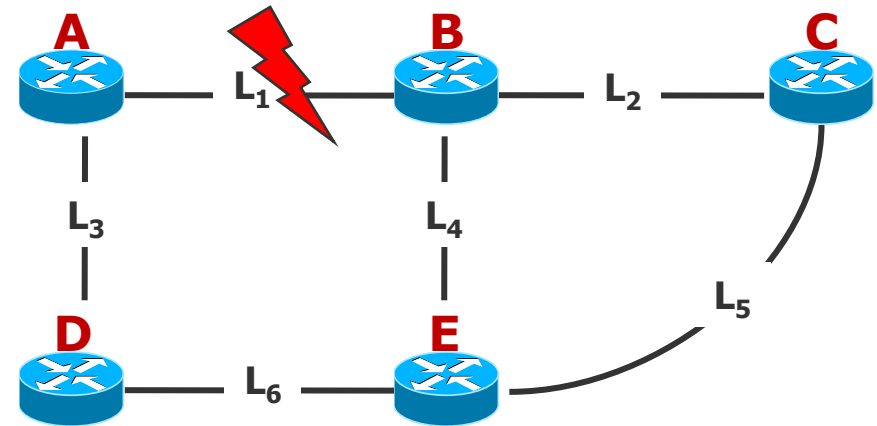

D receives the vector from A
and updates with A=1, B=inf,
D=2, C=inf, E=inf

From D to	Link	Costs
D	Locally	0
A	L3	1
B	L3	Inf
E	L6	1
C	L6	2



Distance Vector Routing: Connection Loss

From A: (A=0, B=inf, D=1, C=inf, E=inf)
over link L3

From B: (B=0, A=inf, D=inf, C=1, E=1)
over link L2 und L4

From C to	Link	Costs
C	Locally	0
B	L2	1
A	L2	Inf
E	L5	1
D	L5	2

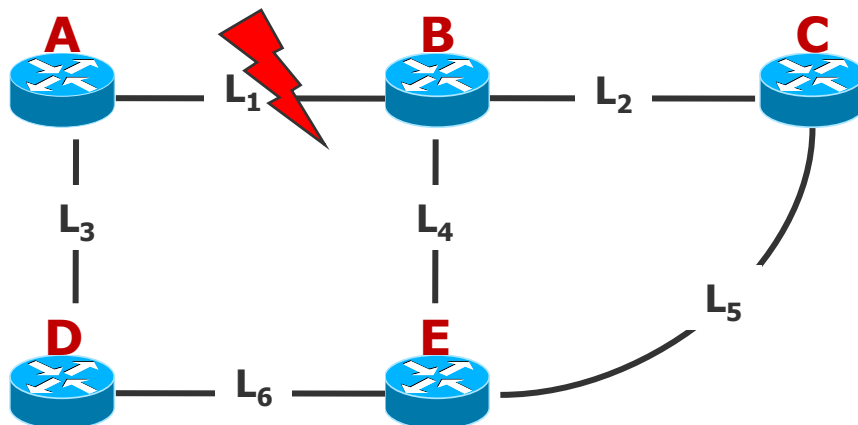

From E to	Link	Costs
E	Locally	0
B	L4	1
A	L4	Inf
D	L6	1
C	L5	1



Distance Vector Routing: Connection Loss

From D: (D=0, A=1, B=inf, E=1, C=2)
over link L3 and L6

From C: (C=0, B=1, A=inf, E=1, D=2)
over link L2 and L5

From E: (E=0, B=1, A=inf, D=1, C=1)
over link L4, L5, and L6

From A to	Link	Costs
A	Locally	0
B	L1	Inf
D	L3	1
C	L3	3
E	L3	2

From B to	Link	Costs
B	Locally	0
A	L1	Inf
D	L4	2
C	L2	1
E	L4	1

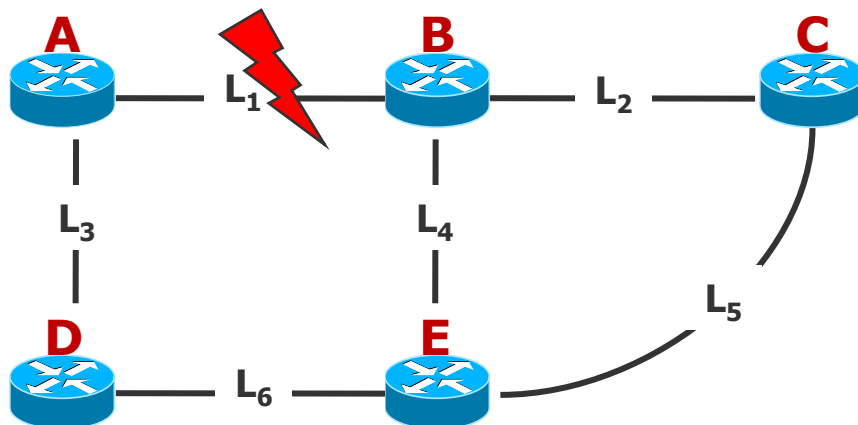



Distance Vector Routing: Connection Loss

From D: (D=0, A=1, B=inf, E=1, C=2)
over link L3 and L6

From C: (C=0, B=1, A=inf, E=1, D=2)
over link L2 and L5

From E: (E=0, B=1, A=inf, D=1, C=1)
over link L4, L5, and L6

From D to	Link	Costs
D	Locally	0
A	L3	1
B	L6	2
E	L6	1
C	L6	2

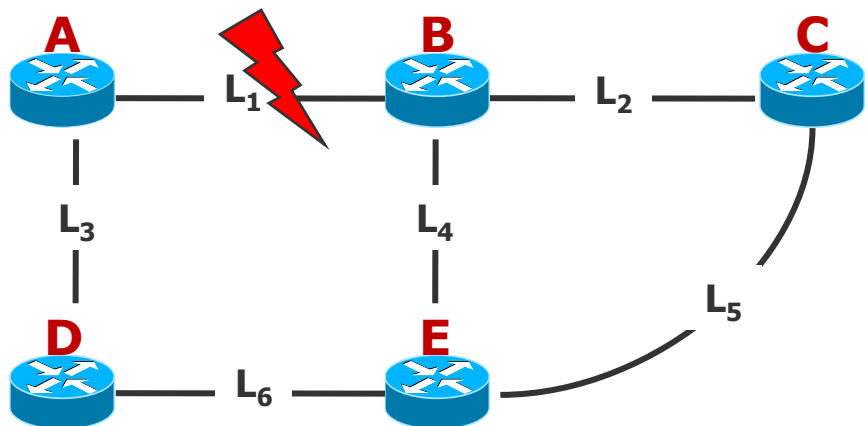

From E to	Link	Costs
E	Locally	0
B	L4	1
A	L6	2
D	L6	1
C	L5	1

Distance Vector Routing: Connection Loss

From A: (A=0, B=inf, D=1, C=3, E=2)
over link L3

From B: (B=0, A=inf, D=2, C=1, E=1)
over link L2 and L4

From D: (D=0, A=1, B=2, E=1, C=2)
over link L3 and L6

From E: (E=0, B=1, A=2, D=1, C=1)
over link L4, L5, and L6

From A to	Link	Costs
A	Locally	0
B	L3	3
D	L3	1
C	L3	3
E	L3	2

From B to	Link	Costs
B	Locally	0
A	L4	3
D	L4	2
C	L2	1
E	L4	1

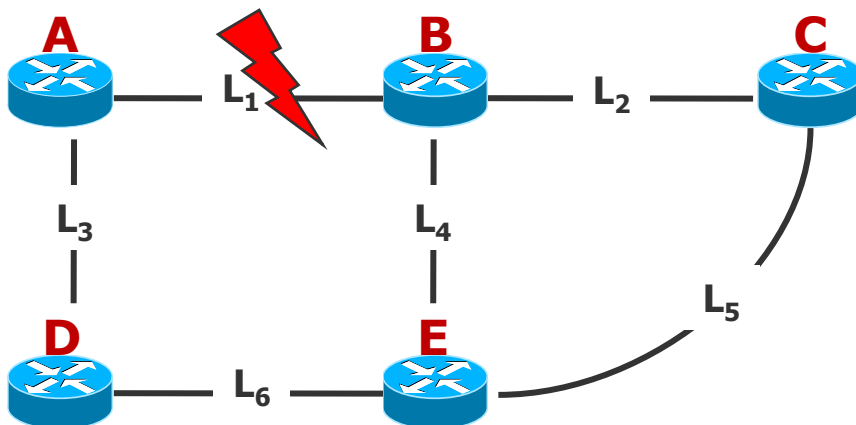

Distance Vector Routing: Connection Loss

From A: (A=0, B=inf, D=1, C=3, E=2)
over link L3

From B: (B=0, A=inf, D=2, C=1, E=1)
over link L2 and L4

From D: (D=0, A=1, B=2, E=1, C=2)
over link L3 and L6

From E: (E=0, B=1, A=2, D=1, C=1)
over link L4, L5, and L6

From C to	Link	Costs
C	Locally	0
B	L2	1
A	L5	3
E	L5	1
D	L5	2

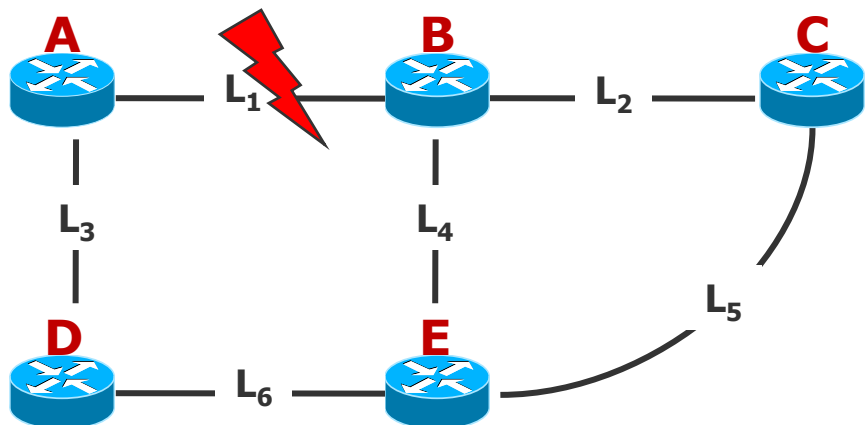

The algorithm terminates, because A, B, and C create and send new vectors, but do not cause further updates in the routing tables.



Distance Vector Routing: The Bouncing Effect

So far: Costs of 1 for each link

Reality: Different costs per link

Example: Link L5 has costs of 10

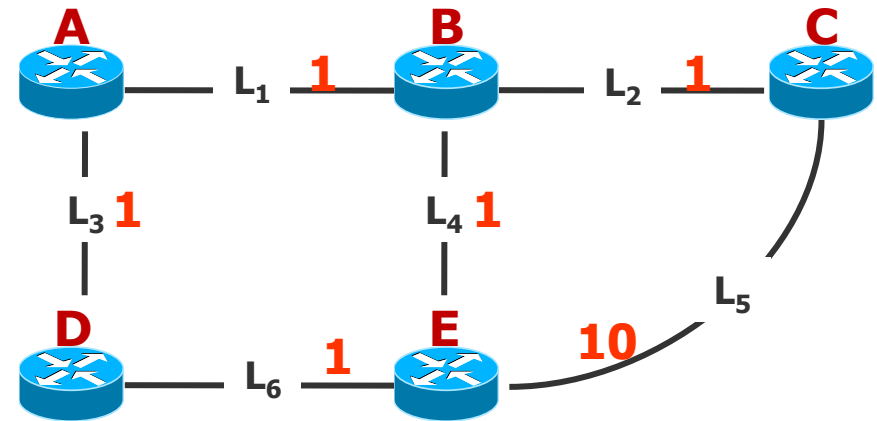

In the following, **only the paths to router C** are examined.

In the case of stable conditions the tables of the other routers have these entries for C.

From	Link	Costs
A to C	L1	2
B to C	L2	1
C to C	Locally	0
D to C	L3	3
E to C	L4	2



Distance Vector Routing: The Bouncing Effect

- Assumption 1: Connection 2 breaks down.
- B detects the failure and sets its costs to inf.

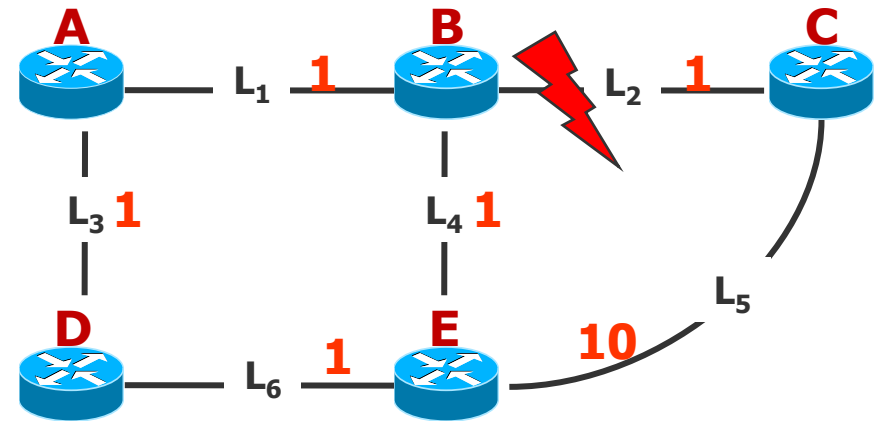

- Temporarily, the following table results:
- Assumption 2: A has sent its vector before B.
 - in case of regular transmission this may happen often

From	Link	Costs
A to C	L1	2
B to C	L2	Inf
C to C	Locally	0
D to C	L3	3
E to C	L4	2



Distance Vector Routing: The Bouncing Effect

- A reports C over link L1 with costs of 2
- Router B adds costs of 1 to link L1 for C
- Value is lower than inf
- Table entry for C is replaced by link L1 and costs of 3
- Passing on the table to A and E
- Message comes over link L1 resp. 4, which A and E are using for C
- Update of A and E

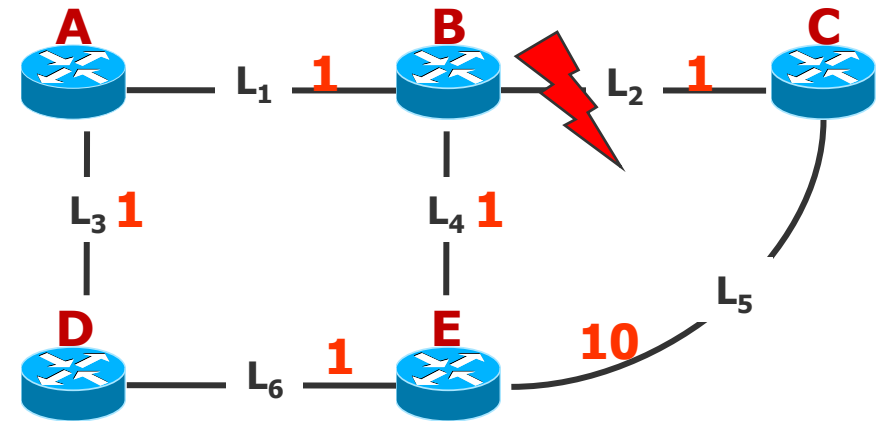

From	Link	Costs
A to C	L1	4
B to C	L1	3
C to C	Locally	0
D to C	L3	3
E to C	L4	4



Distance Vector Routing: The Bouncing Effect

- Routing tables contain a loop!
- Packets from C are bouncing between A and B
- C sends its vector over link L5
- E adds costs of 10 to its own costs of 0
- E ignores the message, because the costs are higher as before
- A and E send vectors
- Update of B and D

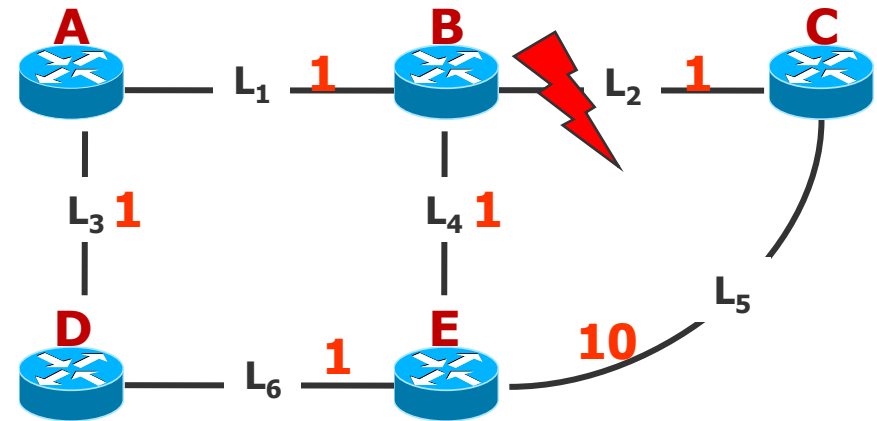

From	Link	Costs
A to C	L1	4
B to C	L1	5
C to C	Locally	0
D to C	L3	5
E to C	L4	4

Distance Vector Routing: The Bouncing Effect

- After several iterations, the following table results:
- Entries depend however on random processes (e.g. on the order of the update messages, the arrival times of the vectors, losses of vectors etc.)

From	Link	Costs
A to C	L1	12
B to C	L4	11
C to C	Locally	0
D to C	L6	11
E to C	L5	10

Distance Vector Routing: Count to Infinity

- Count to Infinity problem:
 - The Distance Vector Routing achieves a correct solution, but possibly many (up to infinite) update steps are necessary.
- Example:
 - Five routers A, B, C, D, and E are connected in a linear fashion, the distance between neighbor routers in each case is 1.

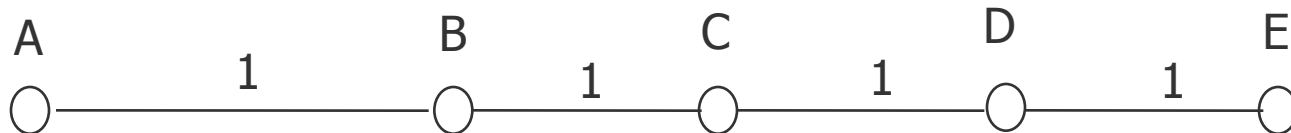

Distance Vector Routing: Count to Infinity

Step 1: Node A is switched off and will be switched on now!



	A	B	C	D	E
to A (A is switched off)		∞	∞	∞	∞
A switched on	1	∞	∞	∞	∞
2. Update	1	2	∞	∞	∞
3. Update	1	2	3	∞	∞
4. Update	1	2	3	4	∞



Distance Vector Routing: Count to Infinity

Step 2: A is switched off

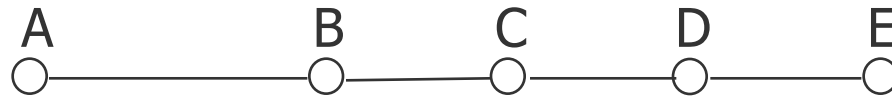

	A	B	C	D	E
A switched off		1	2	3	4
1. Update		3	2	3	4
2. Update		3	4	3	4
3. Update		5	4	5	4
4. Update		5	6	5	6
6. Update		7	8	7	8
		⋮	⋮	⋮	⋮
		⋮	⋮	⋮	⋮
		∞	∞	∞	∞

Distance Vector Routing: Split Horizon Algorithm

- First solution: Split-Horizon Algorithm
- Do not send the distance to X over that link used to transfer packets for X (resp. path is reported as infinity).
- However, it does not work always:
 - Link CD is switched off
 - C hears from A and B that they do not reach D
 - C announces A and B that D is unreachable
 - B announces however to A: D has distance 2
 - A updates and has D with distance 3
 - B updates for D with distance 4
 - Count to Infinity

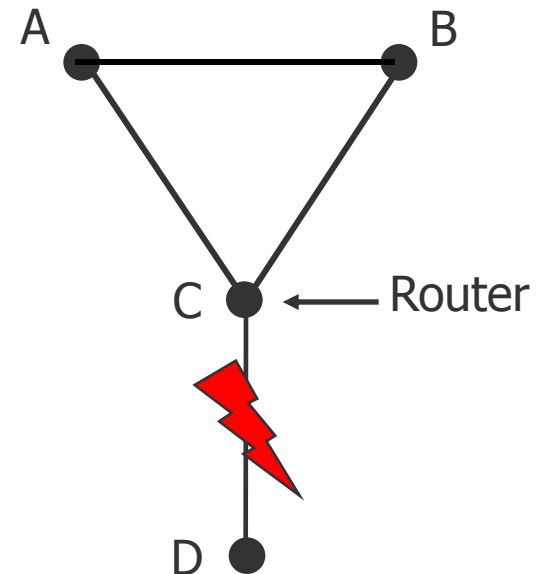

Routing

Routing Information Protocol (RIP)

Routing Information Protocol (RIP)

- Routing Information Protocol (RIP, RFC 1058)
 - Early internal gateway routing protocol used in the Internet
 - Based on the Distance Vector Protocol
 - RIP messages are sent every 30 seconds as UDP datagrams
 - Used metric for the evaluation of the paths is the number of hops
 - The maximum number of hops is limited to 15 \Rightarrow 16 = ∞
 - In a message (only) up to 25 entries of the routing table can be sent
 - Fits good for small systems
- Problems:
 - Slow convergence (duration of minutes)
 - Count to Infinity
 - No considering of subnets
- RIPv2 (RFC 2453):
 - Subnets, CIDR
 - Authentication
 - Multicast, etc.
 - However: max. number of hops is still limited to 15
- RIPng (RFC 2080)
 - IPv6 support
- Internet Gateway Routing Protocol (IGRP)
 - As reaction to the restrictions of RIP Cisco introduced IGRP
 - Extension of the metric, load sharing, more efficient packet format
 - The protocols did not become generally accepted, because they were Cisco specific
 - Replaced by EIGRP (new design)
- Replacement by a Link State Protocol (OSPF)

Information Exchange

- 1.) Exchange of global information locally
(only with neighbors)

Distance Vector Routing

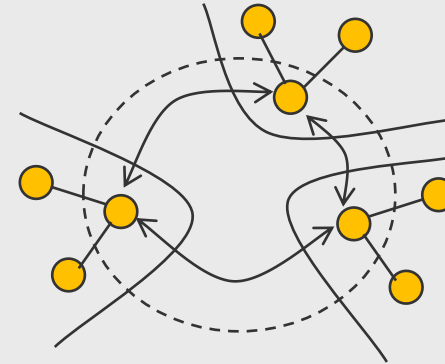

- 2.) Global exchange of local information

Link State Routing

Routers exchange Link State Advertisements (LSA)

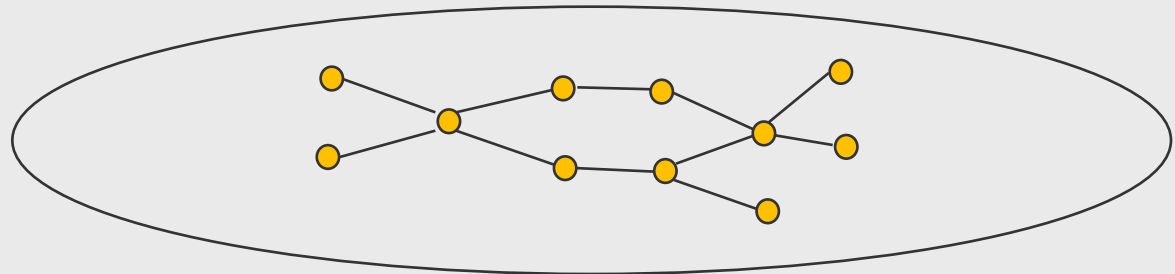



Routing

Link State Routing

Link State Routing

- Every router
 - determines its neighbors and their addresses
 - HELLO packets
 - measures the distances to the neighbors
 - ECHO packets
 - sends these information in a packet to all other routers
 - Link State Advertisement (LSA)
 - computes on the basis of all the received LSAs from other routers the shortest paths to the other routers (e.g. with the Dijkstra algorithm)
- This is repeated regularly.



Link State Routing

- First step:
 - Determination of all neighbor routers
 - Sending of a HELLO message on all links
 - Routers at the other-end answer with their identification
 - If several routers are connected in a (broadcast) network, a new "artificial" node is introduced for simplification

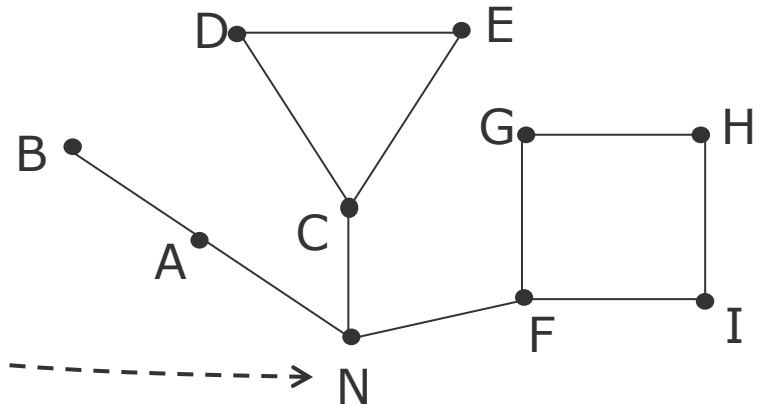
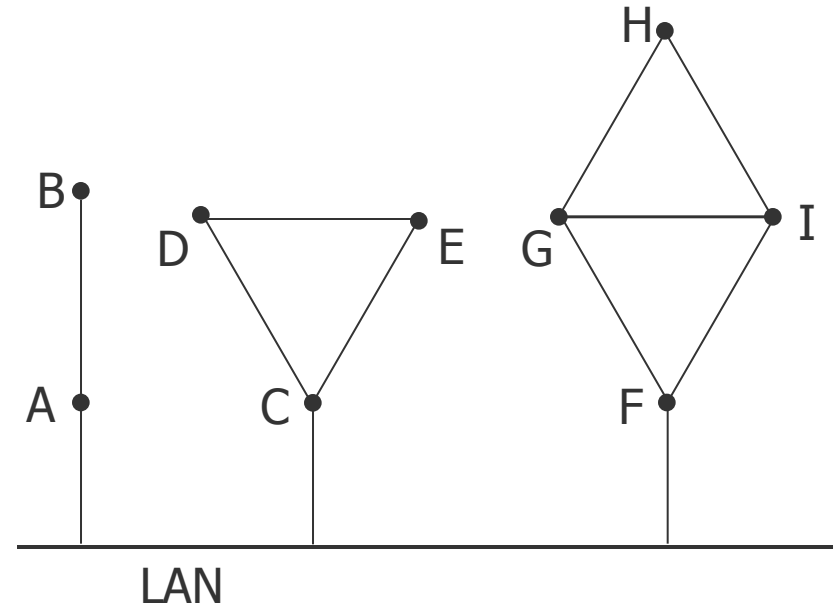

Link State Routing

- Second step: Discovery of link costs
 - Transmission of ECHO messages
 - Routers at the other end answer immediately (measurement of the delay)
 - Inclusion of load leads to the choice of the lowest loaded link
 - Side-effect in having two possible links: the less loaded link is loaded immediately heavily and the other link becomes free, with the next measurement the same happens for the other link, ... (cycling load)

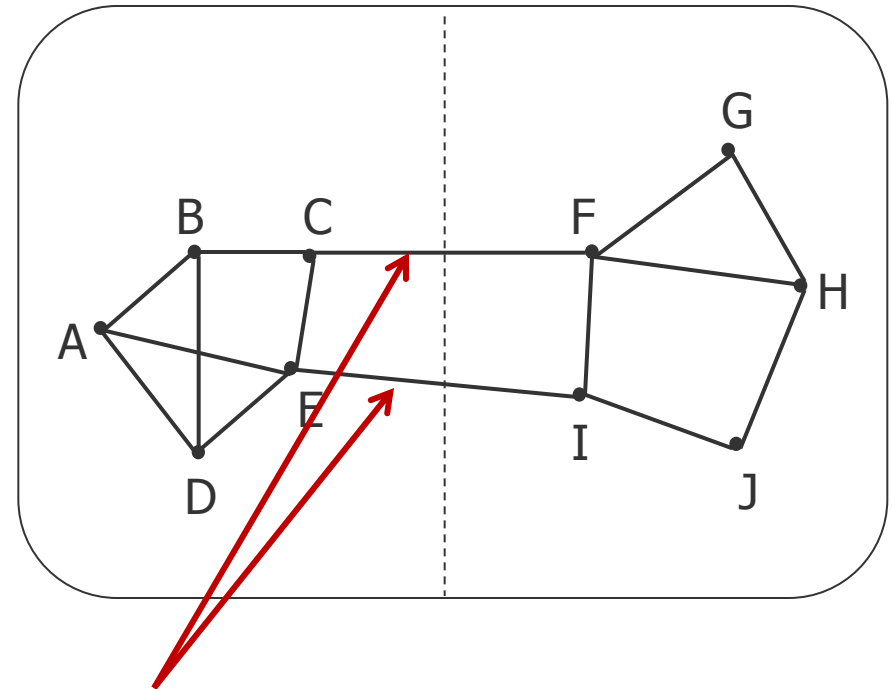

Cycling between both links, because of changing load!



Link State Routing

- Third step: Create link state messages

- Contains list of neighbors with appropriate "link costs" (Delay, queue length, jitter, etc.)
- Messages additionally contain sender identification, sequence number, and age.

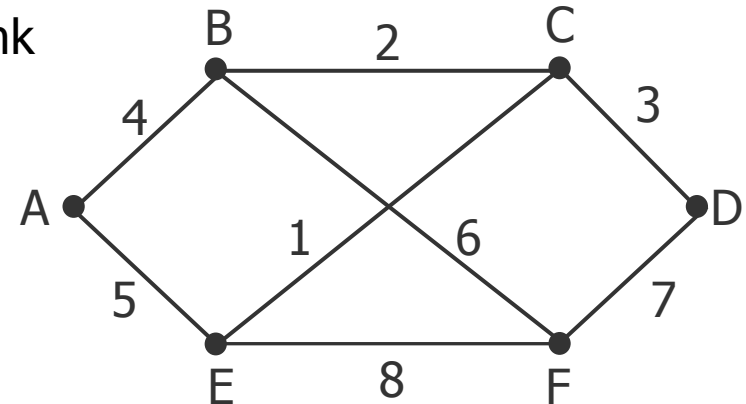

A		B		C		D		E		F	
Seq.No.		Seq.No.		Seq.No.		Seq.No.		Seq.No.		Seq.No.	
Age		Age		Age		Age		Age		Age	
B	4	A	4	B	2	C	3	A	5	B	6
E	5	C	2	D	3	F	7	C	1	D	7
		F	6	E	1			F	8	E	8

Packet Buffer for Router B

- Fourth step: Sending of link state messages
 - Flooding (problem: loops, duplicates, packet losses, etc.)
 - Sequence numbers are counted up, packets with outdated numbers (duplicates) are discarded
 - Every router reduces the "age" by one, with zero a packet is discarded
 - Each router confirms the arrival of a link state packet to the sending router

Data structure of router B

- Flags are for the lines of router B

Source	Seq.No.	Age	Transmission flags			Confirmation flags			Data
			A	C	F	A	C	F	
A	21	60	0	1	1	1	0	0	
F	21	60	1	1	0	0	0	1	
E	21	59	0	1	0	1	0	1	
C	20	60	1	0	1	0	1	0	
D	21	59	1	0	0	0	1	1	



Packet Buffer for Router B

- Link state message from A arrives directly, therefore Age=60, Seq.No.=21
- Message is sent to C and F, and confirmed for A
- Message of F must be forwarded to A and C, and be confirmed for F
- Message of E came twice (over EAB and EFB) therefore only forwarding to C, confirmation for A and F

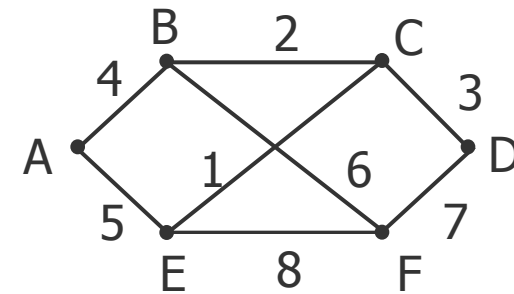

Source	Seq.No.	Age	Transmission flags			Confirmation flags			Data
			A	C	F	A	C	F	
A	21	60	0	1	1	1	0	0	
F	21	60	1	1	0	0	0	1	
E	21	59	0	1	0	1	0	1	
C	20	60	1	0	1	0	1	0	
D	21	59	1	0	0	0	1	1	

Route Enquiry

- Fifth step: Decision on best routes
 - Router collects link state information from all other routers
 - A path graph for the entire sub-network is determined
 - Local execution of e.g. the Dijkstra algorithm for the determination of the optimal route
 - Results are written into the routing table
- Problems:
 - With n routers and m neighbors, $n \cdot m$ table entries are necessary
 - In the case of router failures, the graphs of all routers are outdated
 - Extremely susceptible to attacks



Routing

Hierarchical Routing

Routing Tables

- Problem: extensive routing tables
 - ➔ hierarchical routing
- Large tables require too much memory, CPU time, transmission capacity for link state messages, etc.
 - ➔ virtual division of the network (Regions)

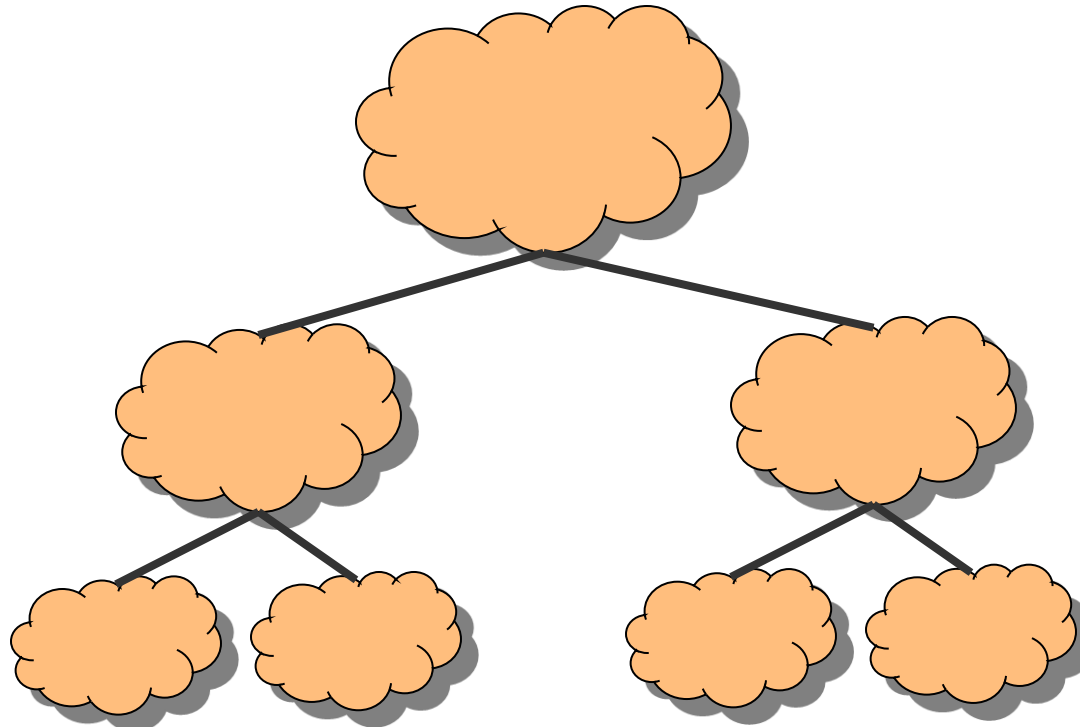

Hierarchical Routing

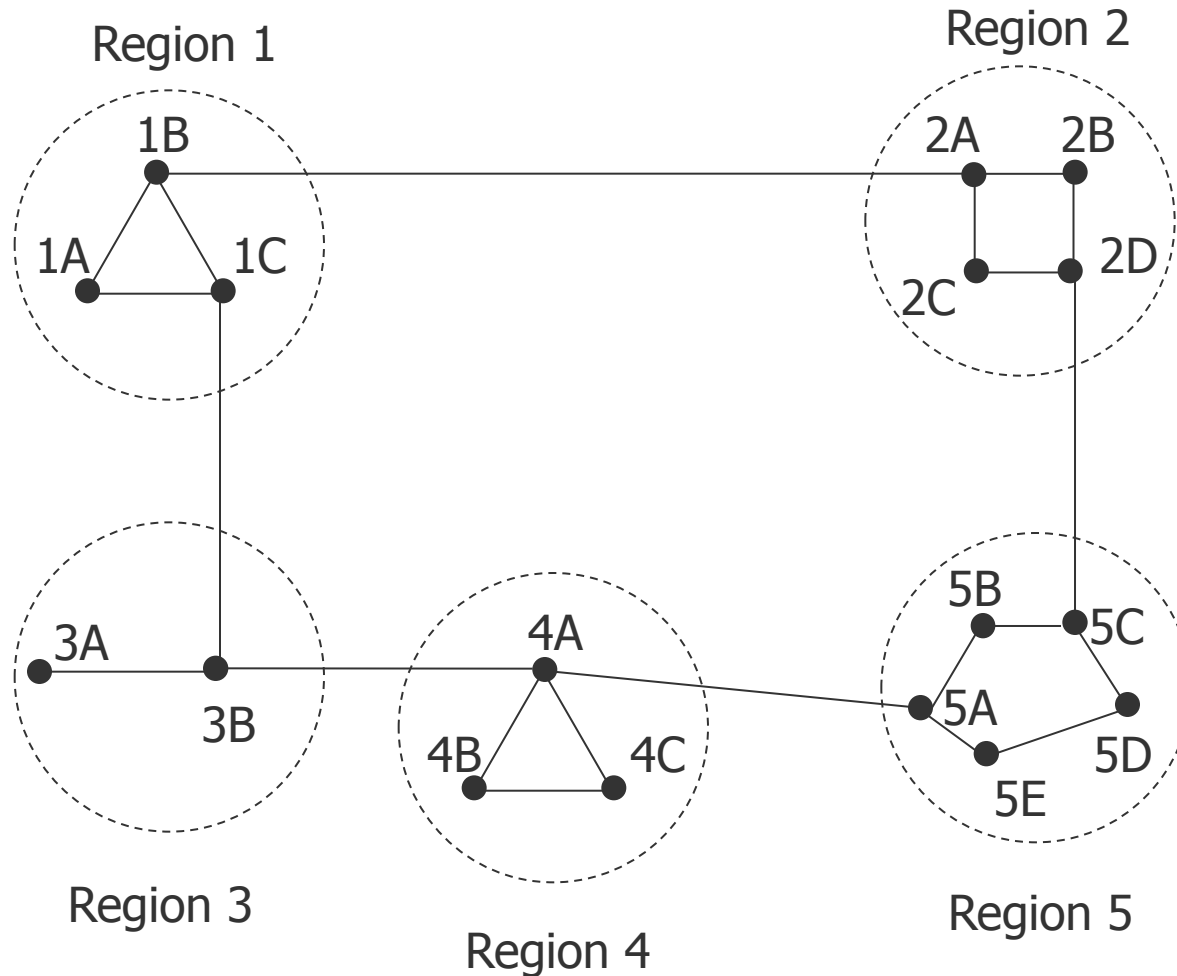

Hierarchical Routing

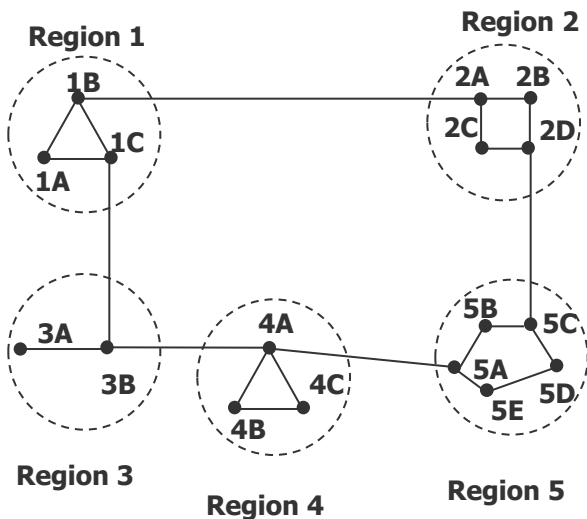

Disadvantage:
Possibly increasing path length

Full routing table for 1A

Dest.	Link to	Hops
1A	-	-
1B	1B	1
1C	1C	1
2A	1B	2
2B	1B	3
2C	1B	3
2D	1B	4
3A	1C	3
3B	1C	2
4A	1C	3
4B	1C	4
4C	1C	4
5A	1C	4
5B	1C	5
5C	1B	5
5D	1C	6
5E	1C	5

Hierarchical routing table for 1A

Dest.	Link to	Hops
1A	-	-
1B	1B	1
1C	1C	1
2	1B	2
3	1C	2
4	1C	3
5	1C	4



Routing / Interior

Open Shortest Path First (OSPF)

Intermediate System to Intermediate System (IS-IS)

Open Shortest Path First (OSPF)

- Open Shortest Path First (OSPF)
 - 1990 standardized by IETF (RFC 1247)
 - Current versions:
 - OSPF version 2 (RFC 2328) for IPv4
 - OSPF version 3 (RFC 5340) with IPv6 support
 - Open protocol (not manufacturer specific)
 - Supports a multiplicity of metrics (distance, delay, etc.)
 - Dynamic algorithm for fast adjustment to changing conditions in the network
 - Load sharing between redundant links
 - Supports hierarchical systems
 - Contains security mechanisms to protect routers from wrong routing information or attacks
 - Three types of connections are supported:
 - Point-to-point links between routers
 - Broadcast networks (mostly LANs)
 - Multi-access networks without broadcasting (e.g. packet switching WANs)

Open Shortest Path First (OSPF)

- Autonomous Systems (AS)
 - The Internet is divided into autonomous systems (AS, 32 bit ID, was 16 bit)
 - Each autonomous system has a **backbone**, which connects all parts of the AS
 - Large autonomous systems are divided into **areas**
- Area of an AS
 - Within an area every router has the **same link state database** and implements the **same algorithm** for determination of the shortest path
 - Every router, which belongs to **two or more areas**, is part of the backbone
 - A router, which connects two areas, needs the link state databases from both areas

Open Shortest Path First (OSPF)

- OSPF distinguishes four router classes
 - For reducing the extent of routing tables
- Classes of routers
 - Internal routers, which only belong to one area
 - Area routers at the border of areas, which connect two or more areas
 - Backbone routers, which are placed at the backbone
 - AS border routers, which mediate between several autonomous systems

Open Shortest Path First (OSPF)

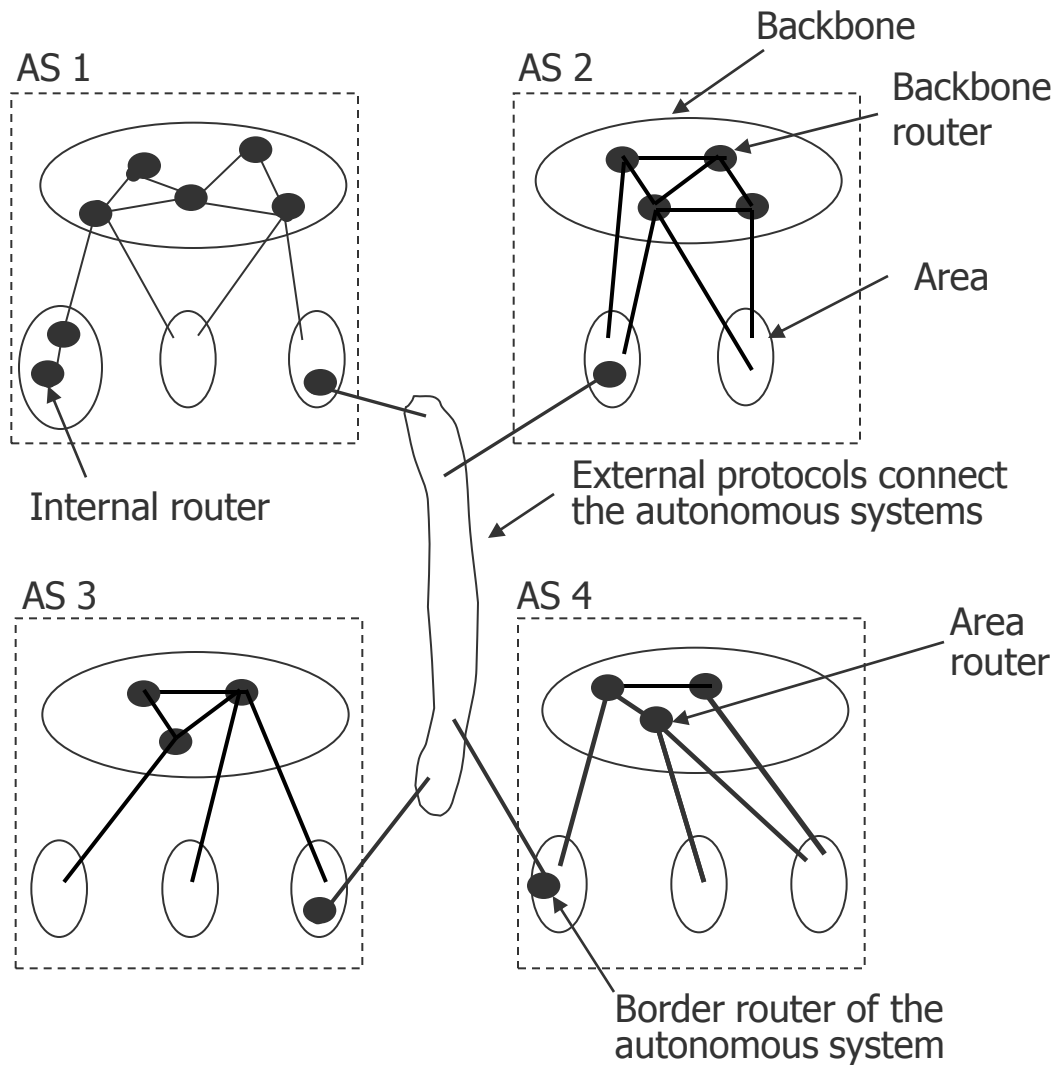

Relationship between autonomous systems, backbones, and areas in OSPF

Intermediate System to Intermediate System (IS-IS)

- Standardized in the context of OSI for the connectionless layer 3 protocol
 - Republished by IETF as RFC 1142 (however sometimes also cited as IS-IS=0 ...)
- Link-state, very similar to OSPF, based on Dijkstra
- Neutral to layer 3 protocol (OSPF routes IP, originally v4)
 - Thus IPv6 got faster support by IS-IS
- Routers also build a map of the network, calculate shortest path
- Lower overhead compared to OSPF, better scalability
 - Often used by network operators with many routers

Routing / Exterior

Border Gateway Protocol (BGP)

Border Gateway Protocol (BGP)

- Goal difference between internal and external protocols
 - Interior gateway protocols are designed for **efficiency**
 - Find the best way to the destination host
 - Exterior gateway protocols have to consider **policies**
 - Political, economical, ...
- Border Gateway Protocol (BGP)
 - BGPv4 (RFC 4271, RFC 4274, RFC 4276)
 - De-facto standard inter-AS routing protocol in the Internet
- An external routing protocol
 - Variant of the Distance Vector Protocol: not the costs of a transmission path are being monitored and exchanged, but the *complete description of paths* (Path Vector Protocol)
 - Considers security and other rules (Routing Policies)
 - Communicates the neighbor routers the whole path which is to be used (deterministically)
 - Uses TCP for data exchange (port 179)

Border Gateway Protocol (BGP)

Assumption:

F uses FGCD to reach D

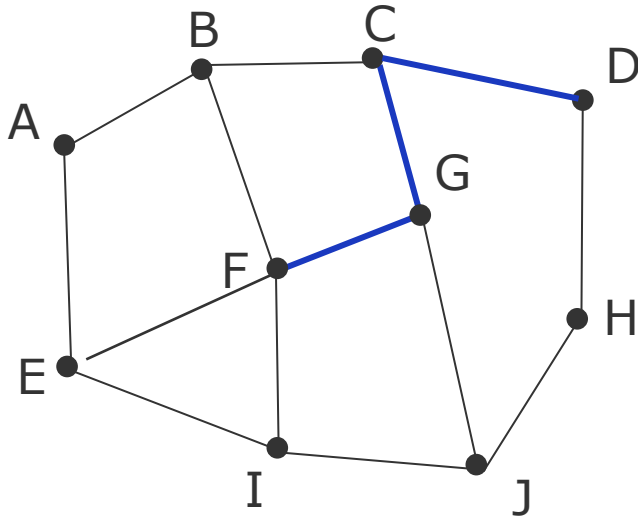

Information sent to F

F receives the following information about D from its neighbors:

from B: "I use BCD"

from G: "I use GCD"

from I: "I use IFGCD"

from E: "I use EFGCD"

F searches for the optimal route

- Paths of I and E are directly discarded, because they cross F
- B and G are possible options
- Application of Policies
- Routes, which violate policies, are being set to infinity

BGP Example:

Dest. Net.	Next-Hop	Path	...	(see RFC 4271)
141.3.0.0/16	195.221.222.254	5409 1275 553		



Size of BGP routing tables (bgp.potaroo.net)

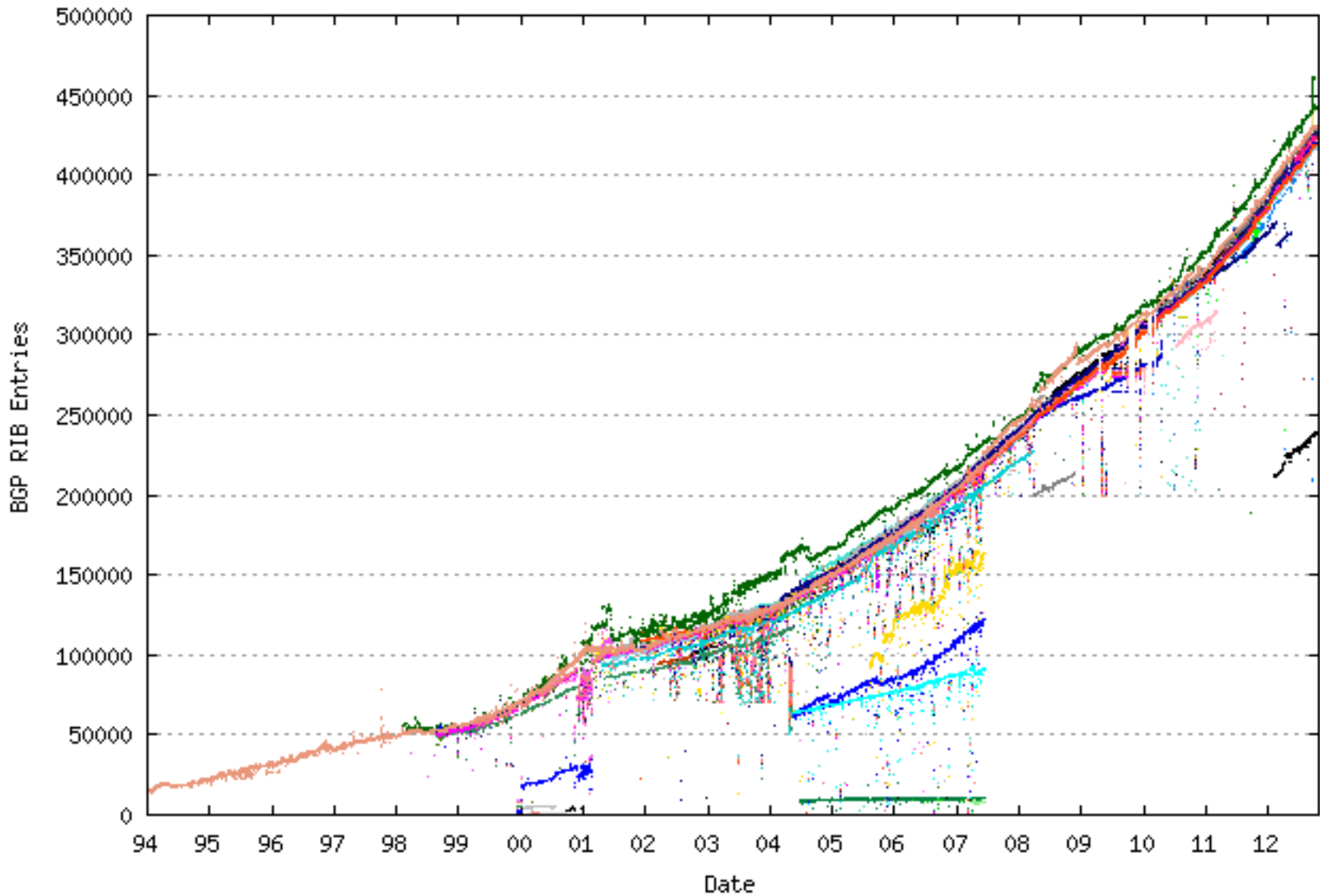

Number of assigned ASs (bgp.potaroo.net)

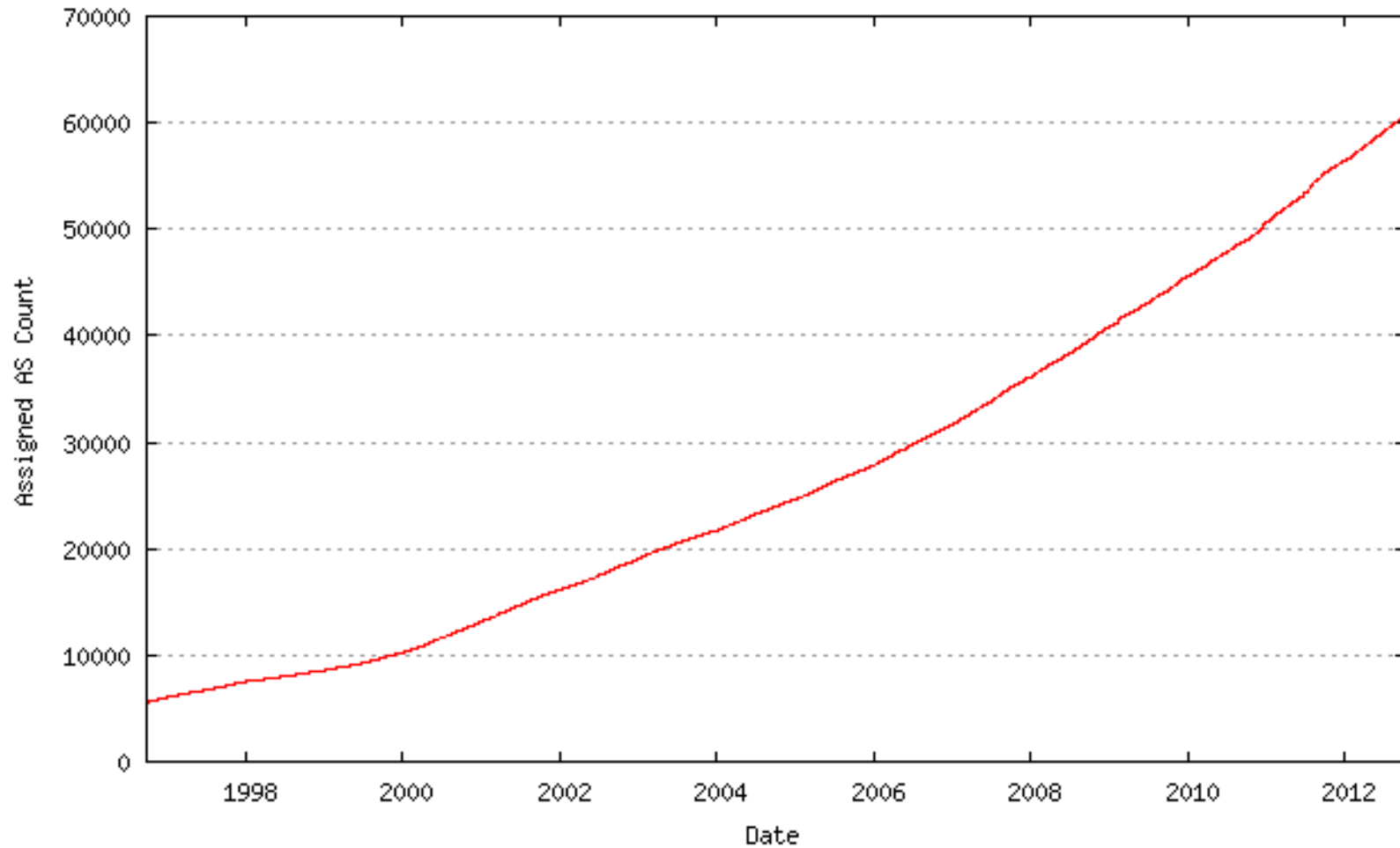

BGP is crucial to the Internet

- Many issues / problems
 - Stability, routing table growth, load balancing in multi-homed networks, hijacking
 - ...
- Suggested reading
 - Delayed Internet Routing Convergence
 - 2-year measurements of BGP convergence
 - It takes between 3 and 15 minutes for paths to converge
 - <http://conferences.sigcomm.org/sigcomm/2000/conf/paper/sigcomm2000-5-2.pdf>
 - Analysis of BGP Update Burst during Slammer Attack
 - Consequences of the slammer worm on BGP in 2003
 - Shows nicely the effect of small ASs on the global update traffic
 - Two small ASs that contribute only to 0.25% of routing table entries caused 6% of all BGP update messages
 - http://irl.cs.ucla.edu/papers/mohit_iwdc03.pdf
 - Measurement of Highly Active Prefixes in BGP
 - Examines the stability of routes and shows that very few prefixes contribute to the majority of BGP update traffic
 - <http://www.cs.ucla.edu/~lixia/papers/05Globcom.pdf>

Summary

- TCP/IP reference model defines only one protocol for layer 3
 - The Internet Protocol (IP)
 - Connectionless transmission, data packets are forwarded hop-by-hop
 - Supported by routing protocols to determine the best way to a destination
 - ICMP for exchange of control messages
 - ARP for mapping of IP addresses to MAC addresses
- But, there are several problems with the "current" IPv4
 - address space, security, mobility, quality of service, ...
 - Large number of additional protocols to deal with these problems: network address translation, IPsec, Mobile IP, IntServ, DiffServ, MPLS, ...
- Successor IPv6 could deal with (some of) the problems, but when/where/to what extent will it come?
 - See e.g. <http://resources.potaroo.net/iso3166/v6cc.html> for current usage