

Telematics

Chapter 2: Introduction

Univ.-Prof. Dr.-Ing. Jochen H. Schiller
 Computer Systems and Telematics (CST)
 Institute of Computer Science
 Freie Universität Berlin
<http://cst.mi.fu-berlin.de>

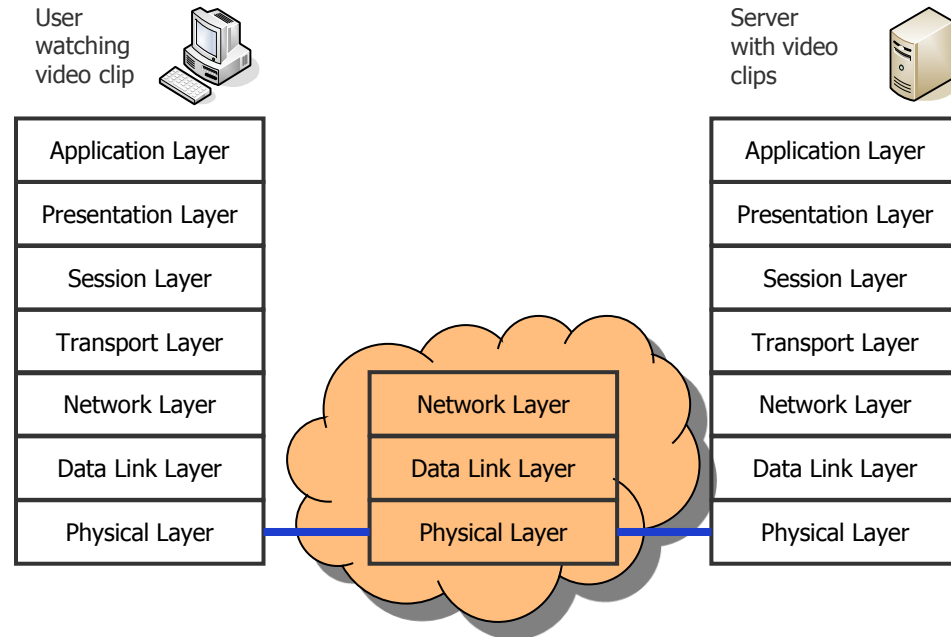

Contents

- Data Communication
- What is Digital Data?
- Why Data Communication?
- Networking Principles
- Non-technical Aspects of Networking
- Communication Protocols
- The ISO/OSI Reference Model
- The TCP/IP Reference Model
- OSI vs. TCP/IP
- Standardization
- Evolution of Computer Networks
- Classification of Computer Networks



Data Communication

Data Communication

Data Communication

Data communication is the **processing** and the **transport** of digital data over connections between computers and/or other devices.
Data communication comprises two topical areas.



```
1010011100
1101011100
1101011100
1101010100
0001110101
1110001...
```



1. Computer Networks

- How to connect several computers?
- Which media can be used for data transport?
- How to represent digital data on the medium?
- How to coordinate the access of several computers to the medium?

2. Communication Protocols

- Design of uniform data units for transfer
- How to achieve a reliable and efficient transfer?

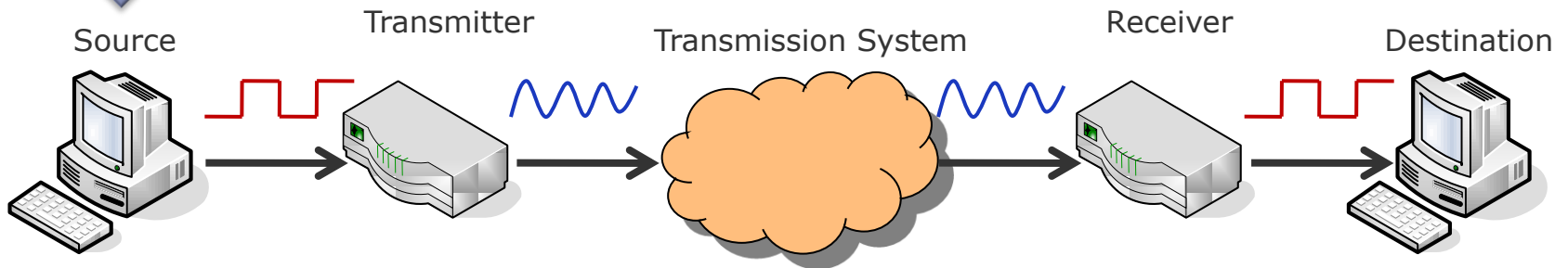



Signals, Data, and Information

The Term of Data

- Data (universal)
 - Representation of facts, concepts, and statements in a formal way which is suitable for communication, interpretation, and processing by human beings or technical means.
- Examples for data representation
 - Spoken language
 - Sign language
 - Written language

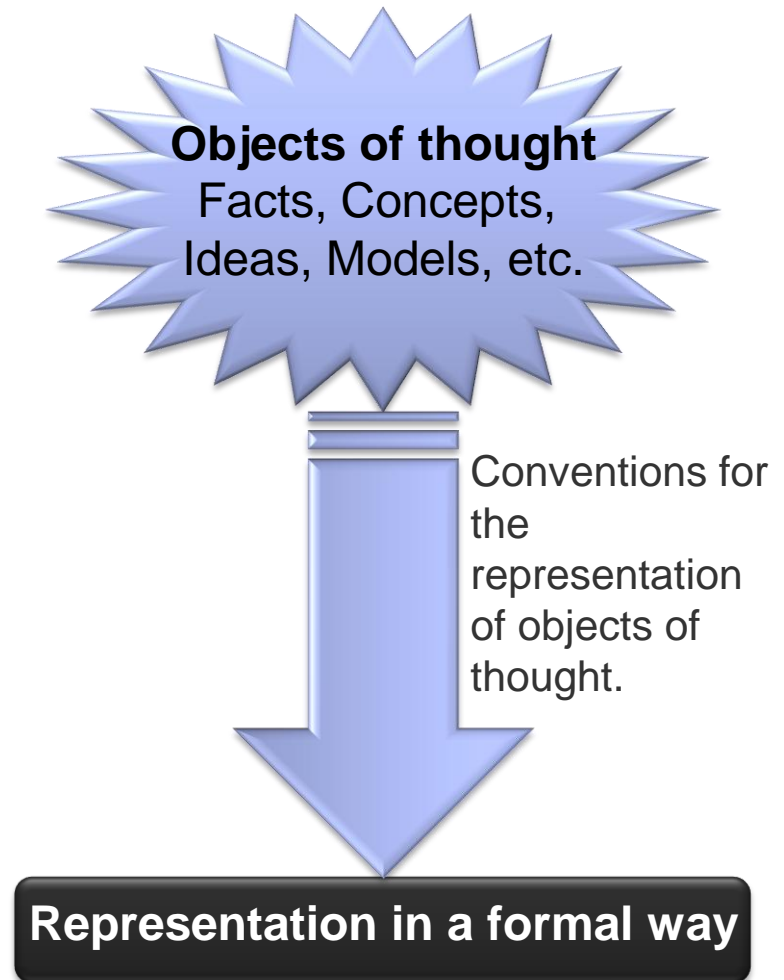

The Term of Information

- Information

- Generally, information is whatever is capable of causing a **human mind** to change its opinion about the current state of the real world. Formally, and especially in science and engineering, information is whatever **contributes to a reduction in the uncertainty of the state of a system**; in this case, uncertainty is usually expressed in an **objectively measurable** form.

(Oxford Reference Online)

- The communication or reception of knowledge or intelligence
- Attention: The notion of “Information” is defined for humans
- Information has to be distinguished from any **medium** that is capable of **carrying** it
- Humans and machines can handle **data**, however only humans can handle **information**

The Term of Signal

- Signal
 - A signal is the physical representation of data by **spatial** or **timely variation** of physical characteristics
 - The variable parameter that contains information and by which information is transmitted in an electronic system or circuit.
 - The signal is often a **voltage source** in which the **amplitude**, **frequency**, and **waveform** can be varied.
 - Signal is the real physical representation of an abstract representation

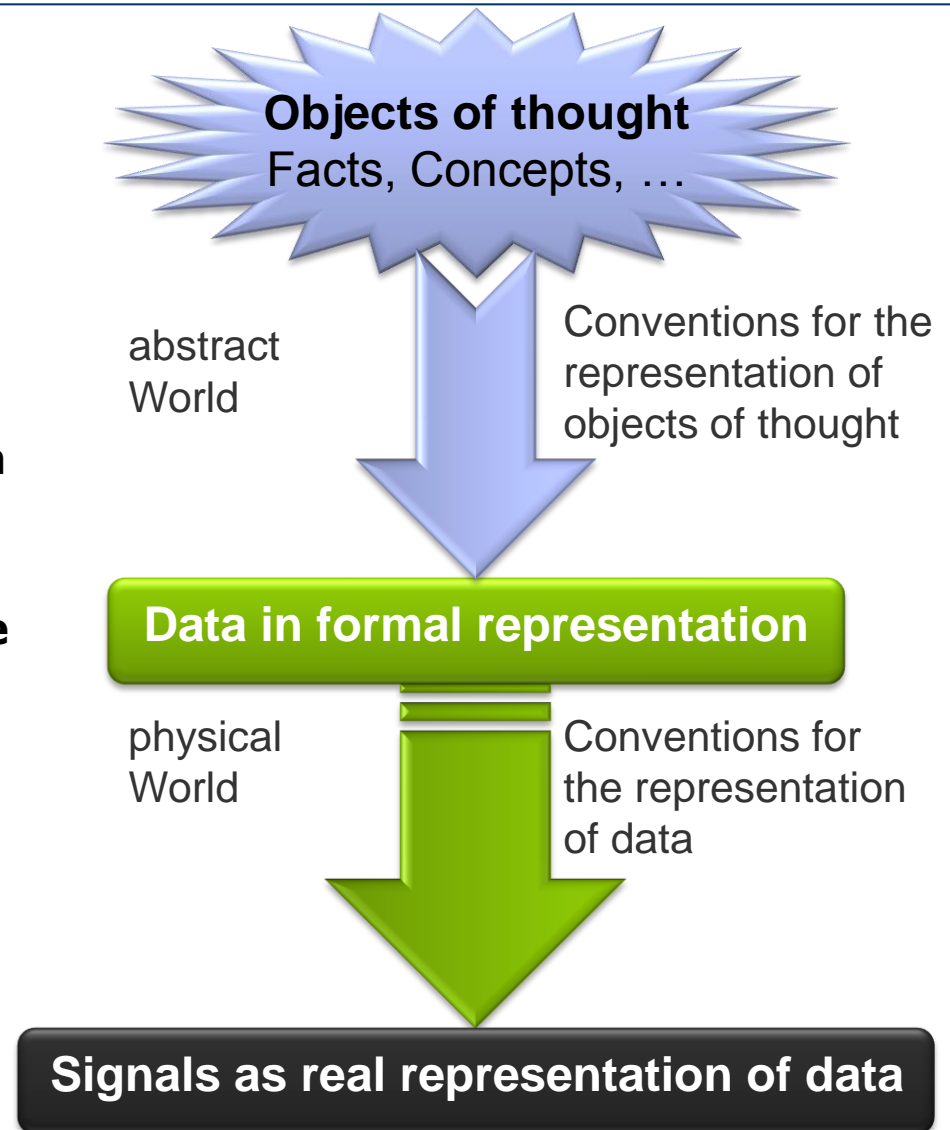

Data vs. Signals

- The border between Data and Signal

- The terms "Data" and "Signal" are often used interchangeably or as synonyms, since storing, transmission, processing of data is done in physical representation as "Signals".
- Every specific representation of data is bound to a particular representation of signals.
- Thus, the conceptual difference between both terms is often not evident.



- Examples:

- Sounds of a language (Data) during speaking are acoustic waves (Signals)
- Printed letters on paper are optical signals of abstract characters (Data)

Communications Engineering vs. Telematics

● Communications Engineering

- Deals primarily with physical-technological issues of ICT
- Term of "Signal" is important
- Term of "Information" is correlated with the term of "Signal"

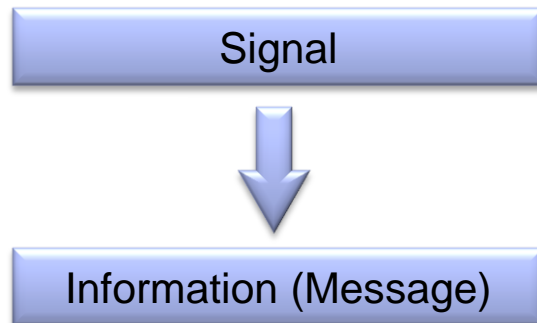

● Telematics

- The term of "Data" is in focus
- The term of "Signal" is restricted on transmission of communication systems
- Model with 2-steps of abstraction from "Signals" to "Information"

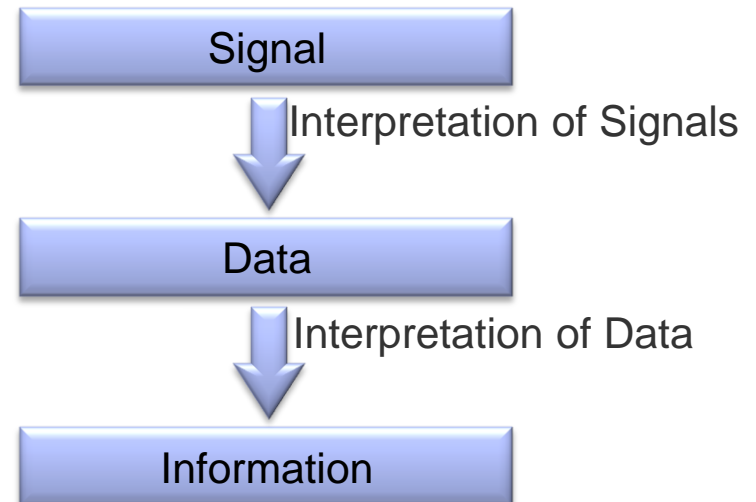



Why Data Communication?

Evolution of Data Communication

- Sharing resources saves costs:
 - By communication, one can access resources of other parties
 - ➔ this reduces the costs (compared to buying own resources)
 - Several institutions can share expensive resources which cannot be completely utilized by a single institution
 - Requirements:
 - Efficient mechanisms for data exchange between components of a distributed system
 - Mechanisms for efficient interaction
- The “driving power” for the enormous increase of data communication:
 - Decreasing costs for hardware...
 - ... while the computing power increases.

➔ **How do several communication partners interact?**



Networking Principles

Communication Peers

- Unicast: Two communication peers communicate over a Point-to-Point connection.
- Multicast: One sender communicates to several receivers, which are known.
- Broadcast: One sender transmits to all other peers.
 - Typically the other peers are (partially) unknown.
- Others: Anycast, Geocast, etc.

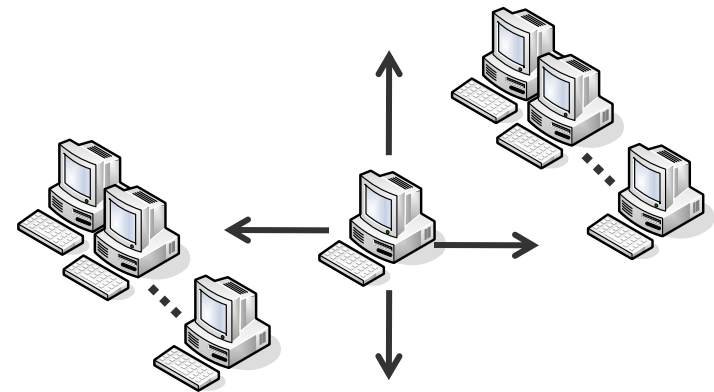
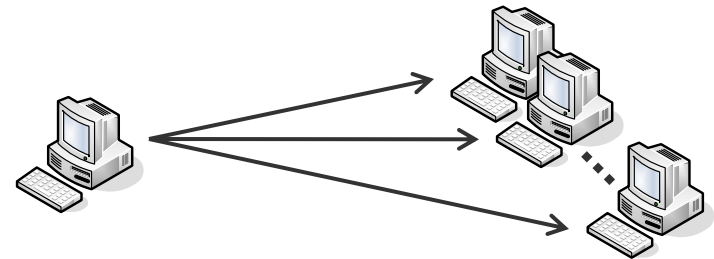

Transmission Principles

- Serial Transmission

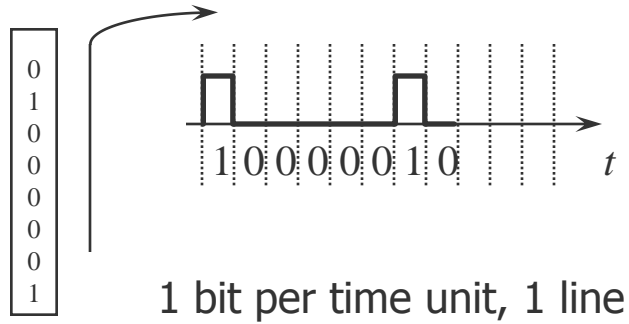

- Parallel Transmission

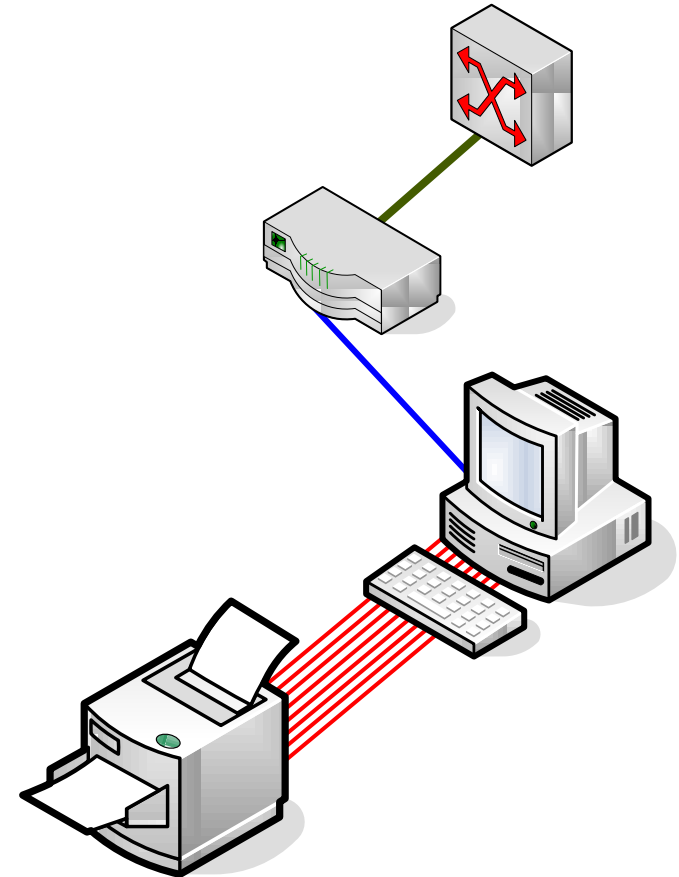
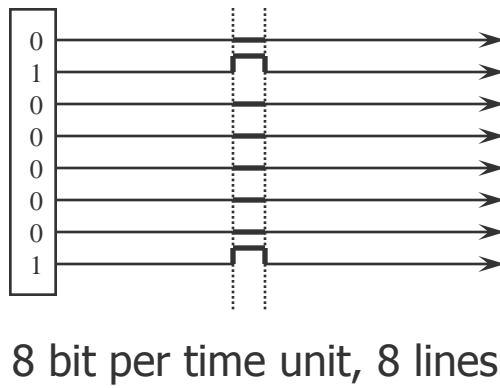

Transmission Principles

- **Asynchronous Transmission:** Transmission in which each block/frame/character is individually synchronized

- Example on Physical Layer

- Data transmitted as **one character** at a time → Character set → ASCII
- Synchronization must only be maintained for each character

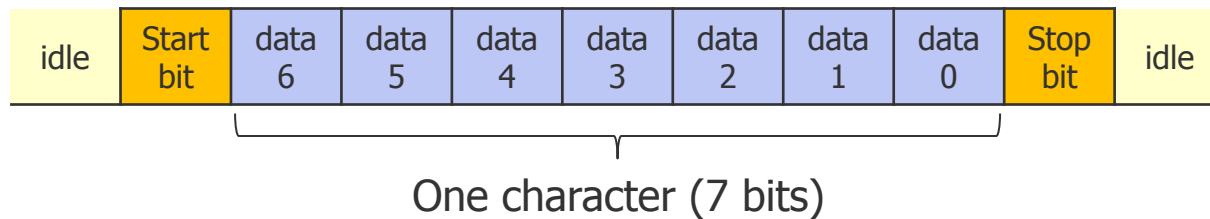

- Example on Data Link Layer (HDLC...)

- Blocks of bits (frame)

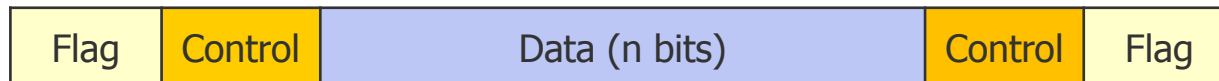

- **Synchronous Transmission:** Transmission in which the time of occurrence of each signal representing a bit is related to a fixed time frame

- Example GSM, ISDN...

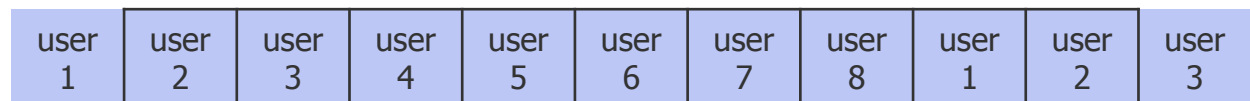

Transmission Principles: ASCII Table

- American Standard Code for Information Interchange (ASCII)
 - Character encoding based on English
 - Printable, non-printable, and control characters

Dec	Hex	Oct	Char	Dec	Hex	Oct	Char	Dec	Hex	Oct	Char	Dec	Hex	Oct	Char
0	0	0		32	20	40	[space]	64	40	100	@	96	60	140	`
1	1	1		33	21	41	!	65	41	101	A	97	61	141	a
2	2	2		34	22	42	"	66	42	102	B	98	62	142	b
3	3	3		35	23	43	#	67	43	103	C	99	63	143	c
4	4	4		36	24	44	\$	68	44	104	D	100	64	144	d
5	5	5		37	25	45	%	69	45	105	E	101	65	145	e
6	6	6		38	26	46	&	70	46	106	F	102	66	146	f
7	7	7		39	27	47	'	71	47	107	G	103	67	147	g
8	8	10		40	28	50	(72	48	110	H	104	68	150	h
9	9	11		41	29	51)	73	49	111	I	105	69	151	i
10	A	12		42	2A	52	*	74	4A	112	J	106	6A	152	j
11	B	13		43	2B	53	+	75	4B	113	K	107	6B	153	k
12	C	14		44	2C	54	,	76	4C	114	L	108	6C	154	l
13	D	15		45	2D	55	-	77	4D	115	M	109	6D	155	m
14	E	16		46	2E	56	.	78	4E	116	N	110	6E	156	n
15	F	17		47	2F	57	/	79	4F	117	O	111	6F	157	o
16	10	20		48	30	60	0	80	50	120	P	112	70	160	p
17	11	21		49	31	61	1	81	51	121	Q	113	71	161	q
18	12	22		50	32	62	2	82	52	122	R	114	72	162	r
19	13	23		51	33	63	3	83	53	123	S	115	73	163	s
20	14	24		52	34	64	4	84	54	124	T	116	74	164	t
21	15	25		53	35	65	5	85	55	125	U	117	75	165	u
22	16	26		54	36	66	6	86	56	126	V	118	76	166	v
23	17	27		55	37	67	7	87	57	127	W	119	77	167	w
24	18	30		56	38	70	8	88	58	130	X	120	78	170	x
25	19	31		57	39	71	9	89	59	131	Y	121	79	171	y
26	1A	32		58	3A	72	:	90	5A	132	Z	122	7A	172	z
27	1B	33		59	3B	73	;	91	5B	133	[123	7B	173	{
28	1C	34		60	3C	74	<	92	5C	134	\	124	7C	174	
29	1D	35		61	3D	75	=	93	5D	135]	125	7D	175	}
30	1E	36		62	3E	76	>	94	5E	136	^	126	7E	176	~
31	1F	37		63	3F	77	?	95	5F	137	_	127	7F	177	

Connection Properties

Simplex

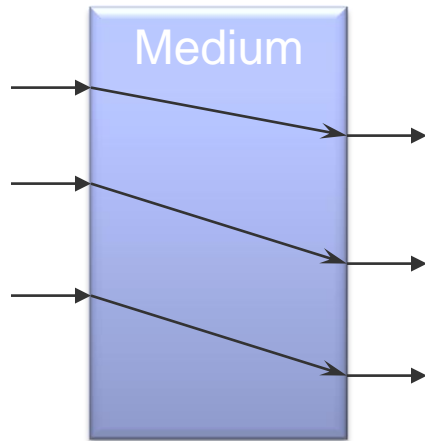

- Fire detector
- Sensors
- Pager



Duplex

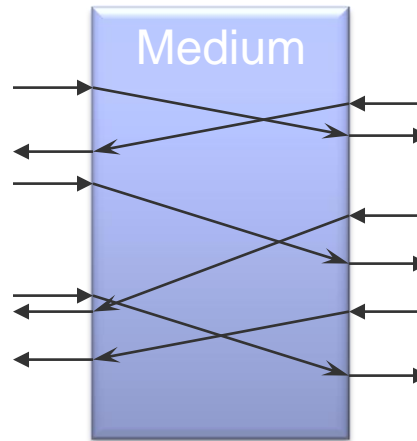

- Telephone



Half-duplex

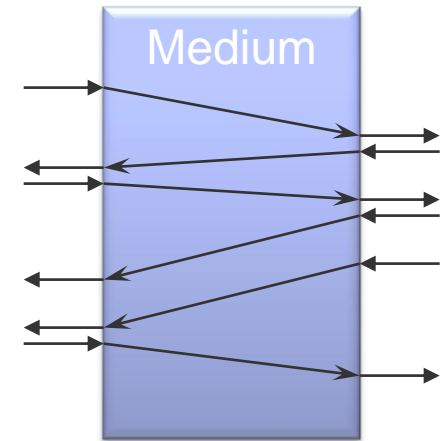

- Walkie-Talkie
- partly GSM-Voice connections



Multiplexing Basics

- Multiplexing
 - Combining multiple data channels into a single data channel at the source
- Demultiplexing
 - Separating multiplexed data channels at the destination

- Multiplexing can be implemented on different levels in a communication, i.e., on any of the OSI layers!

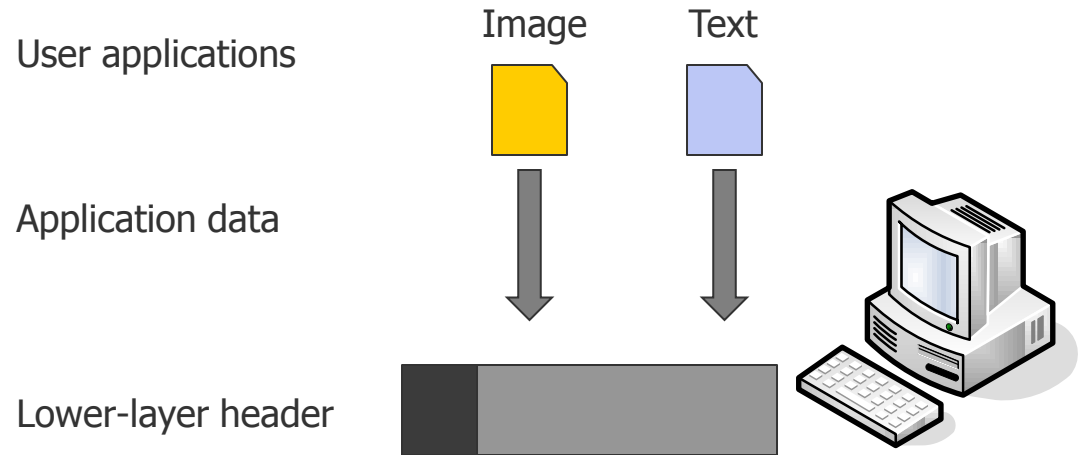
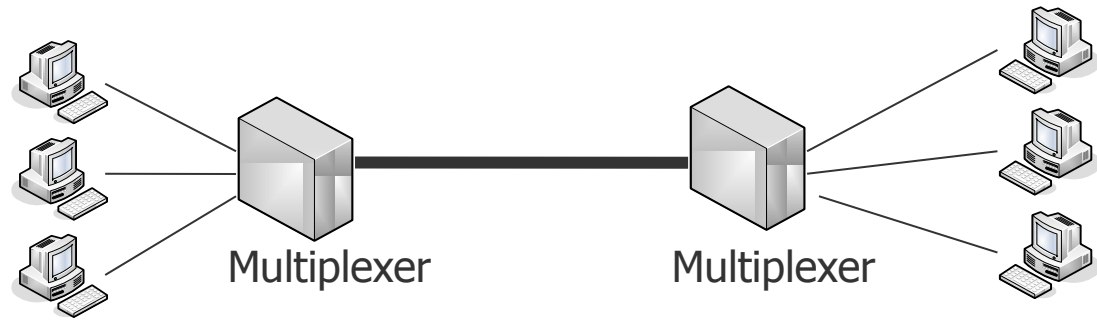

Quality

- Besides the functional aspects and usability, the following quality requirements are important:
 - Technical Performance
 - Required transmission performance, delay, jitter, throughput, data rate, etc.
 - Costs
 - Investment costs, cost of operation, etc.
 - Reliability
 - Fault tolerance, system stability, immunity, availability, etc.
 - Security and Protection
 - Eavesdropping, authentication, denial of service, etc.

Quality: Technical Performance

- Delay

- Measured in seconds [s]

$$d_1 = t'_1 - t_1$$

- Round-trip-time (RTT)

- Measured in seconds [s]

$$r_1 = t_2 - t_1$$

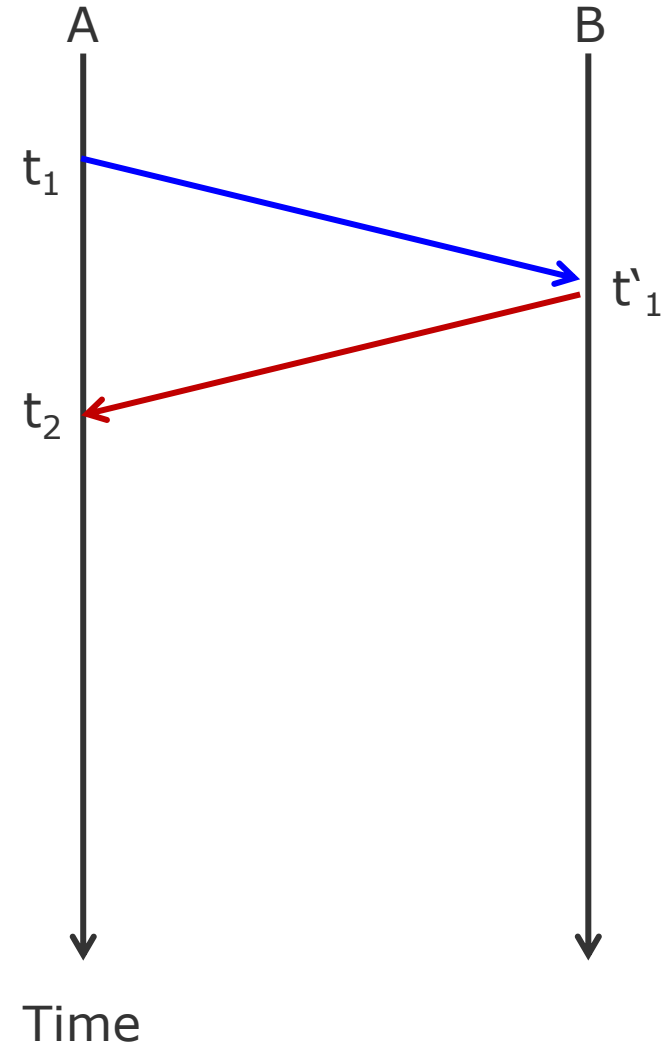

Quality: Technical Performance

- Jitter is the fluctuation between successive arrivals

- Measured in seconds [s]
- First calculate delay as

$$d_1 = t'_1 - t_1$$

$$d_2 = t'_2 - t_2$$

$$d_i = t'_i - t_i$$

- Afterwards derive the jitter

$$j_1 = d_2 - d_1$$

$$j_2 = d_3 - d_2$$

$$j_i = d_{i+1} - d_i$$

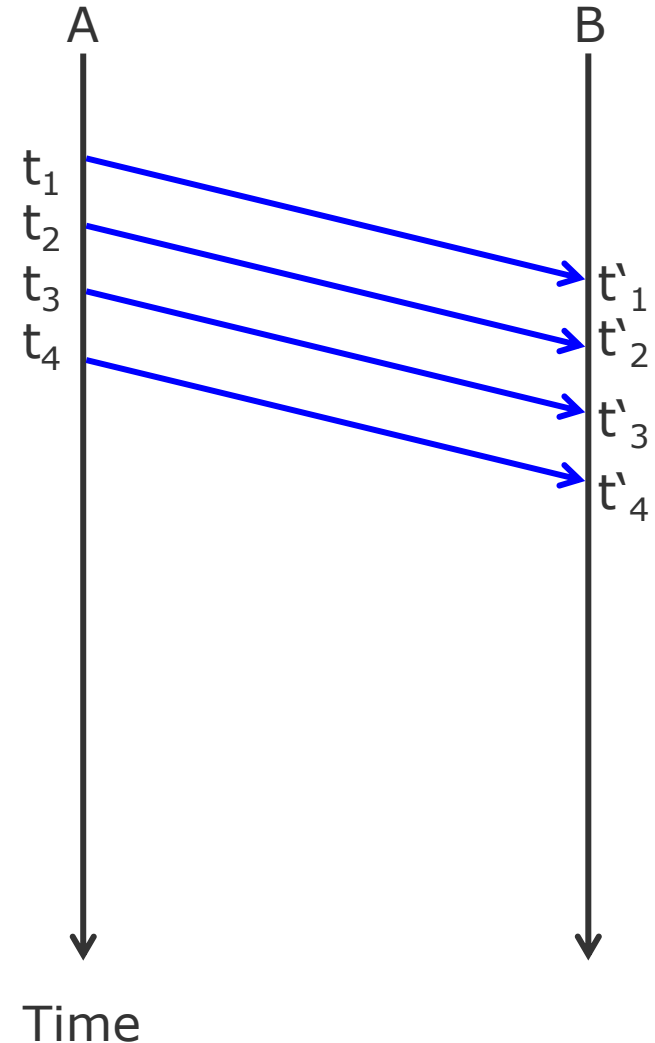

Quality: Technical Performance

- Throughput
 - Measured in bits per second [bps]

$$T = \frac{\sum data_i}{\Delta t}$$

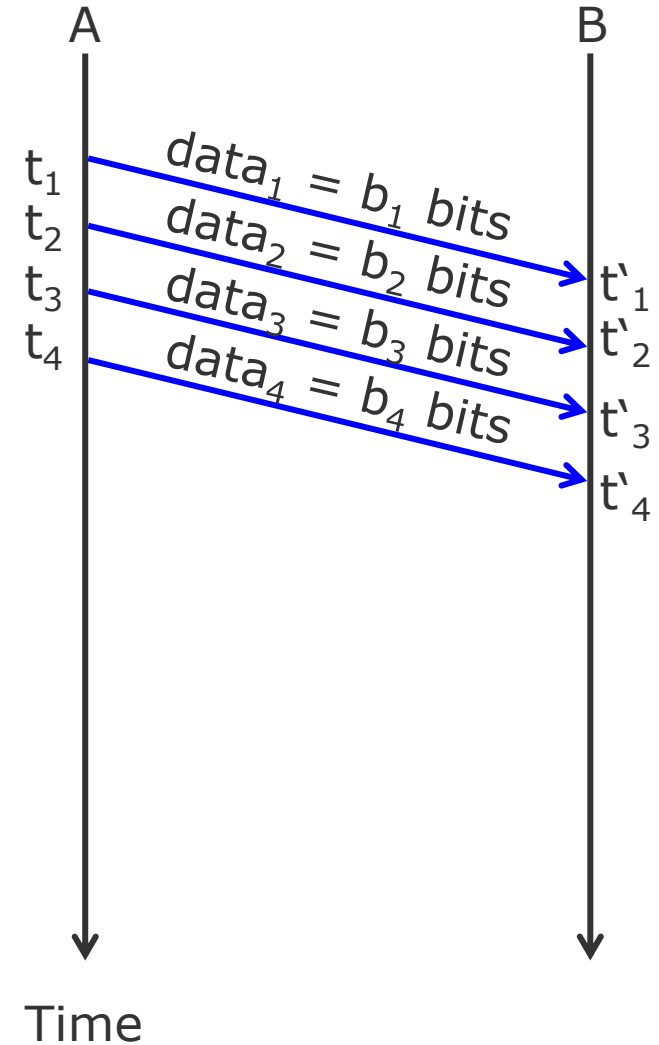

Quality: Technical Performance

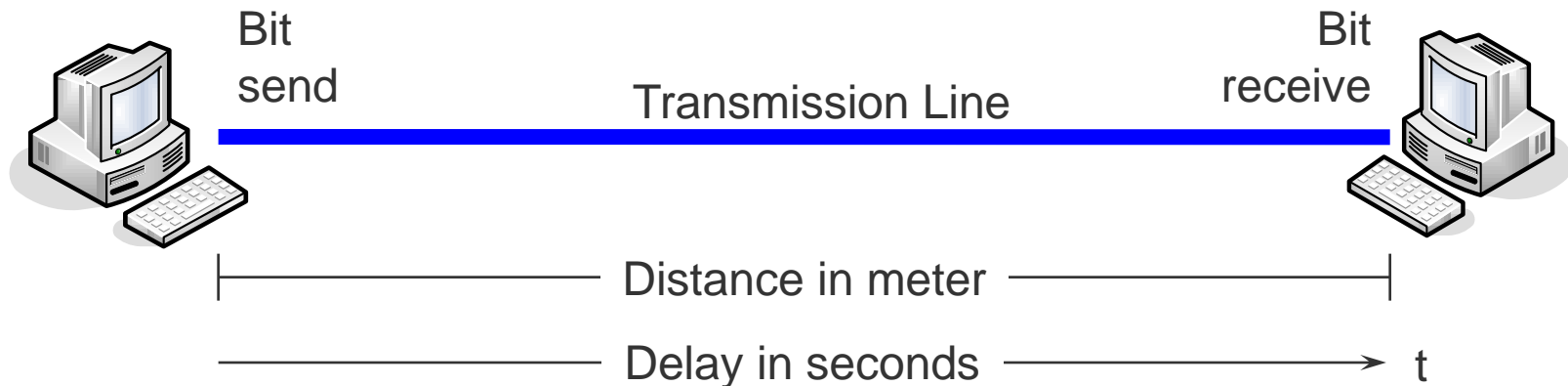

Attention:

Delay-Bandwidth-Product =
Store capacity of the line

Throughput (“bandwidth”, data rate) =
Number of transmitted bits per second [bps, bit/s]

Example: Store capacity of the transmission line

- DSL connection: 1 Mbps, 200 ms delay: $1 \text{ Mbps} \times 0.2 \text{ s} = 200 \text{ kbit}$
- Ethernet 100 Mbps: 100 Mbps, 100 ms: $100 \text{ Mbps} \times 0.1 \text{ s} = 10 \text{ Mbit}$

Quality: Security and Protection

- Safety measures
 - Encryption (cryptographic codes)
 - Trustworthy systems (Authentication, Authorization)

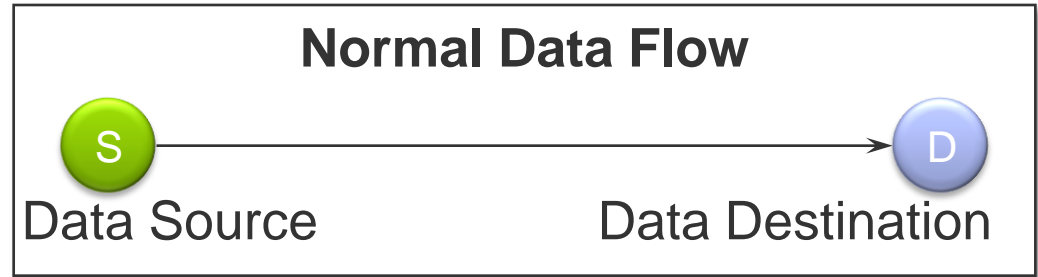

Passive:

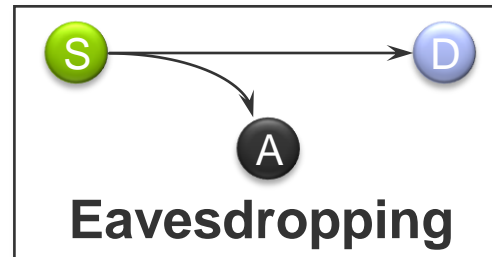

Active:

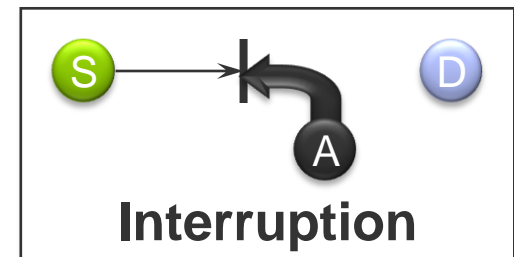
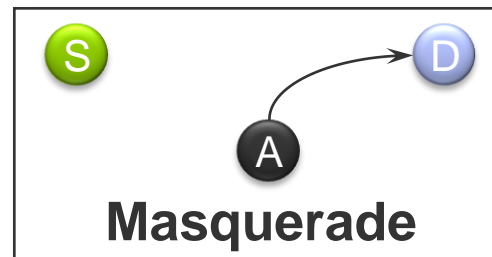
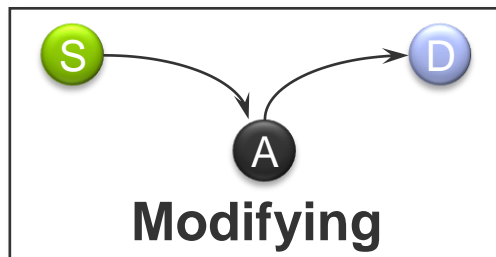

Delivery Principles

- The delivery principle describes how sent data is received by the receiver
 - In sequence, i.e., same order as the data was sent by the sender (FIFO)
 - FIFO + prioritized
 - Random

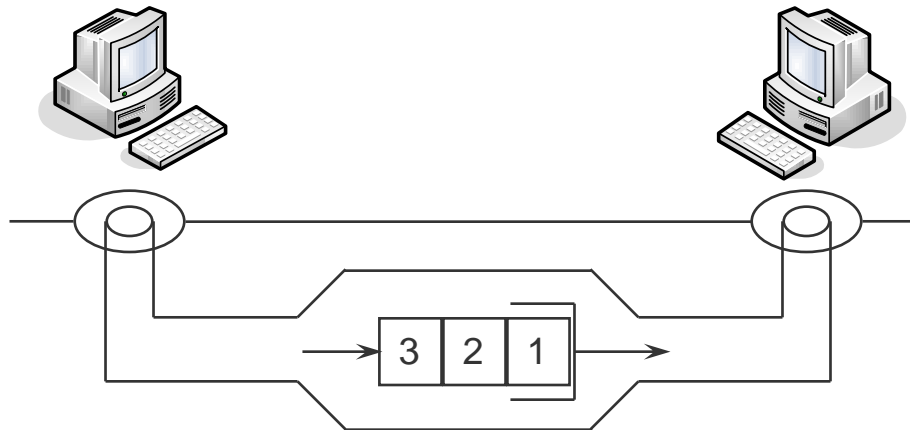

The Client/Server Principle

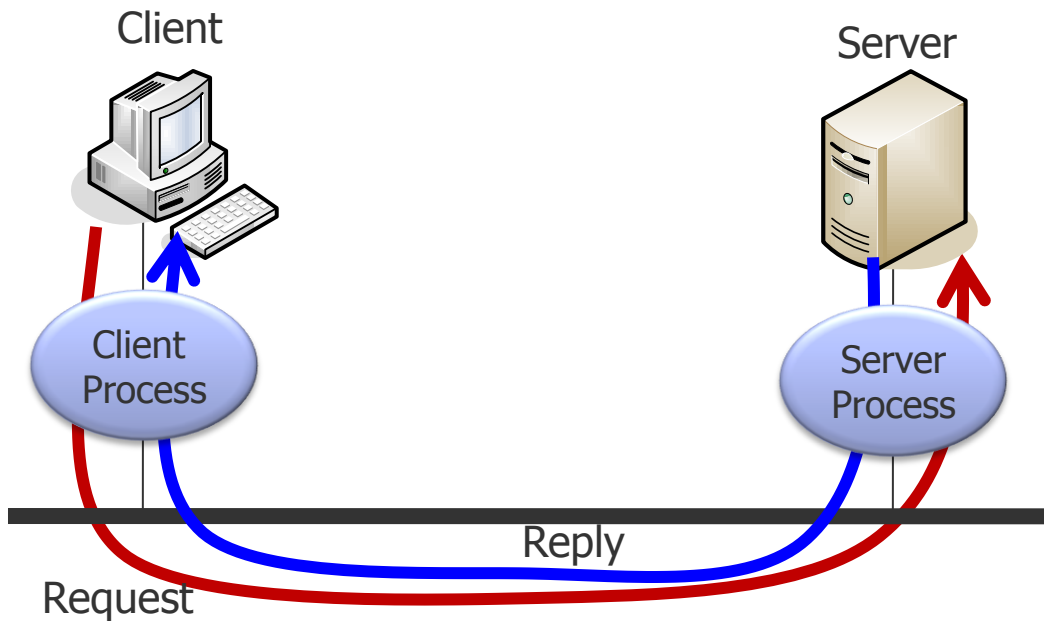

Advantages of the Client/Server principle

- Cost reduction
- Better usage of resources
- Modular extensions
- Reliability by redundancy

The Client/Server Principle

● Server

- Program (process) which offers a service over a network.
Servers receive requests and return a result to the inquiring party. The services offered include simple operations (e.g. name server) or a complex set of operations (e.g. web server).

● Client

- Program (process) which uses a service offered by a server.

Examples for Client/Server Systems

Client	Server
Web Browser	Web Server
E-Mail Program	Domain Name System (DNS)
FTP Client	FTP Server

Peer-to-Peer Principle

- The P2P Principle
 - Equal partners, no fixed client and server roles
 - Connections between any pair of computers
 - Establishment of a network of connections
 - Example: File Sharing, e.g., Napster, Gnutella

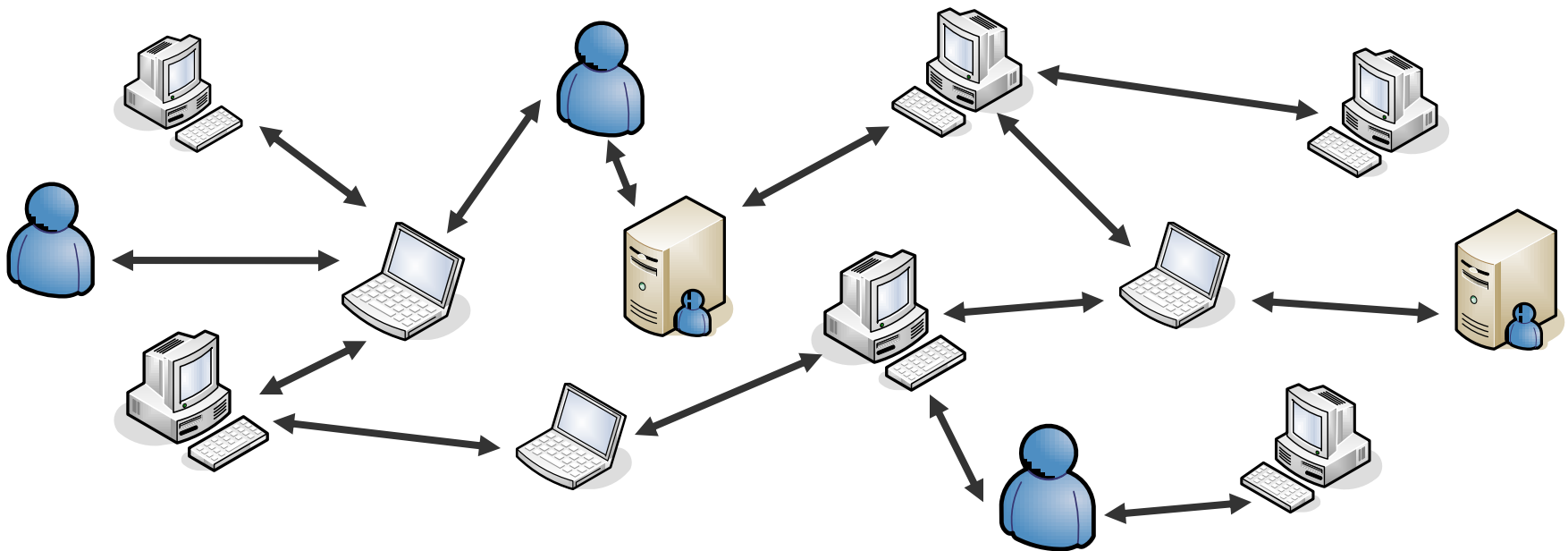



Non-technical Aspects of Networking

Non-technical Aspects of Networking

Computer Networks

- Communication networks enable a fast and cheap exchange/distribution of information. There is however a large number of social, ethical, cultural, juridical ... side effects.

Side effects ...

- Eventually dubious or forbidden contents
- Responsibility
- Juridical aspects (legislation)
- Potential censorship?
- Control over the productivity of employees, of the whereabouts of people
- Annoyance through anonymous or unwanted messages (SPAM)
- ...

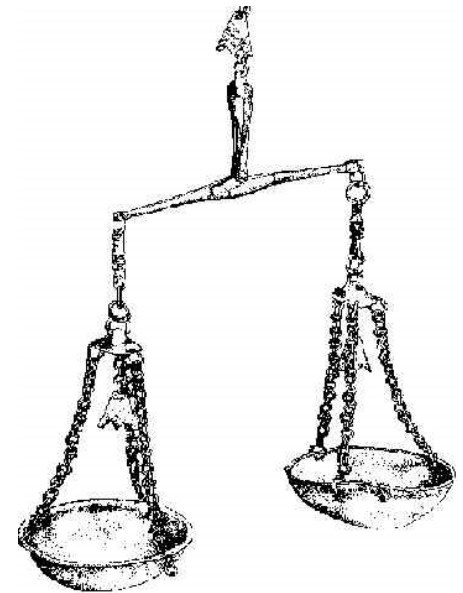



Communication Protocols

What is a Protocol?

- Human protocols:
 - “What’s the time?”
 - “I have a question”
 - Introductions
- In General
 - ... specific messages sent
 - ... specific actions taken when messages received or other events happen
- Network protocols:
 - Machines rather than humans
 - All communication activities in the Internet is governed by protocols
- In General
 - Protocols define format, order of messages sent and received among network entities, and actions taken on message transmission and receipt



What is a Protocol?

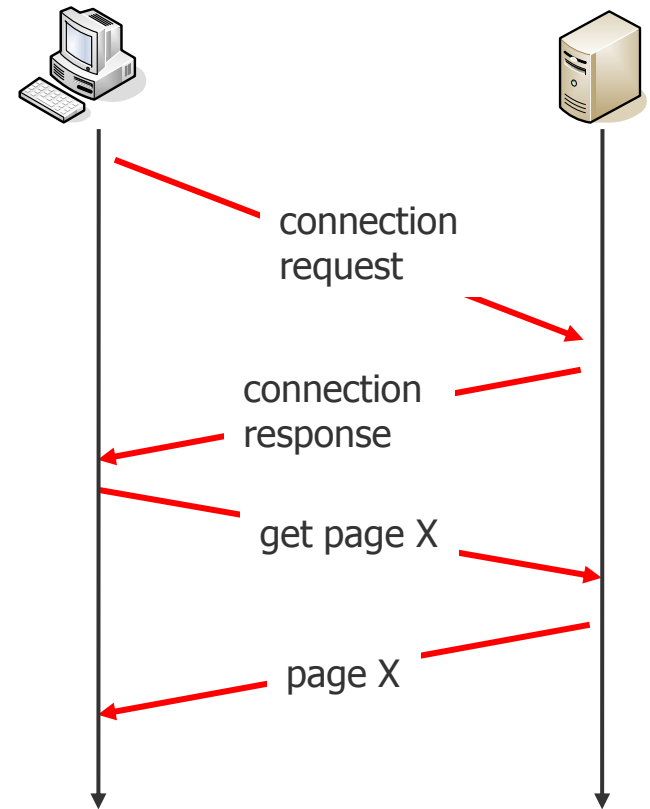
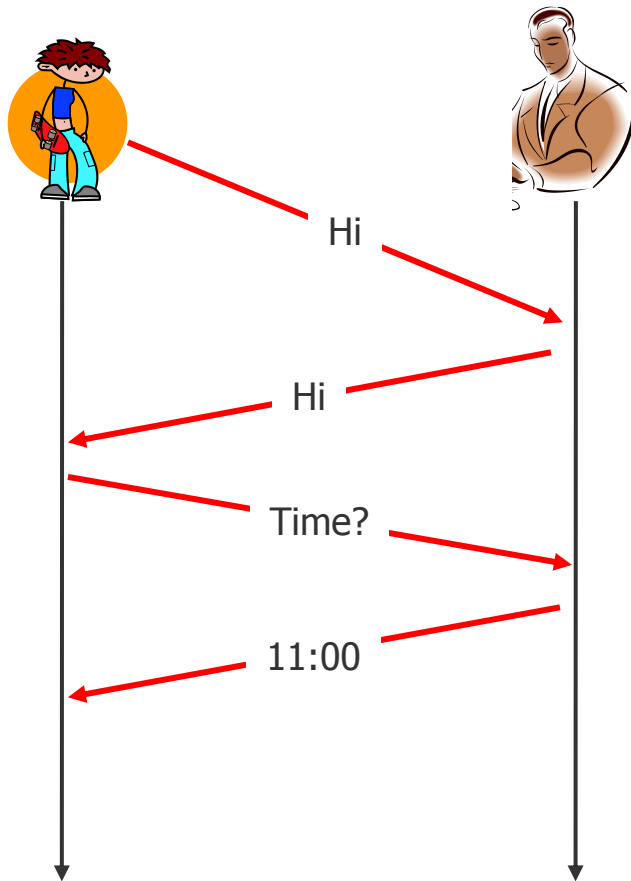

Why Protocols?

To enable understanding in communication, all communication partners have to speak the same “language”.

- Data formats and their semantics
- Control over media access
- Priorities
- Handling of transmission errors
- Sequence control
- Flow control mechanisms
- Segmentation and composition of long messages
- Multiplexing
- Routing

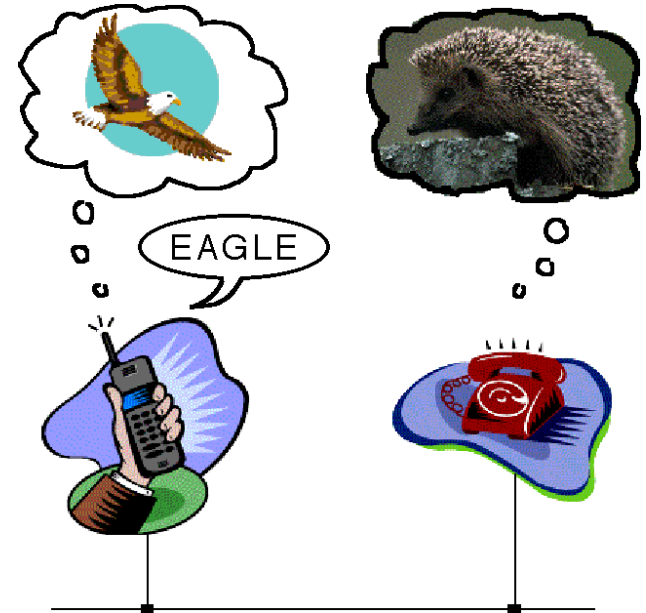

Protocol

A protocol is defined as the set of agreements between (application) processes with the purpose of a communication.

Implementation of Protocols

Solution 1

- Write one large “Communication Program” which fulfills all requirements needed to establish a communication process.
- Advantage: efficient data exchange for a given application.
- Disadvantage: No flexibility! Adoptions require large efforts.

Solution 2

- Write a set of small programs specialized to special tasks of the communication process. For each application, the needed programs can be combined.
- Advantage: Very flexible, since single components can be exchanged.
- Disadvantage: Fixed structures of program interworking; adds more complexity and overhead.

Accepted today: Solution 2

- The implementation takes place in **layer models**.



Example: Exchange of Ideas between Philosophers

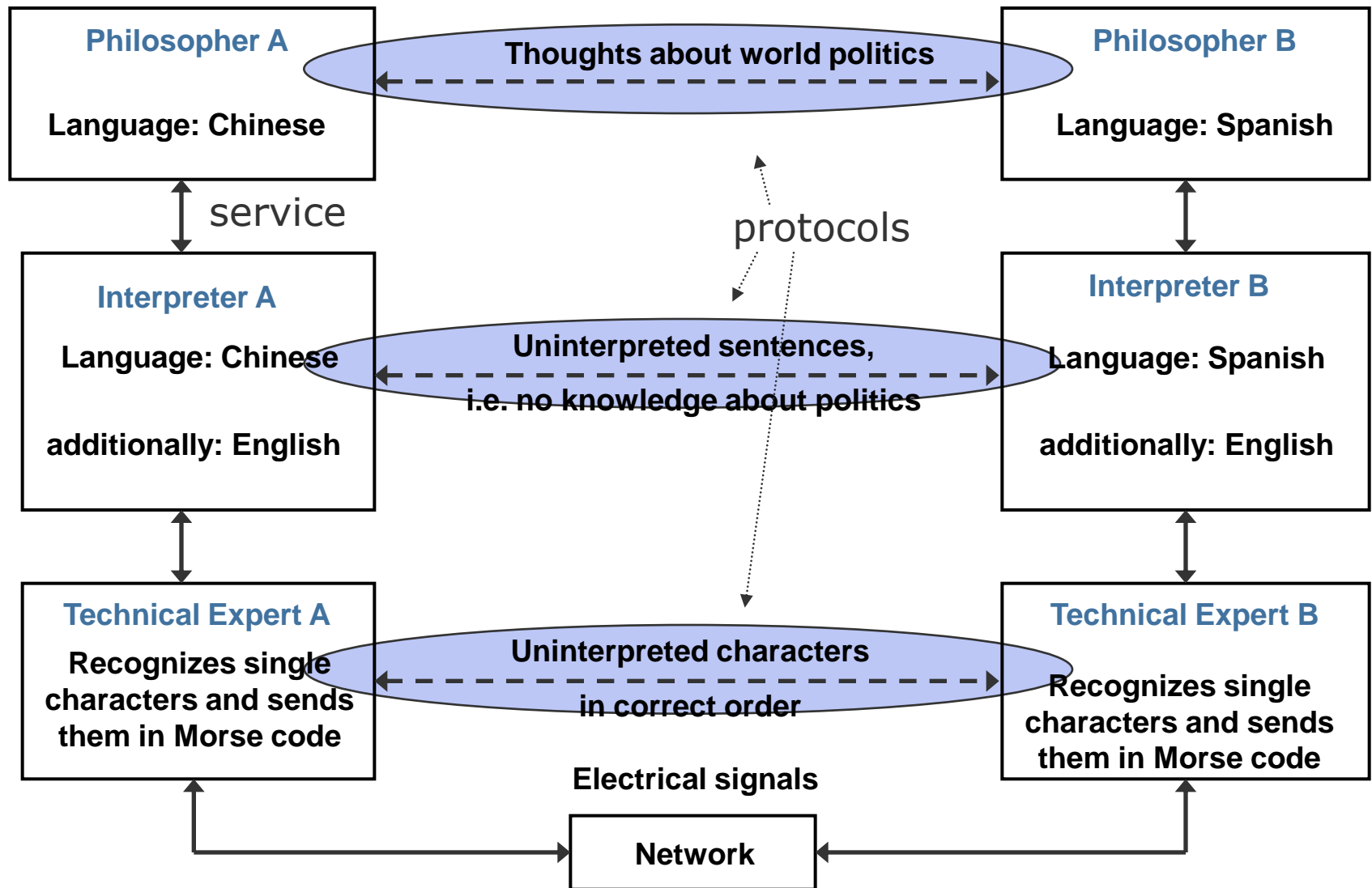



Services and Protocols

- Peer of a Layer
 - use one service (except the bottom)
 - offer a service (except the top)
 - do not need to know other than the next lower one
 - talk according to the rules
 - Telephone: dial/ring/busy
 - With humans often context sensitive

- Communications architectures are based on
 - Service = Communication Service
 - Rules = Communication Protocol

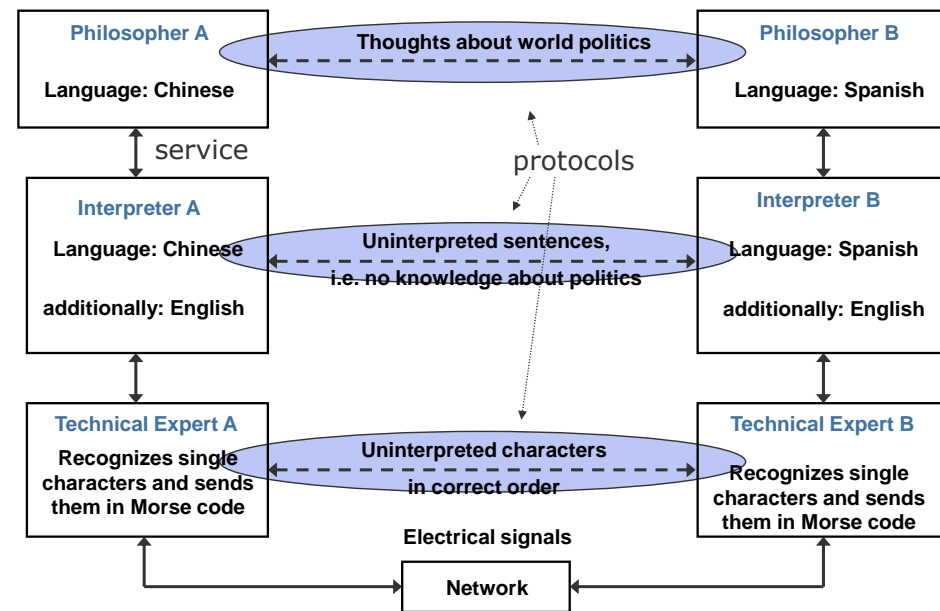



Services and Protocols: Example Telephone System

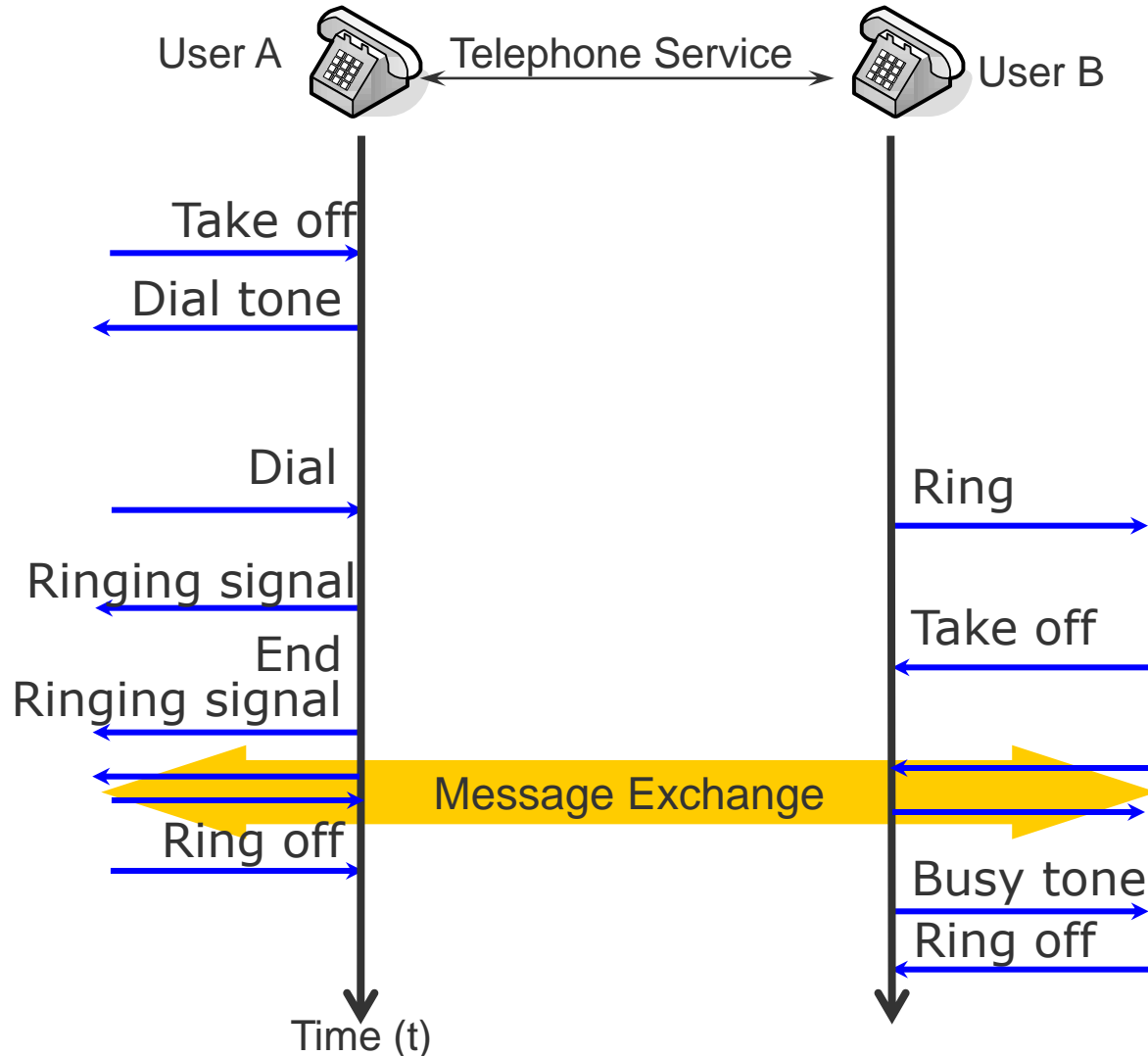



Services and Protocols: Example Telephone System

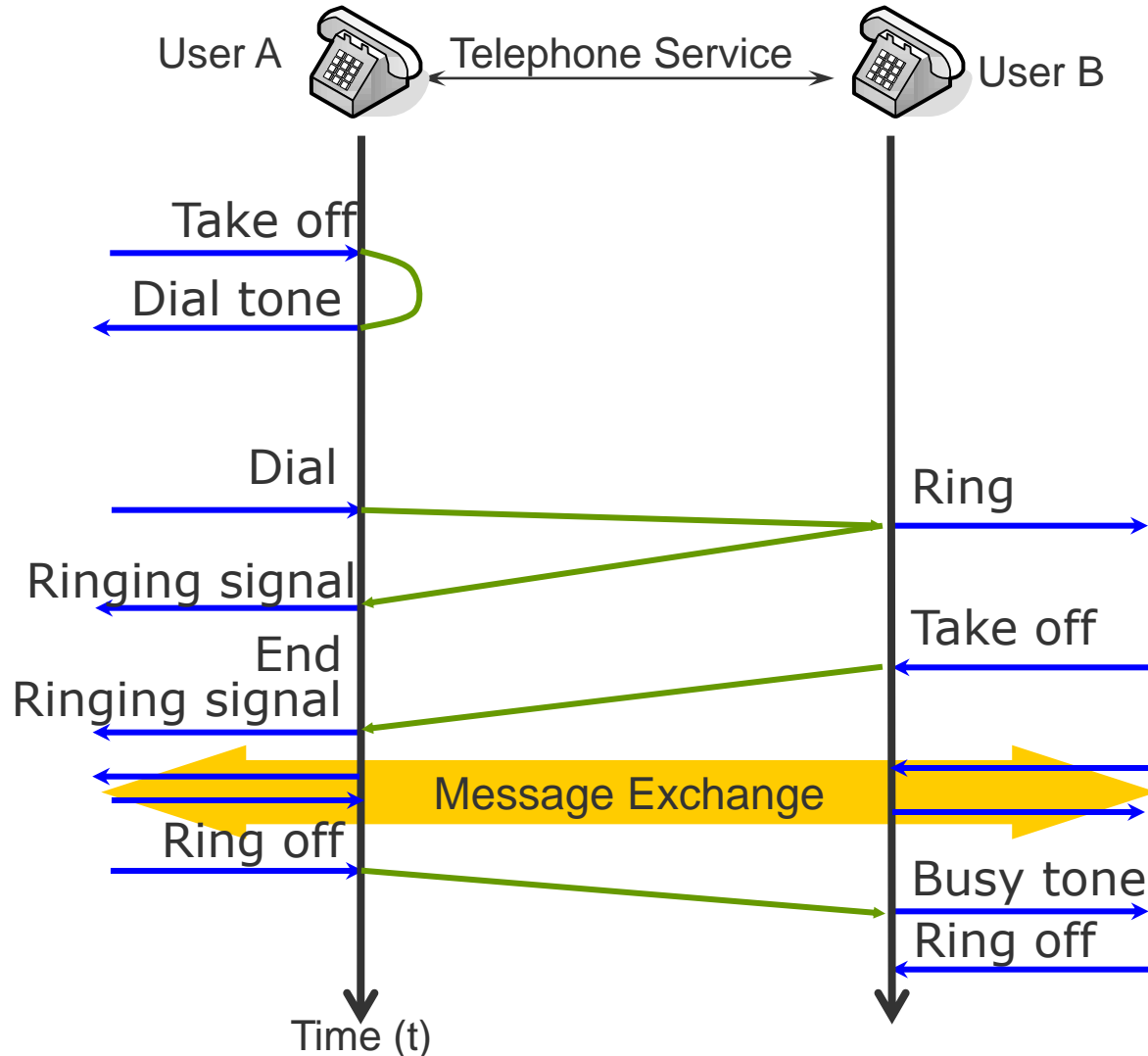



Services and Protocols: Example Telephone System

- Signaling protocol in the plain old telephone service (POTS)

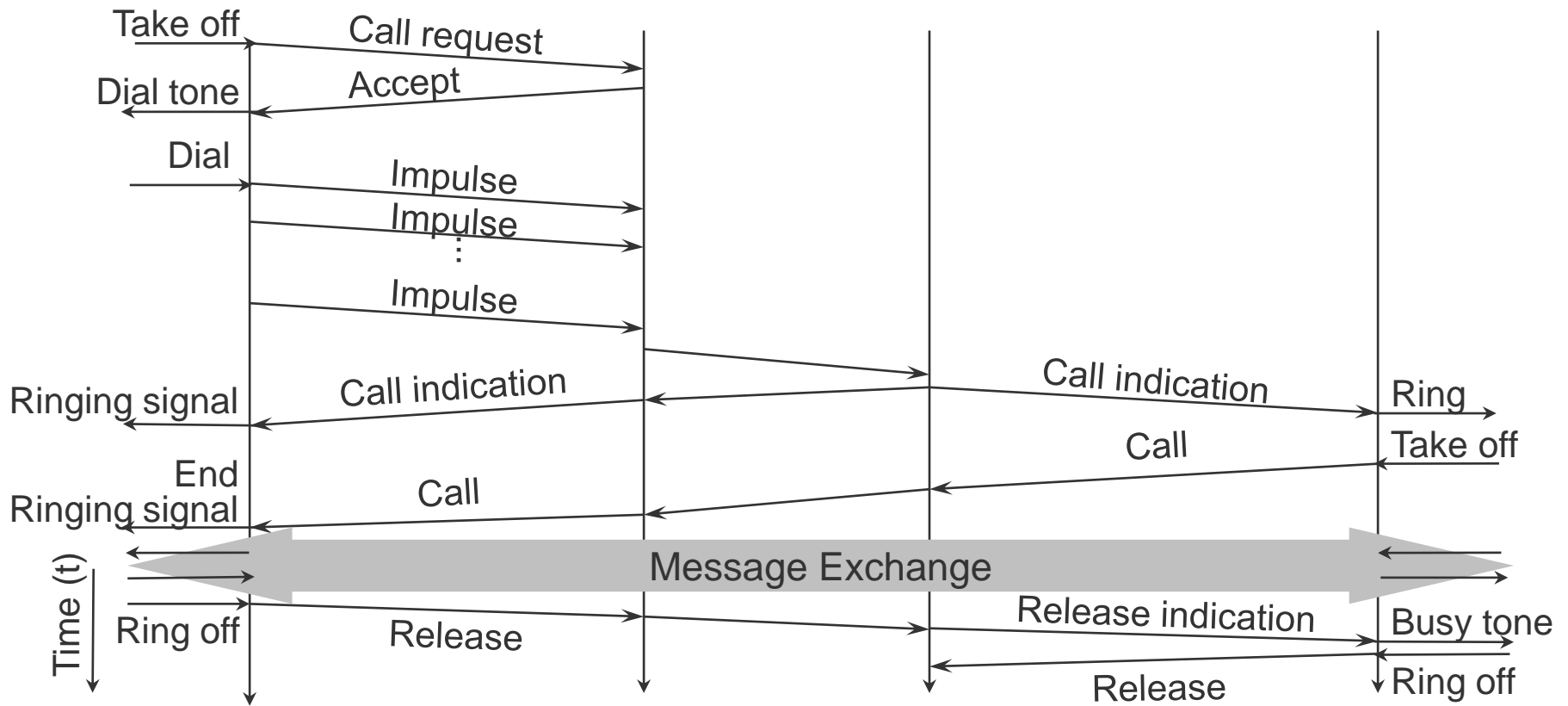
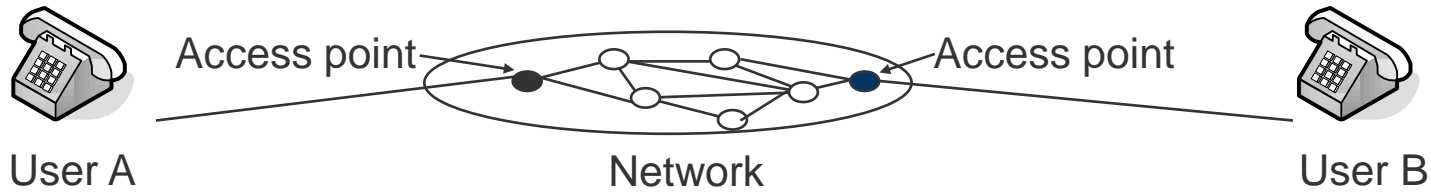

The Notion of Service

- Functionality of a layer is offered as a **set of services**
- The service in a layer is realized by data exchange between peers. The exchange of these data is according to **rules and formats**, which is denoted as **protocol**.
- A service is offered from a **service provider** at a **service interface** to **service users**
- The **service definition** specifies the available services and rules for its usage
- Types of services are:
 - Request
 - Indication
 - Response
 - Confirmation

The Notion of Service

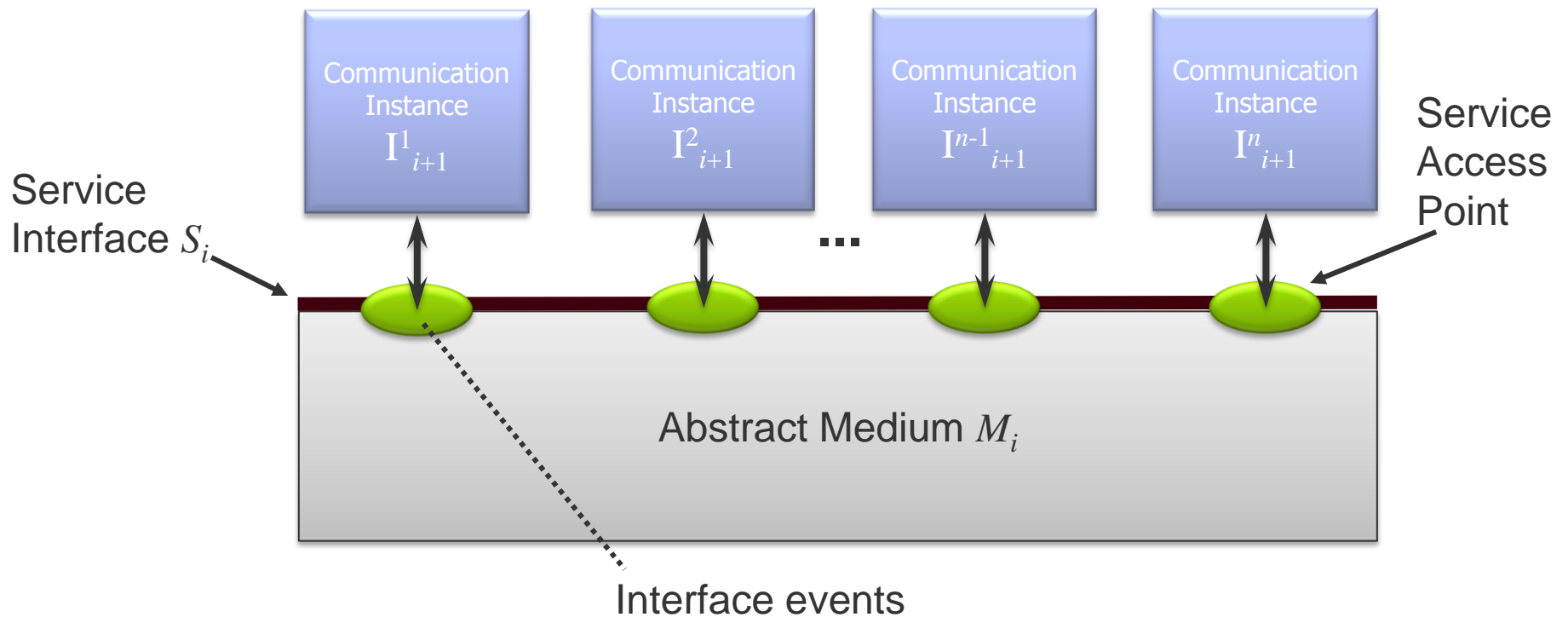

Service of Layer N

- Layer-(N) Service
 - Set of functions, which Layer-(N) provides to the (N+1)-Instances at the interface between Layer-(N) and Layer-(N+1)
 - Vertical communication
 - The (N)-Instances provide the functions of Layer-(N) by exchanging of particular data
 - Horizontal communication
 - For this, they use the services of Layer-(N-1)
 - The implementation of the service on Layer-(N) is hidden from Layer-(N+1)

Relationship of Services to Protocols

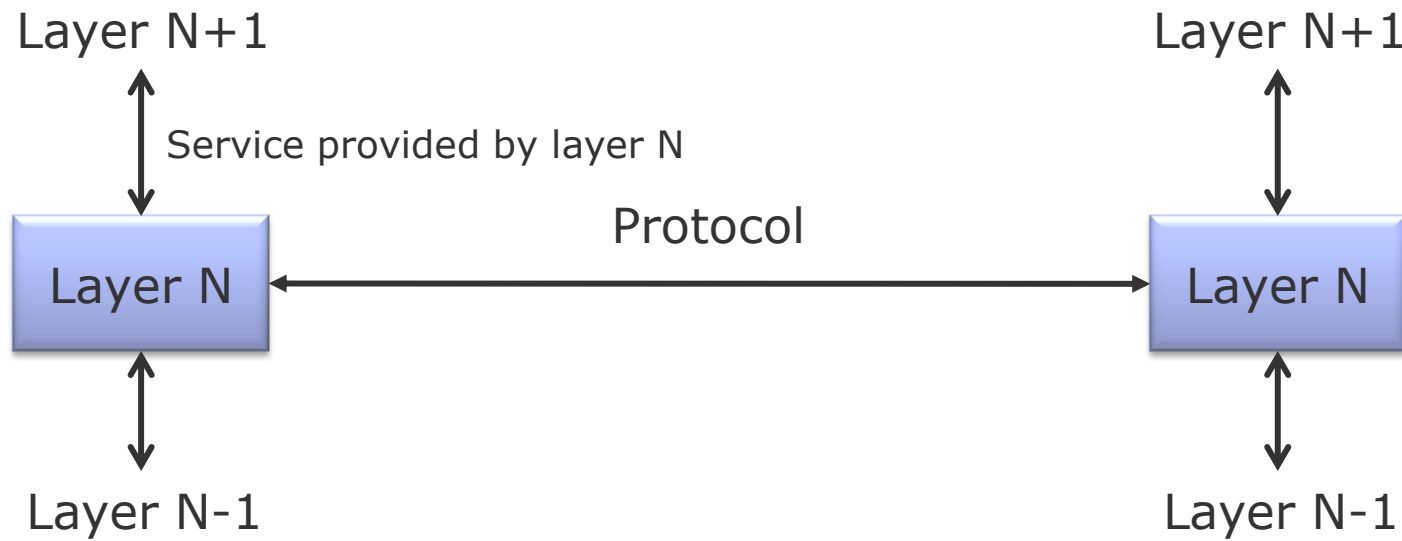



Horizontal vs. Vertical Communication

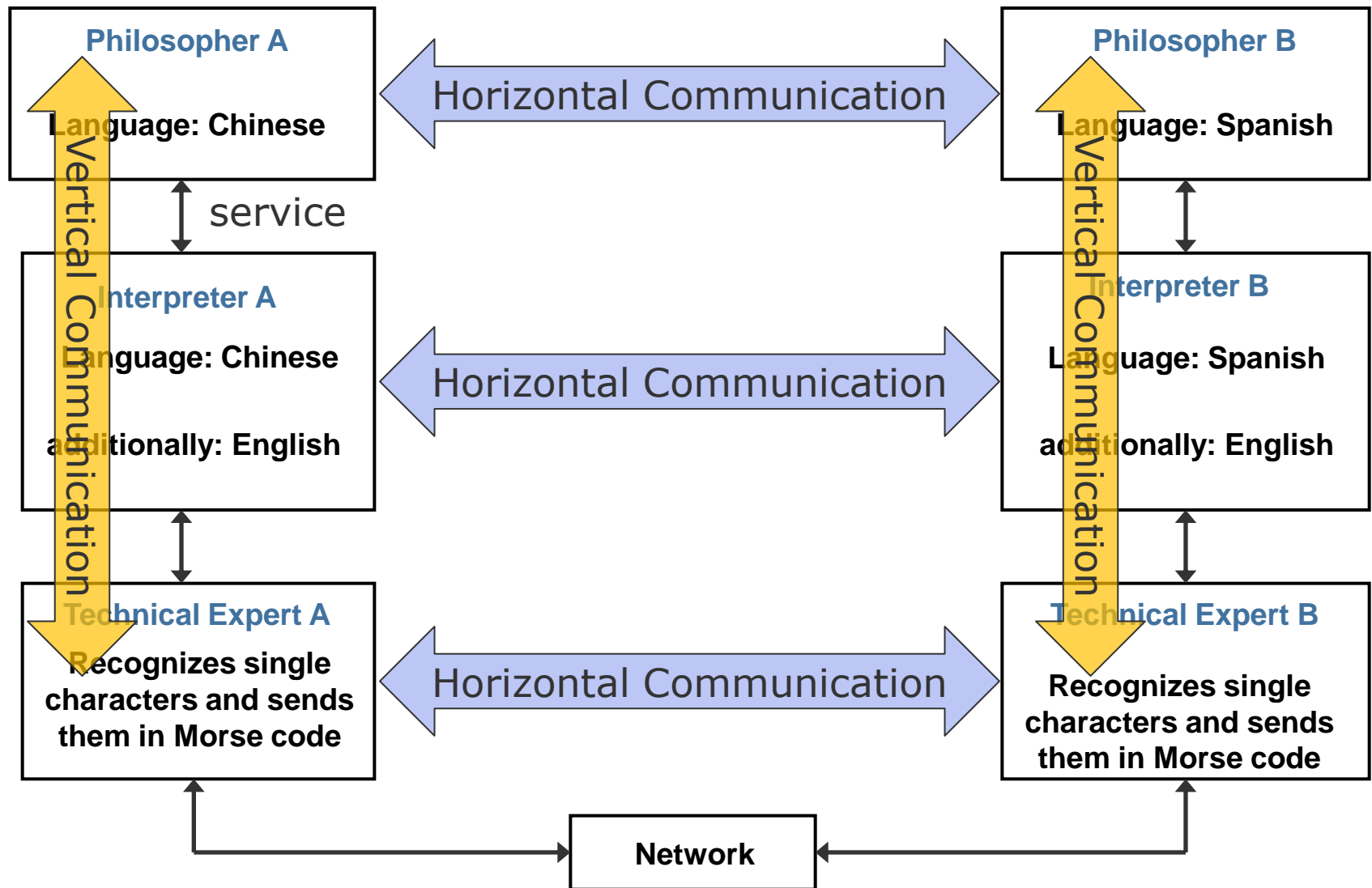

Types of Services

- Unacknowledged Service

- Modeled after the postal service
- Initiated by the service user

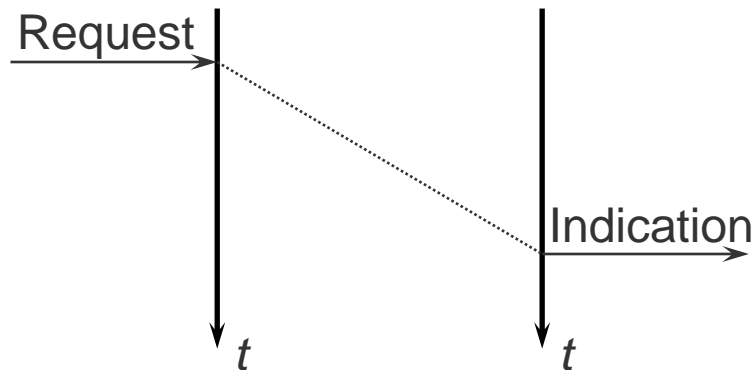

- Initiated by the service provider

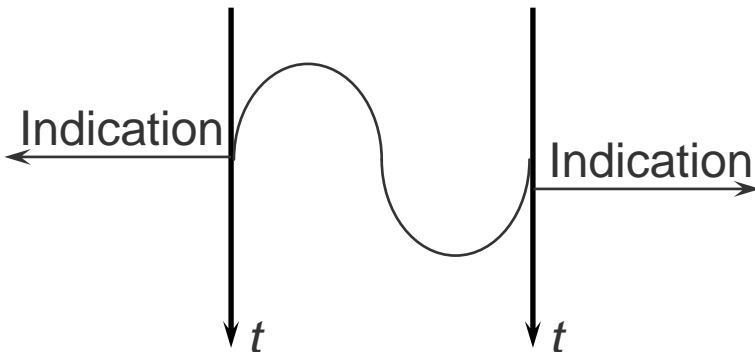

- Acknowledged Service

- Transaction
- Initiated by the service user

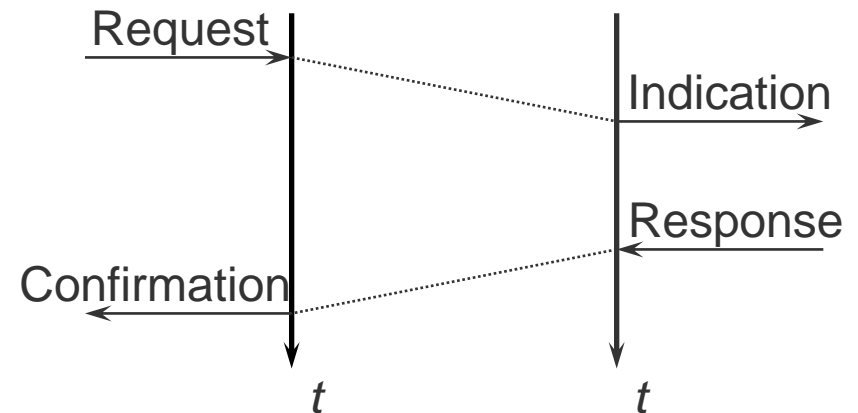

Types of Services

● Connection-oriented Service

- Modeled after the telephone system
- Before the instances on Layer-(N) can exchange data, a connection on Layer-(N-1) has to be established
 - Request of such a connection is done by the services provided by Layer-(N-1)
- Negotiation of protocol parameters
 - Buffer size
 - Quality of Service (QoS)
 - Routes, etc.
- Exchange of data happens in respect to these parameters
 - Communication context

● Connectionless Service

- Modeled after the postal service
- No establishment of connection on a lower layer required
- Each data exchange is independent from others
 - No communication context



Connection-oriented Service

3 Phase Principle

1. Connection establishment

- Context creation
 - End systems
 - Network

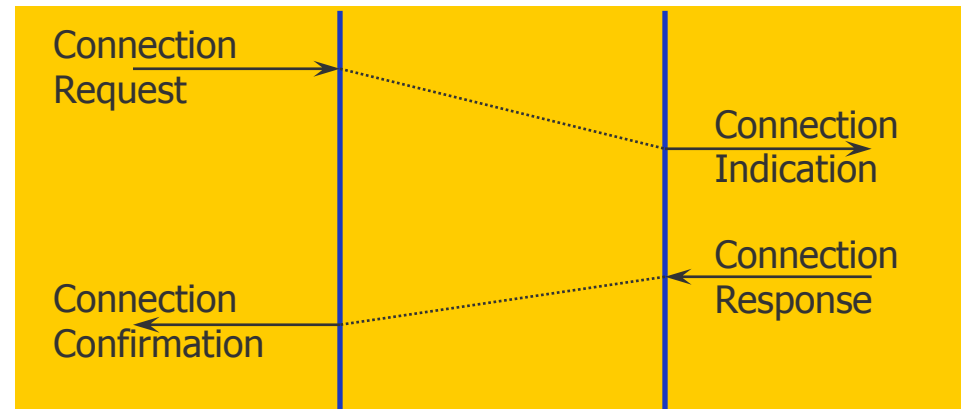

2. Data exchange (simplex)

- Data transmission is done within the context

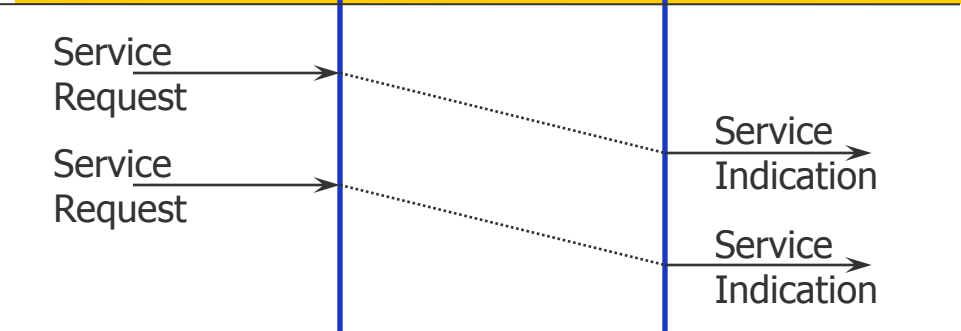

3. Connection termination

- Context release
- Resource release

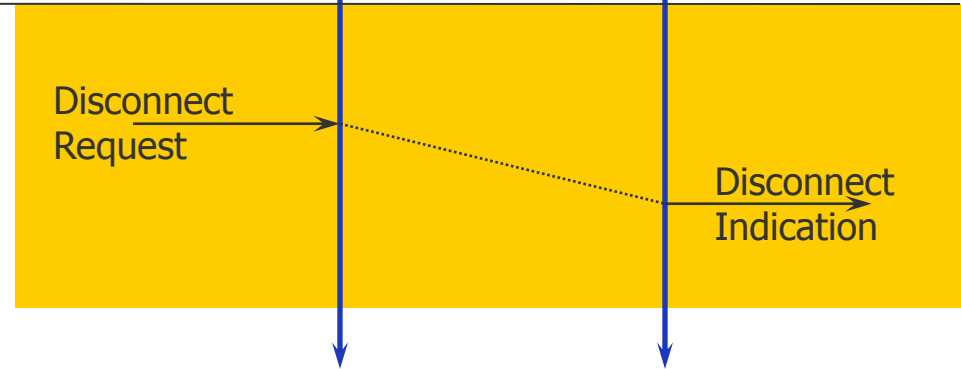

Connectionless Service

- Connectionless Service is also called **Datagram Service**
 - Does not provide relationship between transmissions
 - Does not guarantee the sequence of send data
 - Does not provide reliability
 - No acks!

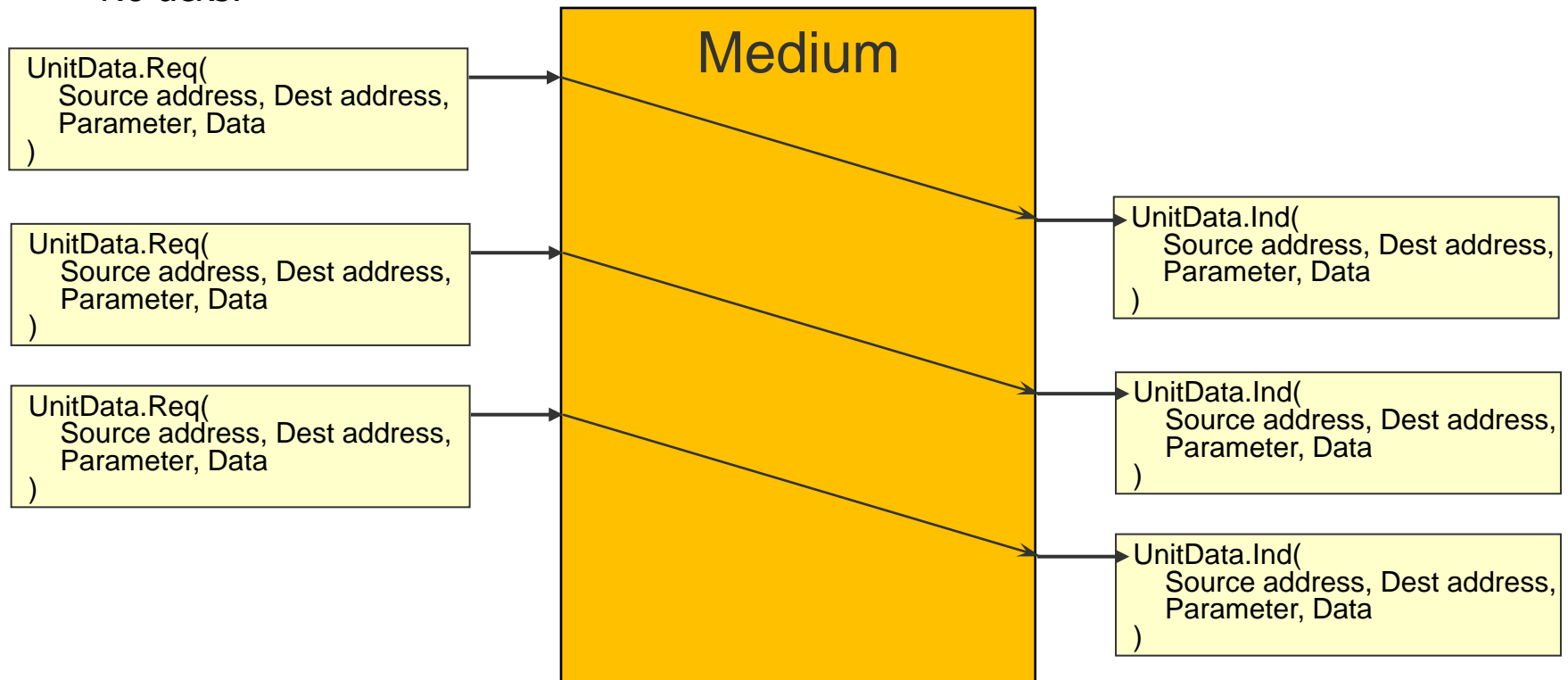

Addressing of the Service User

- Datagram Service

- Request: Address of the destination
- Indication: Address of the source

- Connection-oriented Service

- The context of the connection contains also address information

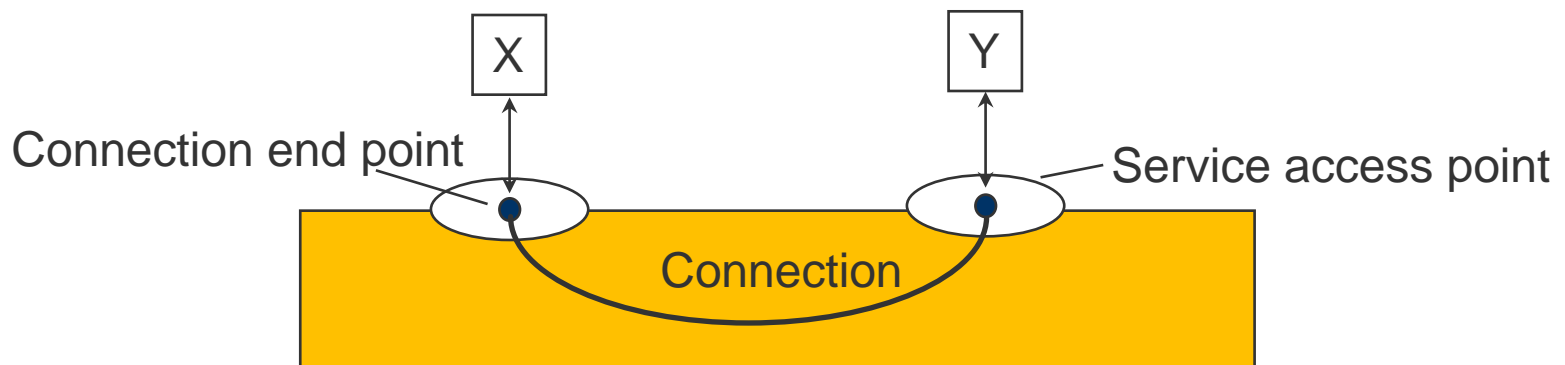

Types of Services: Example Services

	Service	Example
Connection-oriented	Reliable message stream	Sequence of pages
	Reliable byte stream	Remote login
	Unreliable connection	Digitized voice
Connection-less	Unreliable datagram	Electronic junk mail
	Acknowledged datagram	Registered mail
	Request-reply	Database query

Service Primitives

- Five service primitives for implementing a simple connection-oriented service.

Primitive	Meaning
LISTEN	Block waiting for an incoming connection
CONNECT	Establish a connection with a waiting peer
RECEIVE	Block waiting for an incoming message
SEND	Send a message to the peer
DISCONNECT	Terminate a connection



Service Primitives

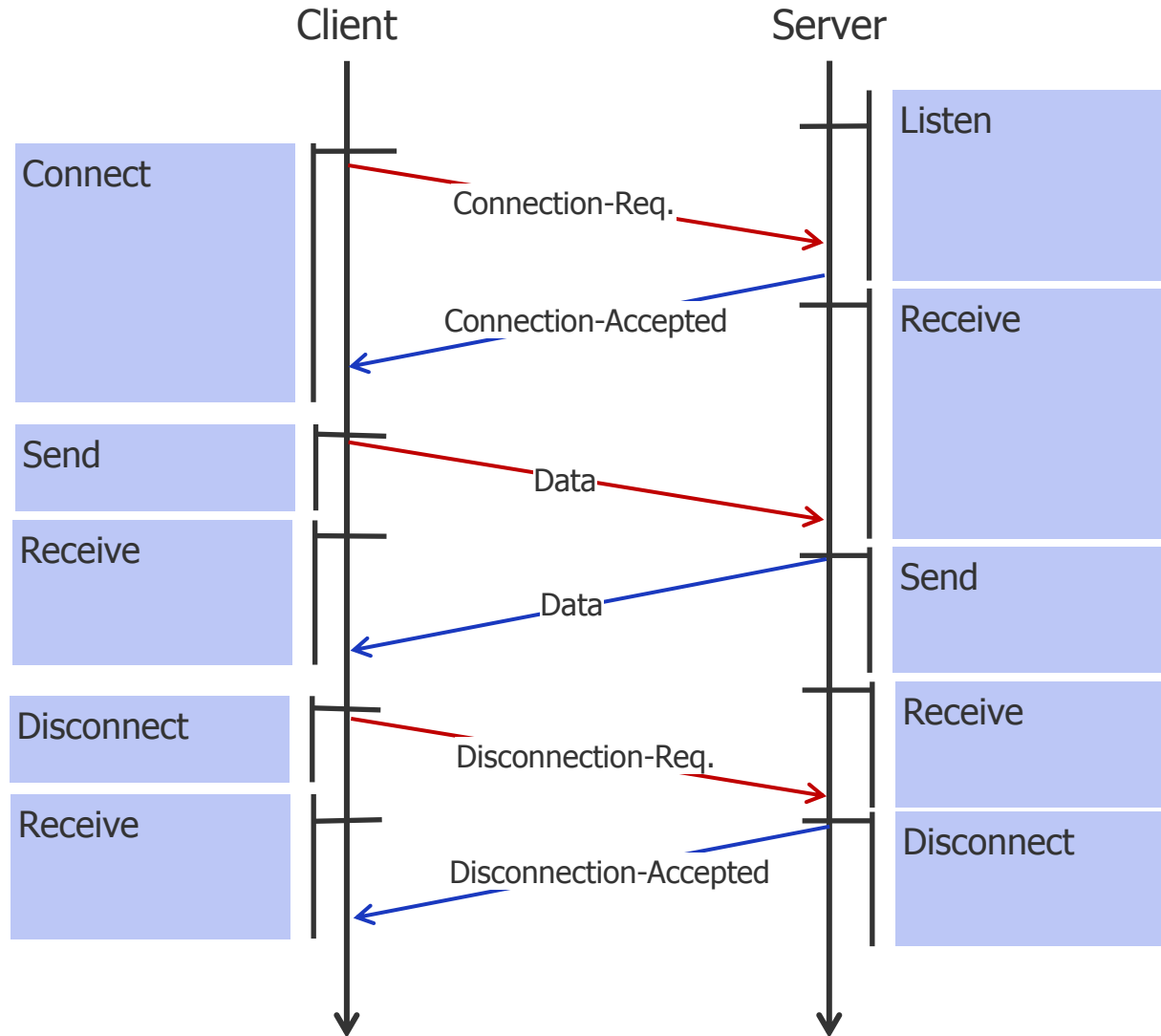

Service Primitives

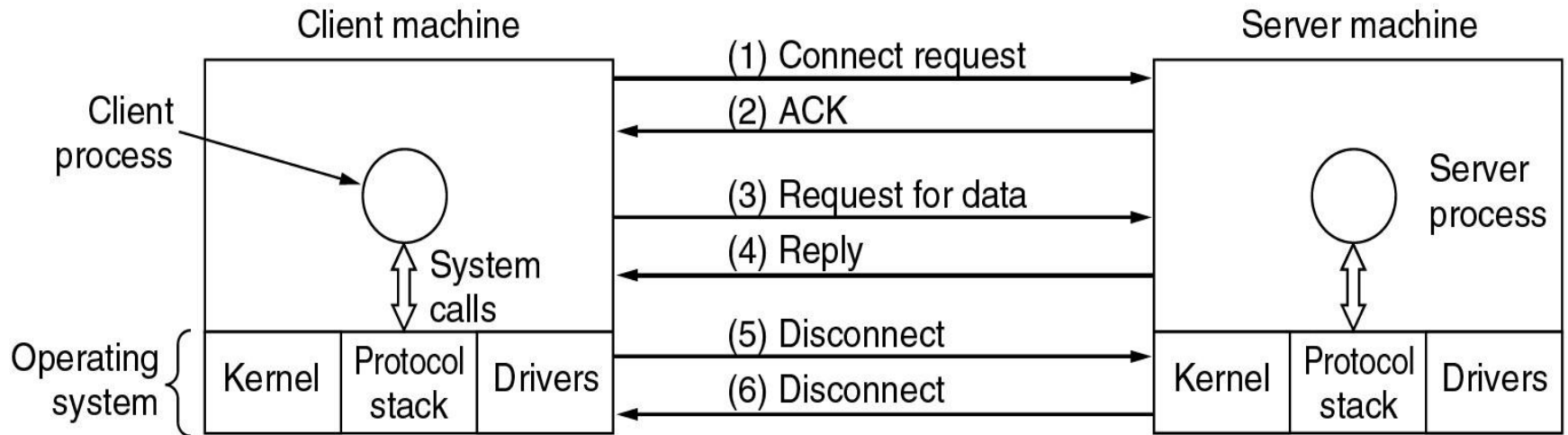



The ISO/OSI Reference Model

The ISO/OSI Reference Model

Reduce the complexity of a communication process through layers.

The 7 ISO/OSI layers:

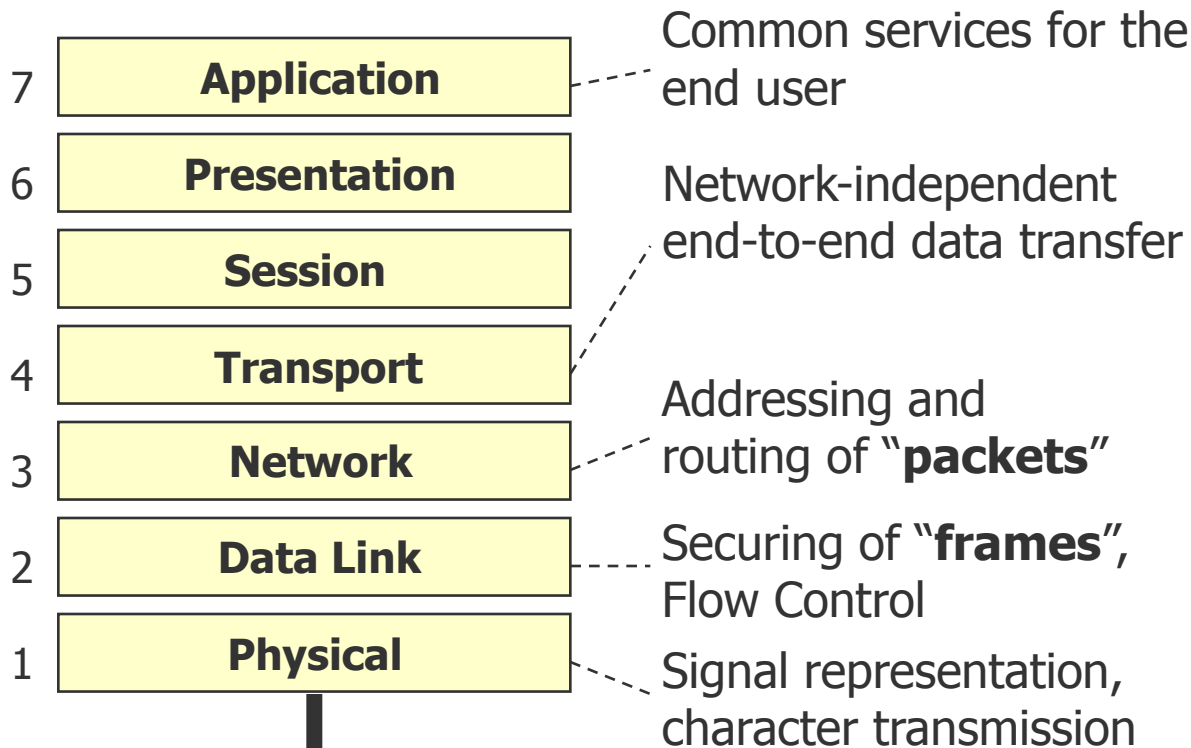

Criticism of the model

Layer 5 and 6 are rarely implemented

Generally too much overhead – some details are unnecessary, some layers are overloaded

Transmission medium ("Layer 0")

Layer Tasks

1. Physical layer

- This layer is responsible for transmitting **single bits** over the medium.
- **Signal representation** is defined to ensure that a sent "1" is understood by the receiver as "1". For example it defines which voltage represents a "1" resp. a "0" and how long the voltage has to be for one bit.
- Moreover, definition of details like the **type of cables, meaning of pins** of network connectors, **transmission direction** (uni-/bidirectional), ...

2. Data Link Layer

- Ensures an **error-free** data transmission between two connected hosts.
- Incoming data are segmented into **frames** which are transmitted separately. The receiver checks if the transmission has been **correct** (use of a checksum).
- Additionally, **flow control** is used to control the re-transmission of corrupt frames and protect the receiver from overload.
- In broadcast networks the control of the **medium access** is defined.

Layer Tasks

3. Network Layer

- This layer is responsible for the data transmission over large distances and between heterogeneous networks.
- One main task is (worldwide) uniform **addressing** of hosts.
 - A necessary pre-requisite is a common address range
- Other main task is **routing**, i.e., choosing a path through the network.
 - Intermediate stations (**routers**) manage routing information and use the uniform addresses to decide about the best path to the receiver.
- **Quality of Service (QoS)** issues, i.e., if too many packets are present at the same time in the network, they may form bottlenecks.
 - Forming of **congestion**.
 - An agreement about a **maximum** size of the **transmission** data **unit** (MTU).
 - Control of delay, jitter, transit time, etc.

Layer Tasks

4. Transport Layer (ISO/OSI)

- Layer 4 manages **end-to-end communication** between two **processes**.
- Ensures that the data are transmitted **complete** and in **correct order**.
 - For this, again **flow control** is used (sequence numbers, acknowledgements) to detect missing or wrong ordered data units.
- Beneath this, the current network state is considered to adapt to the receiver and to the network capacity.
- **Addressing** is a topic here as well. On the transport layer, a single **communication process** on the receiver side is addressed.

5. Session Layer

- This layer (like the transport layer) manages reliable data transport between two hosts (End-2-End). However, additional services are being offered, like
 - Dialogue control
 - Token Management
 - Synchronization points

Layer Tasks

6. Presentation Layer

- Represent the data in an platform independent format
 - Some computers code a string with ASCII others use Unicode, some use for integers the 1-complement others the 2-complement.
 - Instead of defining a new transmission syntax and –semantics for every application, the goal is to provide a universally valid solution.
- Data are **encoded** in an **abstract** (and commonly recognized) **data format** before the transmission and are coded back by the receiver into its own data format.

7. Application Layer (ISO/OSI)

- In this layer (standard-) protocols are provided which can be used from a set of applications and computer systems, e.g., file transfer.
- On the application layer a universally valid protocol including an interface to file transfer is provided. For systems from different manufacturers only the link-up into the local file system has to be realized.

Interplay between the Layers

- Layer (N-1) offers its functionality to the above lying layer N as a communication service.
- Layer N enhances the data to be sent with control information (**Header**) and sends the data together with the header as **Protocol Data Units (PDU)**.
- Two communication partners on layer N exchange PDUs by using the communication service of the lower layer (N-1).
- For layer (N-1), these PDUs are the data to be transmitted.

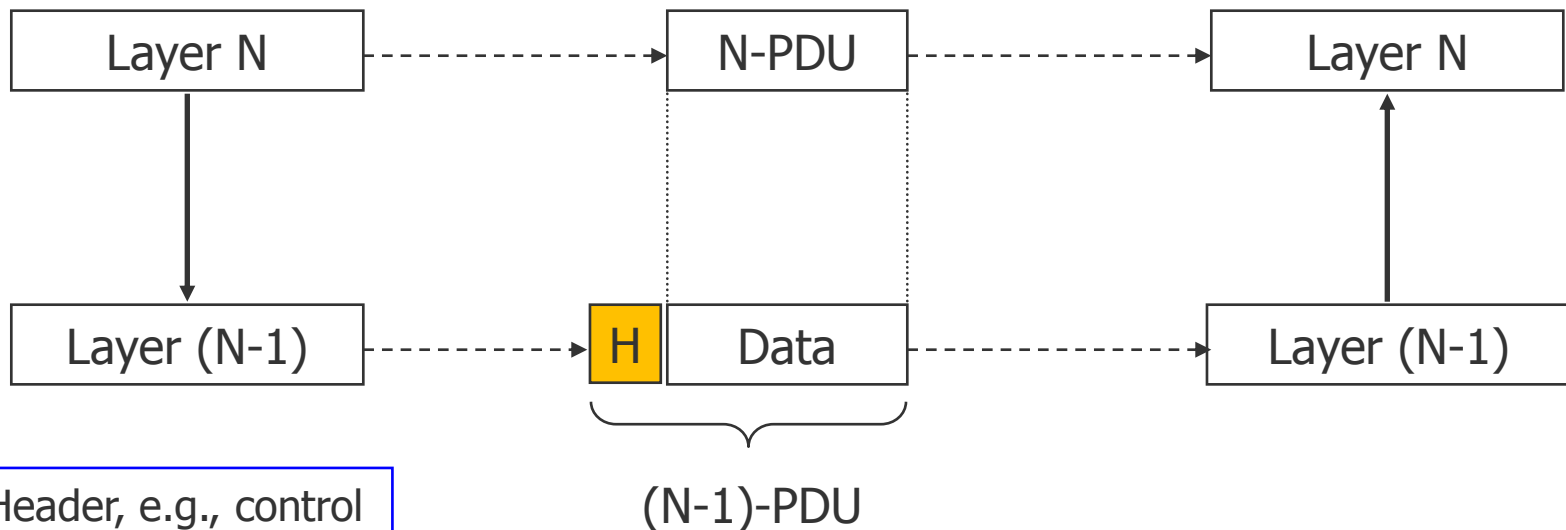

H: Header, e.g., control information of the layer

The whole Communication Process

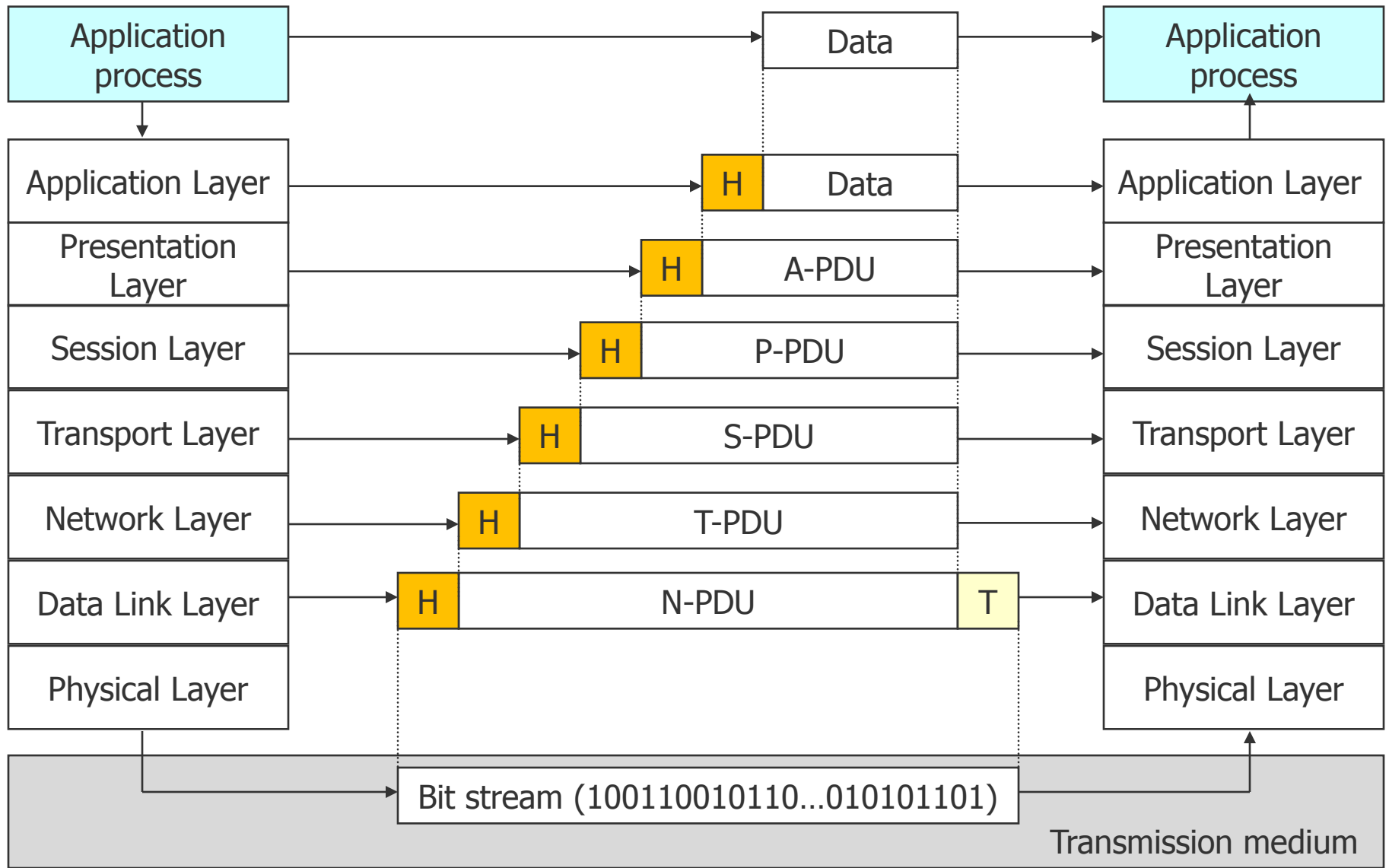

The Communication Process

- Not necessarily a one-to-one mapping between layers
- Depending on the protocol, N-PDUs can be segmented into several (N-1)-PDUs before transmission:

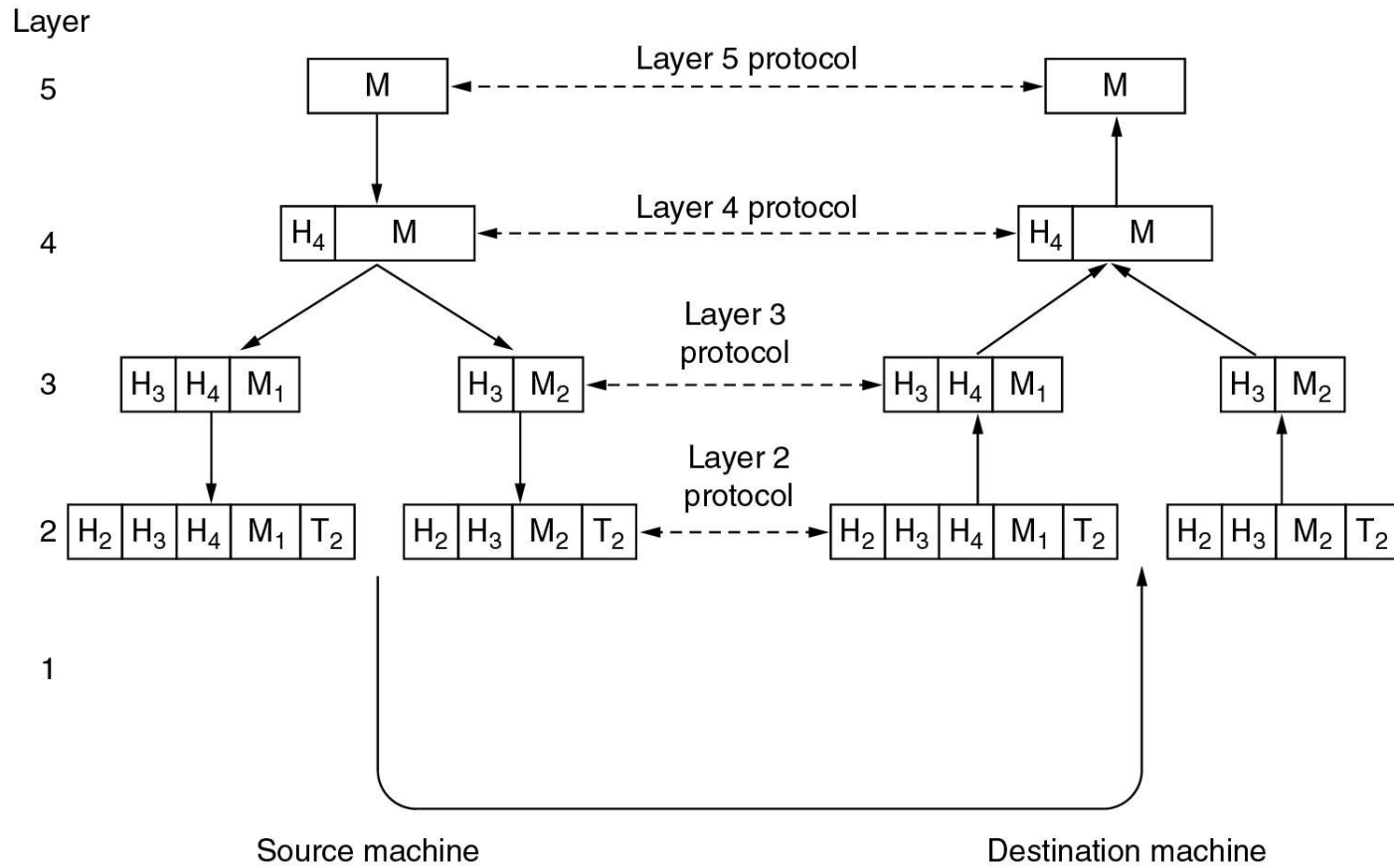

The OSI Reference Model in the Network

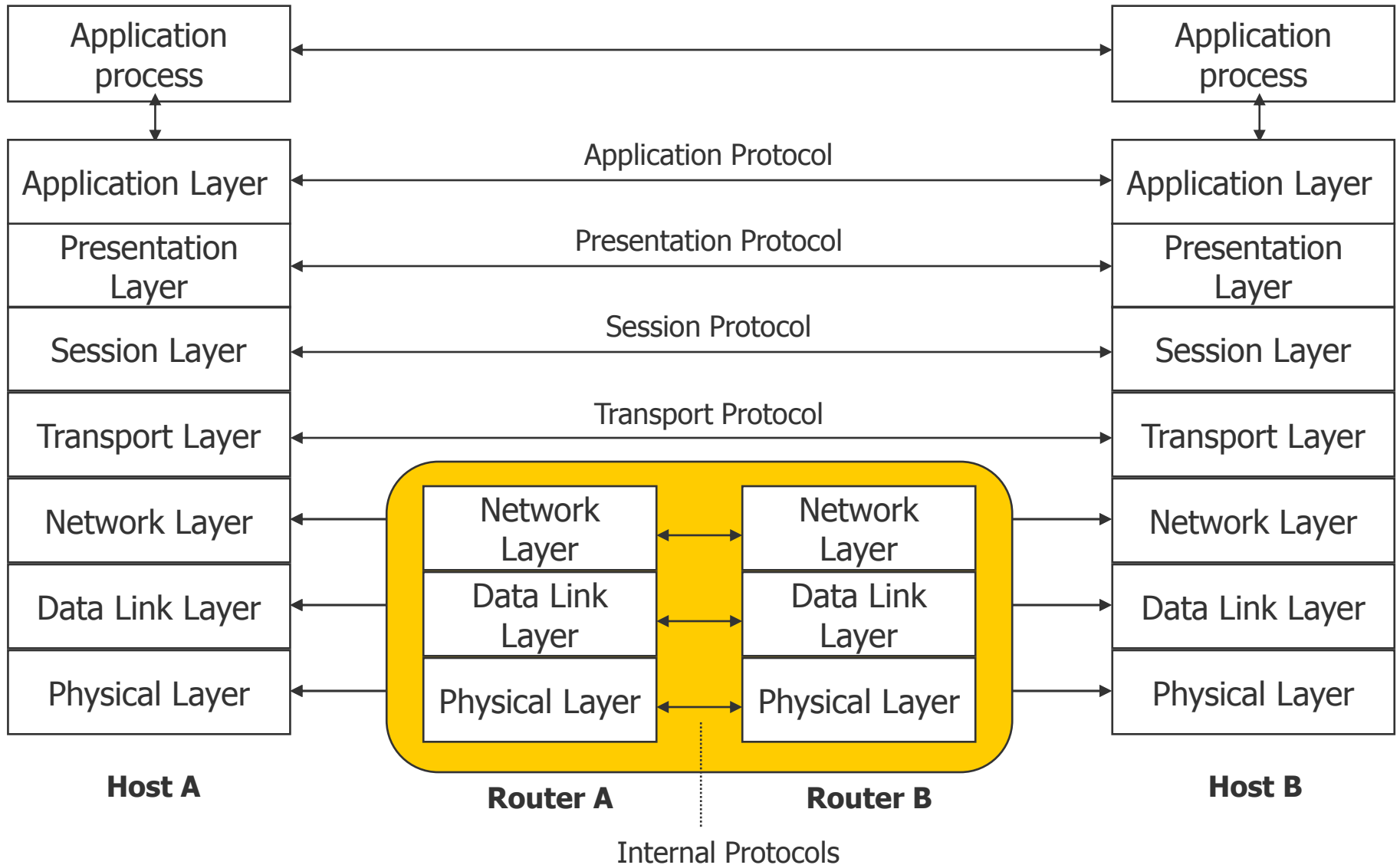

The TCP/IP Reference Model

The TCP/IP Reference Model

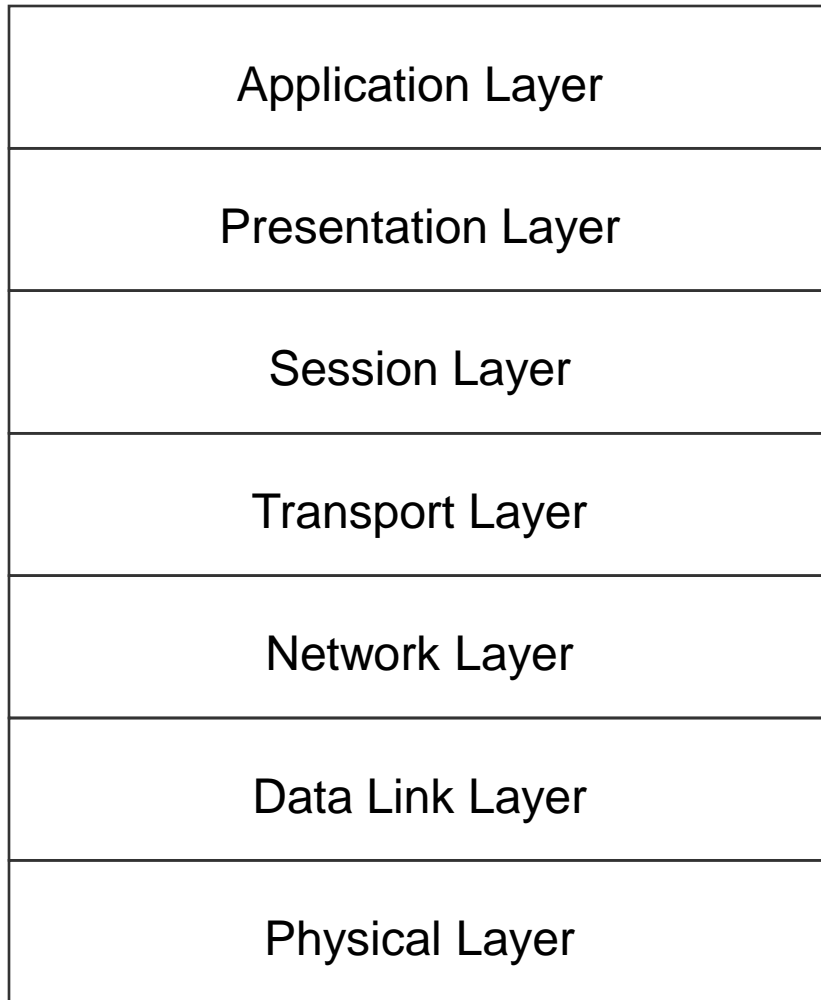

ISO/OSI

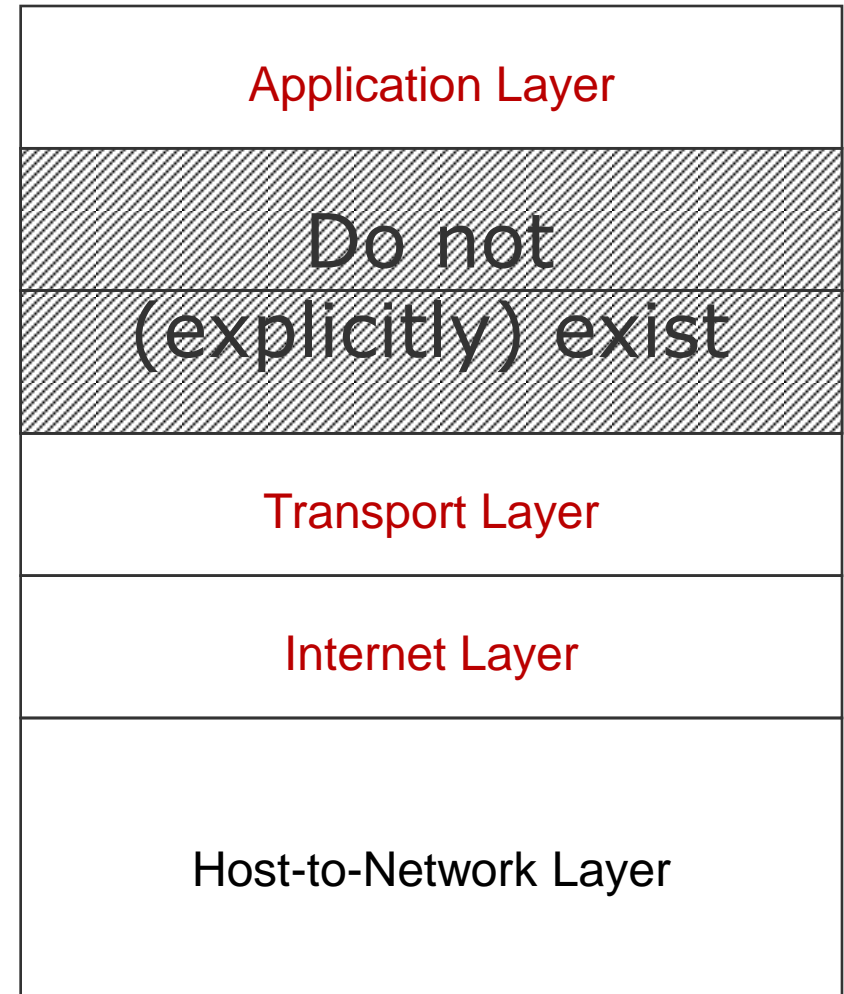

TCP/IP

The Tasks of the TCP/IP Layers

- **Host-to-Network Layer (corresponds to ISO/OSI 1-2)**

- **Not defined exactly.** The design does not matter, it is only required that a host must be connected to the network via a protocol in a way that it is able to send and receive **IP datagrams**. The protocol design is left over to other standards to cover heterogeneous networks of all kinds.

- **Internet Layer (corresponds to ISO/OSI 3)**

- The term **Internet** refers here to the interworking of different networks, therefore not to the Internet itself.
- The protocol enables communication between **hosts** over the own network borders.
 - In the Internet, the transmission is **connectionless**, i.e., data are segmented into packets which are addressed and sent independently into the network.
 - At each network border, a router takes over the forwarding of the packets. The choice of path can be dynamic, depending on the current network load.
 - As a result, single packets can get lost by overload situations or received in wrong order. Such faults are not handled, this task is left over to the transport layer (best effort).
- In contrast to ISO, only one packet format is defined, together with a connectionless protocol, the **Internet Protocol (IP)**.

The Layers of TCP/IP

- **Transport Layer (corresponds to ISO/OSI 4)**
 - This layer covers the communication between the end systems. To adapt to different applications, two protocols are defined.
 - **TCP (Transmission Control Protocol)** is a **reliable, connection-oriented** protocol to protect the transmission of a **byte stream** between two hosts.
 - The byte stream is **segmented** to fit into **IP packets**.
 - On the receiving side the packets are re-assembled in the original order with the purpose of restoring the original data (byte) stream.
 - It also includes flow control to adapt to the capabilities of the receiver and to overcome the faults caused by the connectionless IP.
 - **UDP (User Datagram Protocol)** is an **unreliable** and **connectionless** protocol (best effort). No error correction is integrated, thus the transmission is used when the speed of the data transmission is more important than the reliability (speech, video).
- **Application Layer (corresponds to ISO/OSI 7)**
 - This layer defines common communication services. This comprises TELNET (remote work on another computer), FTP (file transfer), SMTP (electronic mail), DNS ("phonebook" for the Internet), HTTP (used for World Wide Web), etc.

The TCP/IP Reference Model

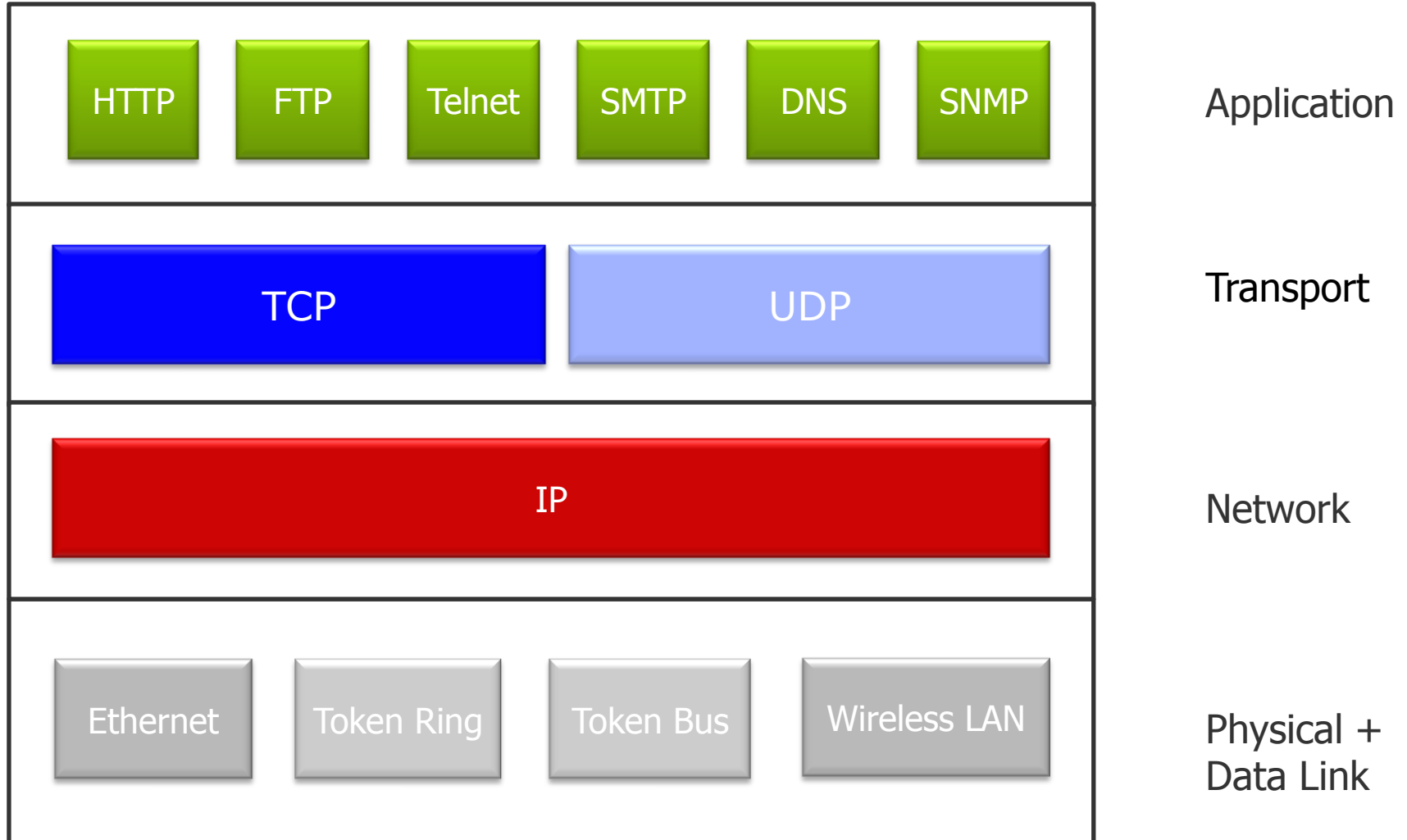



OSI vs. TCP/IP

OSI vs. TCP/IP

- Time
 - The TCP/IP protocols were already widely used before OSI had finished the standardization activities.
- Freedom from obligation
 - A “reference model” like OSI is free from obligation. It only defines what is to be done, but not how to do it.
 - ➔ incompatibility of products.
- Complicatedness
 - Very high and partly unneeded expense in the OSI specification (thousands of pages of specification descriptions).
 - By the wish to consider all special cases, lots of options were included, making the products lavish, unhandy, and far too expensive
 - ➔ “The option is the enemy of the standard”!

OSI vs. TCP/IP

- Political reasons
 - OSI was dominated too much by Europe – especially from the national telecommunication companies which had lucrative monopolies. The real market power was in the USA – nobody was interested in OSI over there.
- Hurriedly product implementation
 - The first OSI products were implemented too fast (driven by the success of TCP/IP protocols), were covered with faults, and had an overall low performance.
 - In contrast, the “theoretically far more unmodern” TCP/IP protocols were continuously modified and improved. They were of high quality level and successfully tested before deployment and cheap to buy due to high production numbers.



Standardization

Standardization

- Standardization is indispensable for the area-wide practical use of communication systems
 - On the national as well as the international level!
- Successful standardization is quite difficult due to:
 - Complex technical problems have to be solved
 - The involved parties, e.g., companies are often working against each other
 - Confidentially restrictions slow down/hinder the information flow
- Consequence
 - Standardization processes are very slow (due to many, often non-technical reasons).
- Two types of standards
 - De facto standards
 - De jure standards

Standardization: The Global Players

- ITU www.itu.int
International Telecommunication Union
United Nations agency for information and communication technologies
 - Radiocommunication (ITU-R)
 - Standardization (ITU-T)
 - Development (ITU-D)
- ISO www.iso.org
International Organization for Standardization (ISO Greek “uniform”)
 - ISO coordinates the standardization except from PTT
- W3C <http://www.w3.org>
 - World Wide Web Consortium: Develops standards for the web.
- DIN www.din.de
(Deutsches Institut für Normung)
 - German partner of the ISO

Standardization: ISO

● **International Organization for Standardization (ISO)**



International
Organization for
Standardization

- Organization, which is working on a volunteer basis (since 1946). www.iso.org
- Members: standards organizations of approx. 90 countries
- Deals with a **very** broad range of standards
- 200 Technical Committees (TC) for specific tasks (e.g. TC97 for computer and information processing)
- TCs consist of subcommittees comprising in turn several working groups
- Interworking with ITU-T regarding telecommunication standards, (ISO is a member of ITU-T).
- **Pioneering work of ISO regarding data communication: the ISO/OSI reference model**
 - Open Systems Interconnection (OSI)
- Notice: only the concept is pioneering, not the products developed from those concepts!

Standardization: ISO

- **WG-Meetings:**
 - Every 6-9 months to give the national organizations time to check the proposals.
 - The process of standardization
 - DP: Draft Proposal
 - DIS: Draft International Standard
 - IS: International Standard
 - A proposal gets higher in the hierarchy after an international vote and the incorporation of critics.

- ➡ A very slow process!!!

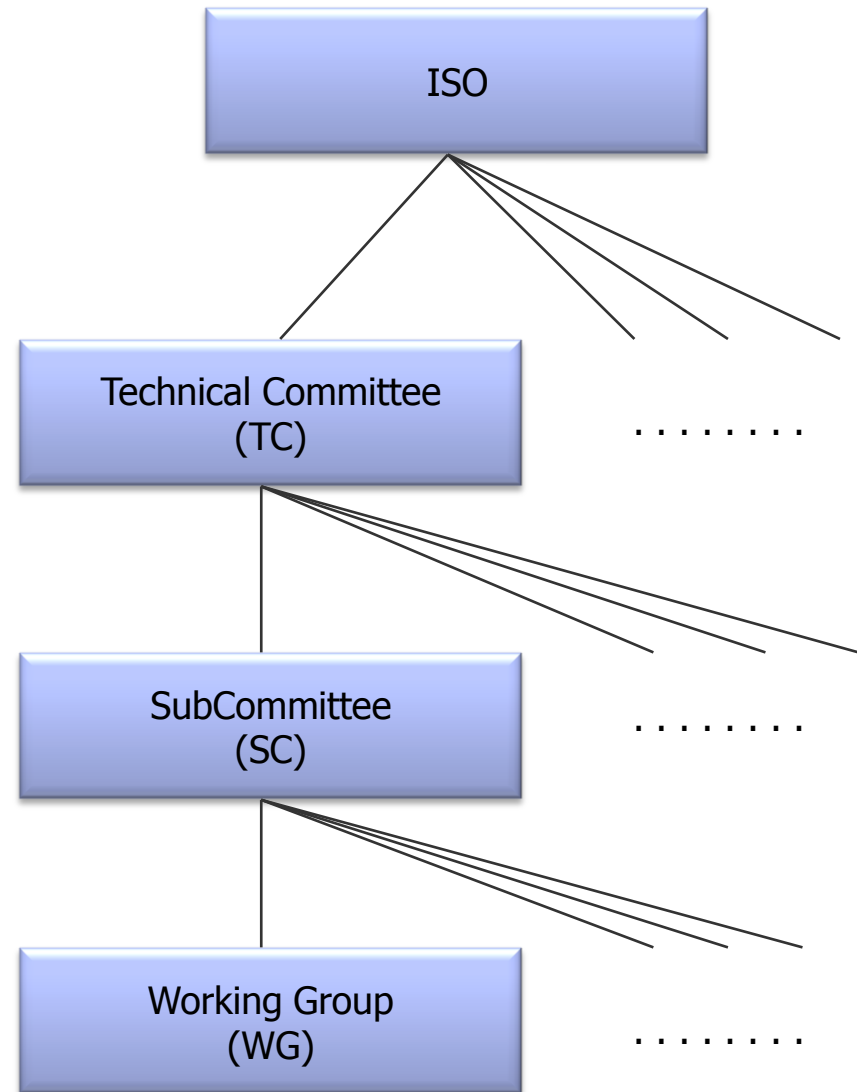

Standardization: IETF

● Internet Engineering Task Force (IETF)

- Forum for the technical coordination of the work regarding ARPANET, the precursor of the Internet (since 1986).
- Evolution to a large, open, and international community of administrators, vendors, and researchers.
- Works on evolution of the Internet architecture and the smooth operation of the Internet.
- Several working groups on Internet protocols, applications, routing, security, ...
- Standard draft proposals can become a full standard only if an implementation of the proposal is successfully tested at **two independent** locations for at **least four month**.
- Result of such a standardization process: the resounding success of the Internet protocols TCP/IP

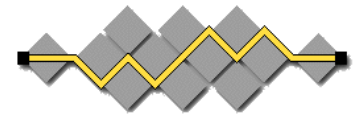
**I E T F**www.ietf.org

Standardization: Internet

- Standardization in the Internet is organized by the Internet Engineering Task Force (IETF)
 - The Internet Engineering Steering Group (IESG) steers the discussion
- Two possible outcomes:
 - RFC: Request for Comments = Standard
 - FYI: For Your Information = informal / experimental
- Proposed Standard: The idea must be completely explained in an RFC
- Draft Standard: Working implementation must have been rigorously tested by at least **two independent** sites for at least **four month**.
- [RFC 2026](#):
 - The Internet Standards Process – Revision 3

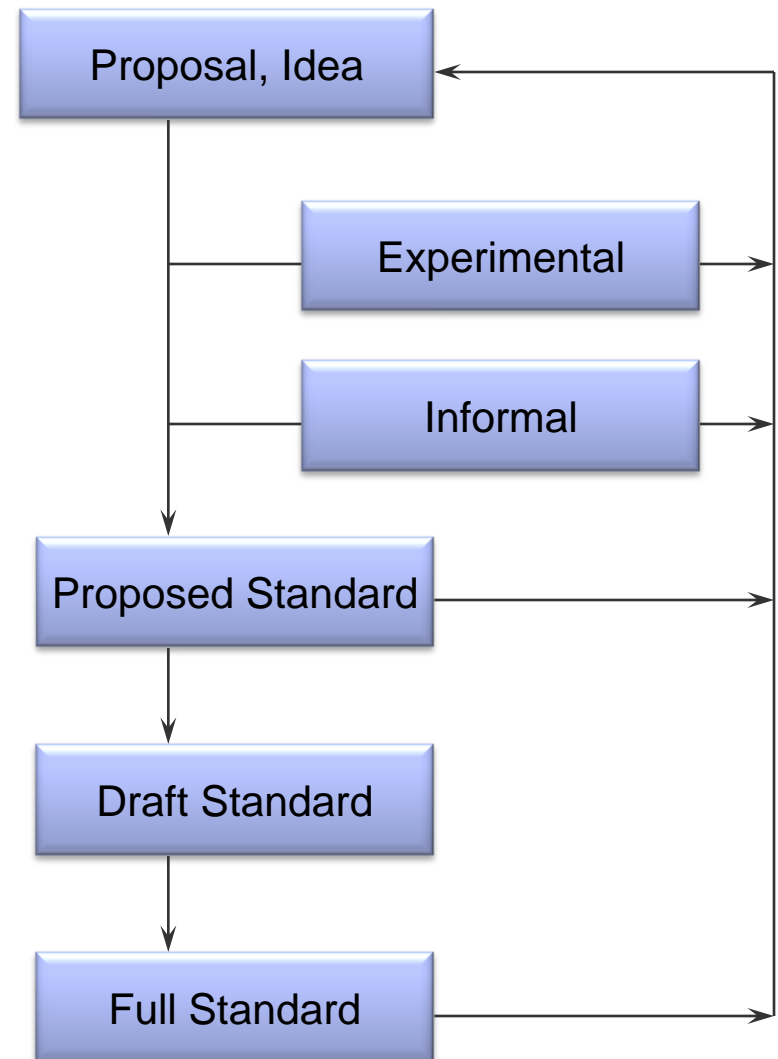

Standardization: Internet

- Well known and important RFCs
 - RFC 768 User Datagram Protocol (UDP), August 1980
 - [RFC 791](#) Internet Protocol (IP), September 1981
 - RFC 792 Internet Control Message Protocol (ICMP), September 1981
 - [RFC 793](#) Transmission Control Protocol (TCP), September 1981
 - RFC 959 File Transfer Protocol (FTP), October 1985
 - [RFC 997](#) Internet Numbers, March 1987
 - RFC 1034 Domain Names - Concepts and Facilities, November 1987
 - RFC 1035 Domain Names - Implementation and Specification, Nov. 1987
 - RFC 2205 Resource ReSerVation Protocol (RSVP) - Version 1 Functional Specification, September 1997
- Further information
 - There are ~4900 RFCs (2007), ~7000 (2012)
 - The Internet Engineering Task Force: www.ietf.org
 - Homepage of RFC Editor: www.rfc-editor.org
 - IETF Tools: <http://tools.ietf.org>



Standardization: Internet

Relationship
of all RFCs
10/2010

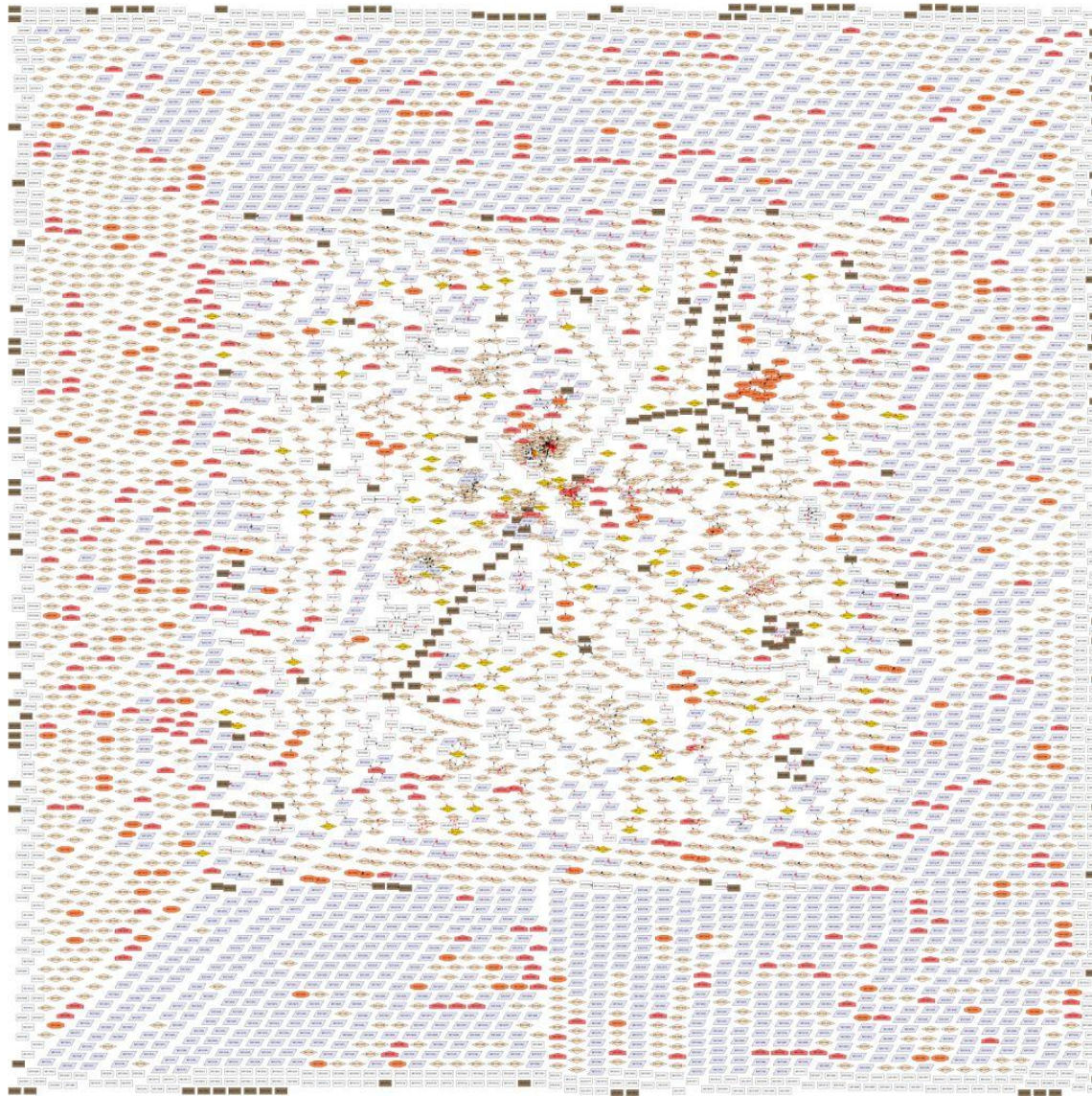

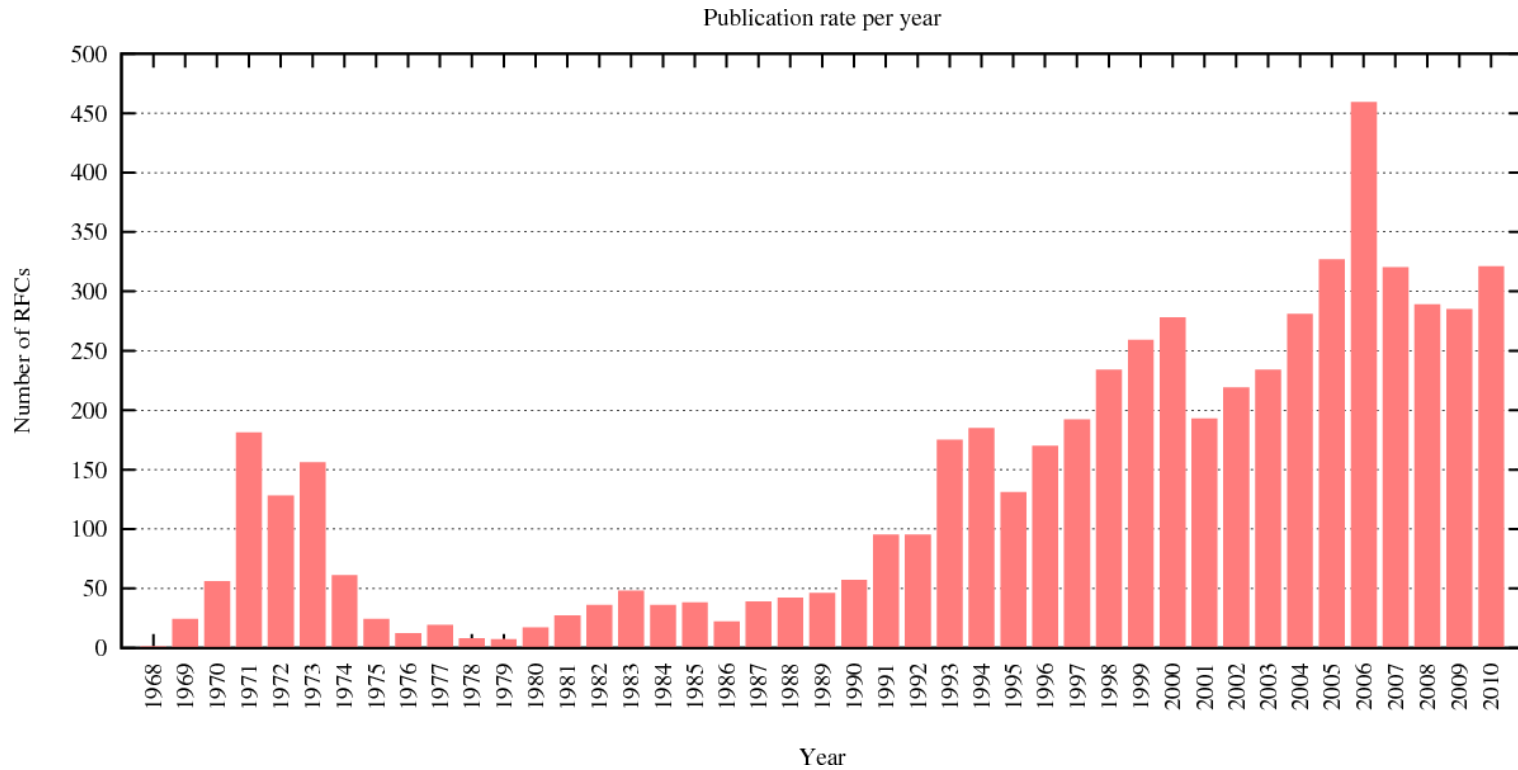

Source: <http://www.arkko.com/tools/docstats.html>

Standardization: IEEE

● Institute of Electrical and Electronic Engineers (IEEE)



- Standardization e.g. of the IEEE 802.X-Standards for Local Area Networks (www.ieee802.org, grouper.ieee.org/groups/802/dots.html)

- 802.1 Overview and Architecture of LANs
- 802.2 Logical Link Control (LLC)
- **802.3 CSMA/CD (Ethernet)**
- 802.4 Token Bus
- 802.5 Token Ring
- 802.6 DQDB (Distributed Queue Dual Bus)
- 802.7 Broadband Technical Advisory Group (BBTAG)
- 802.8 Fiber Optic Technical Advisory Group (FOTAG)
- 802.9 Integrated Services LAN (ISLAN) Interface
- 802.10 Standard for Interoperable LAN Security (SILS)
- **802.11 Wireless LAN (WLAN)**
- 802.12 Demand Priority (HP's AnyLAN)
- 802.14 Cable modems
- **802.15 Personal Area Networks (PAN, Bluetooth)**
- 802.16 Wireless MAN
- 802.17 Resilient Packet Ring
- 802.18 Radio Regulatory Technical Advisory Group (RRTAG)
- 802.19 Coexistence Technical Advisory Group
- 802.20 Mobile Broadband Wireless Access (MBWA)
- 802.21 Media Independent Handover



Evolution of Computer Networks

First Generation Computer Networks

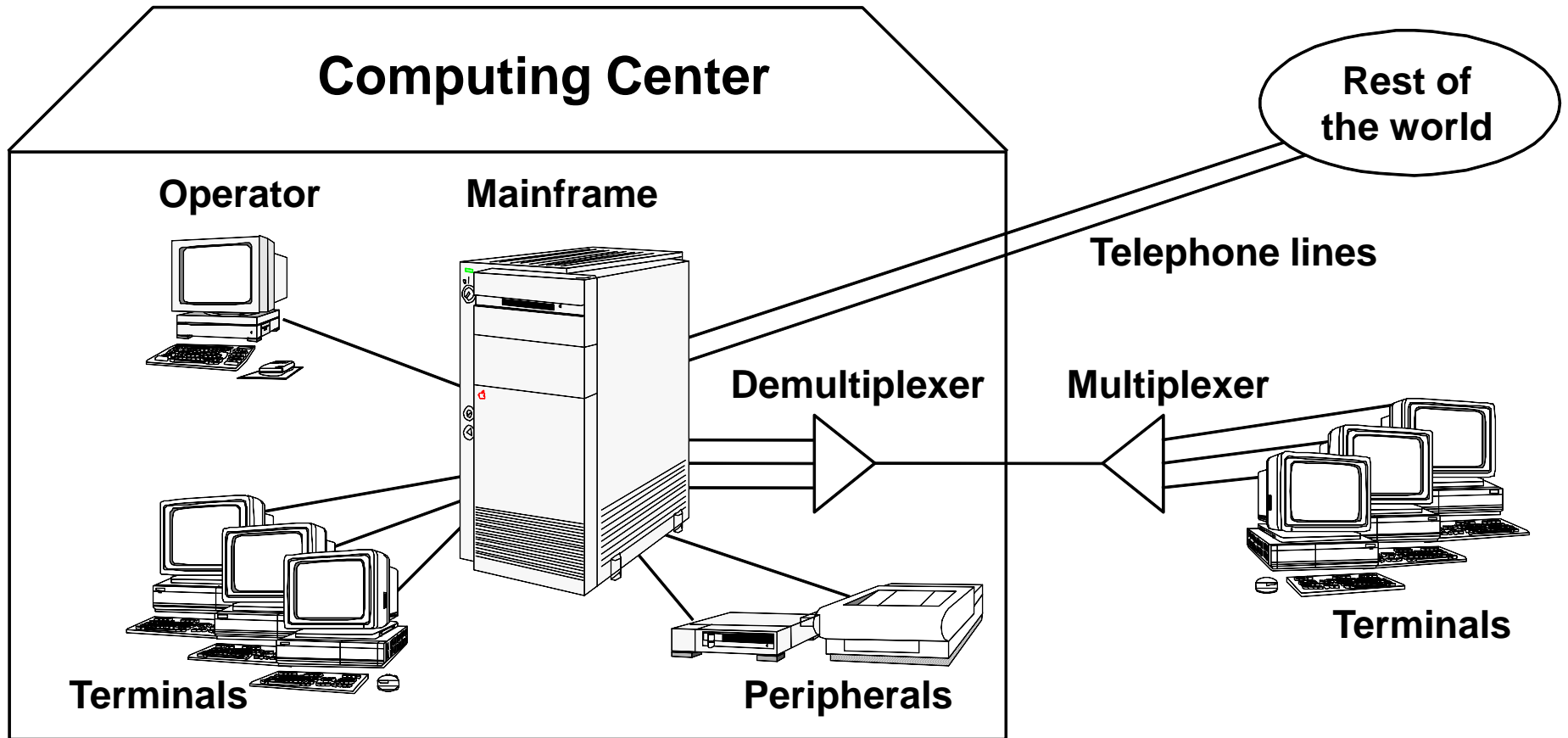



Introduction of Local Area Networks

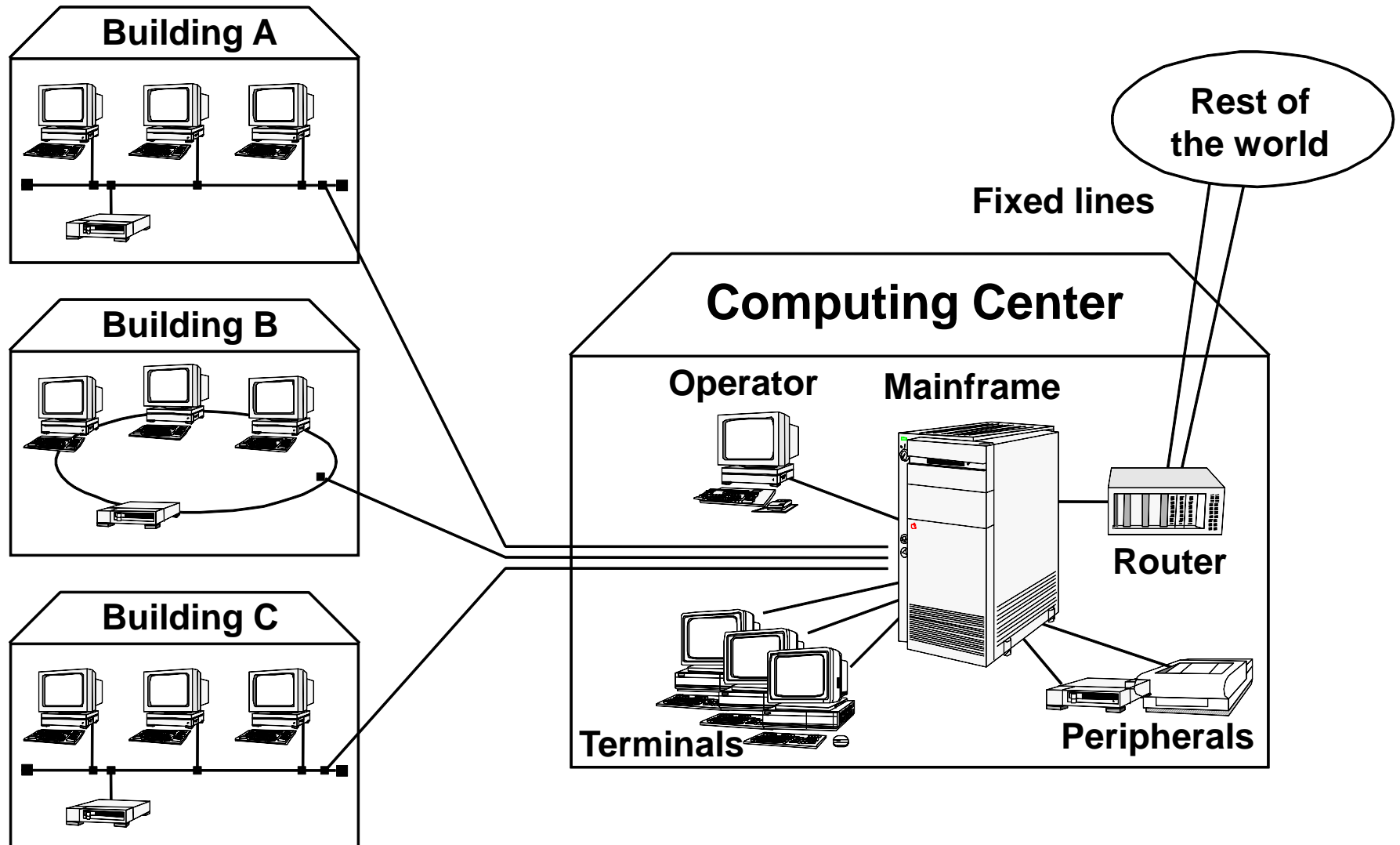



Global Networking

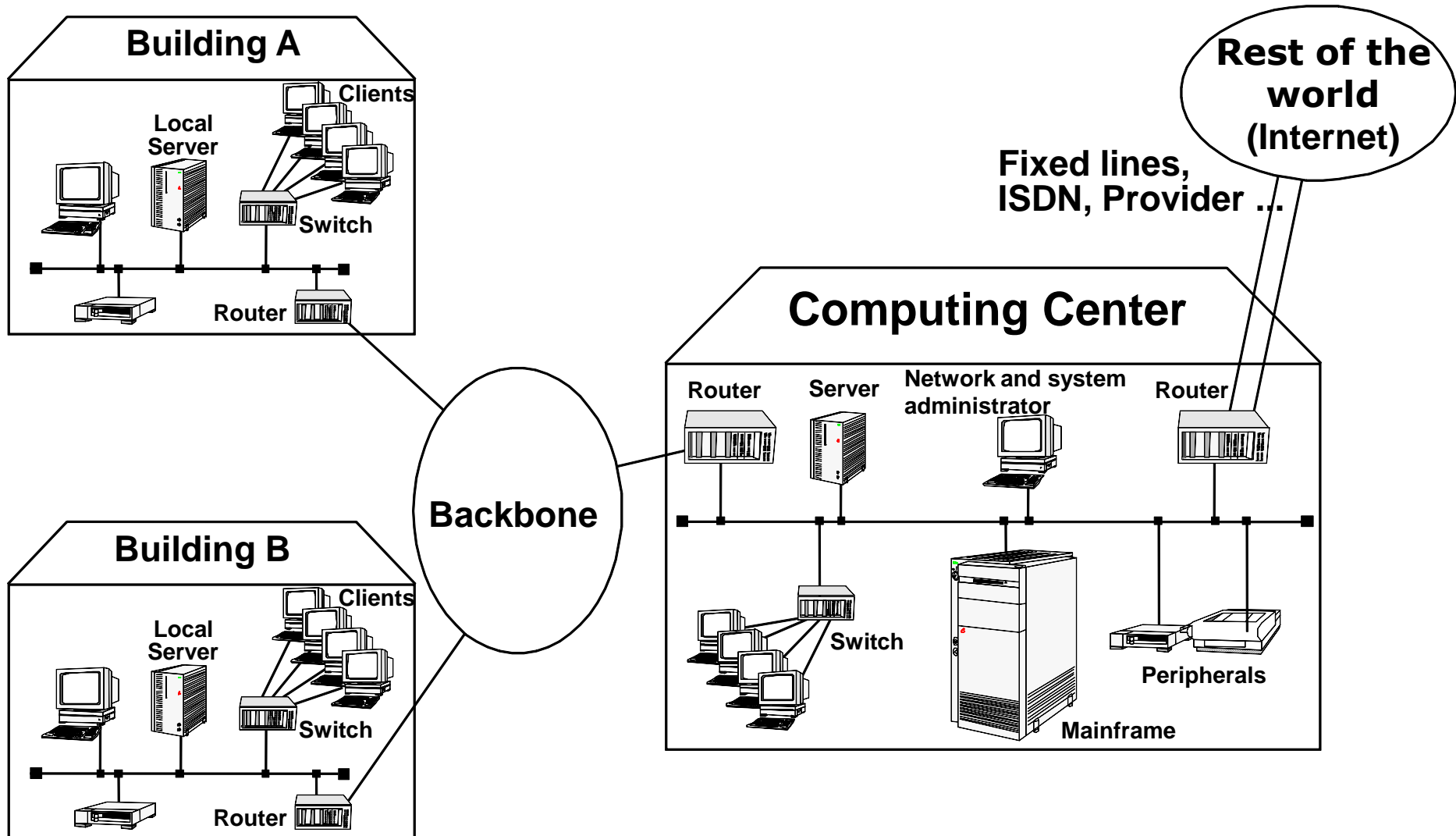



Classification of Computer Networks

Classification of Networks

Classification of networks by **distance**:

Distance	Example	
1 m	Body	}
10 m	Room	
100 m	Building	}
1 km	Campus	
10 km	Town	}
100 km	Country	
1000 km	Continent	}
10000 km	Planet	

Body/Personal Area Network (B/PAN)

Local Area Network (LAN)

Metropolitan Area Network (MAN)

Wide Area Network (WAN)

Internet

Local Area Networks

● Local Area Networks

- Communication infrastructure for a restricted geographical area (10 m up to some km)
- Usually maintained by one local organization
- Used to link PCs/Workstations/.... for exchanging information and sharing peripherals and resources
- Transmission capacity up to 1000 Mbps
- Transmission delay of a message in the range of milliseconds (~ 10 ms)
- Simple connection structures ("Simple is beautiful")

● Topologies

- Bus
- Star
- Ring
- Tree
- Meshed network

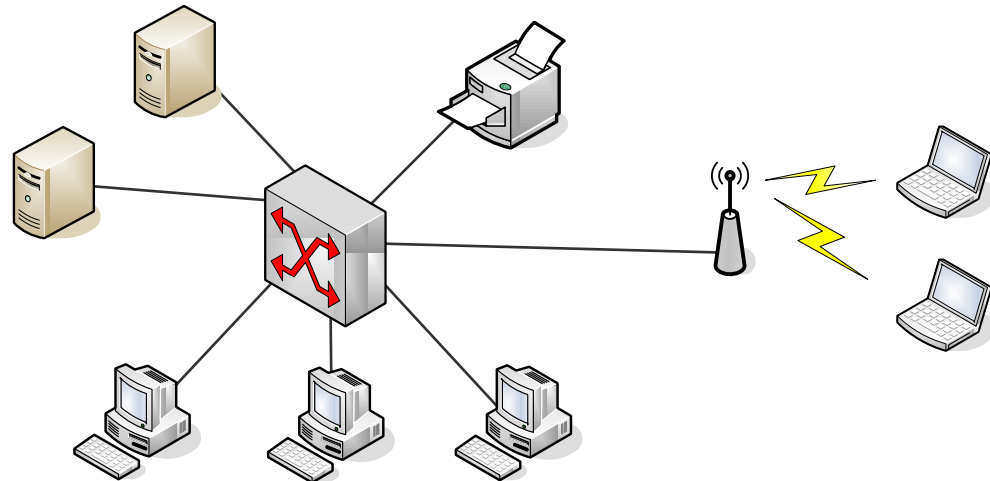

Metropolitan Area Network (MAN)

- Designed for larger distances than a LAN
 - usage e.g. in a whole town
- Similar technologies as in a LAN
- In general, only 1 or 2 cables without additional components
- Main difference to LANs: Time slots

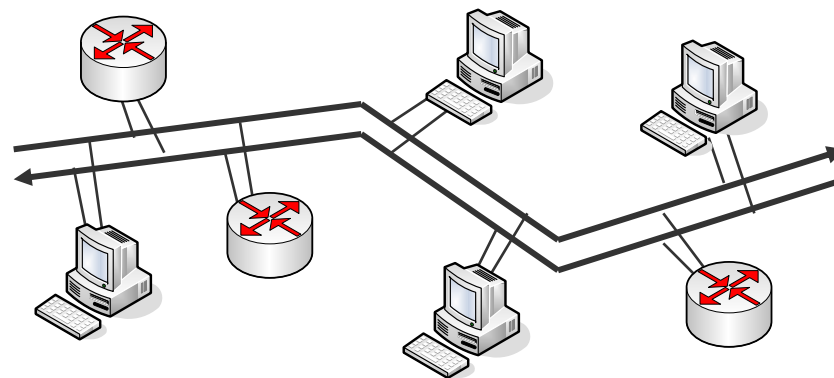

Wide Area Network (WAN)

- Bridging of any distance
- Connects LANs and MANs over large distances
- Irregular topology, based on current needs
- Consists out of stations (routers) which are connected through point-to-point links with each other
- Mostly complex interconnection of subnetworks, which are owned by independent organizations

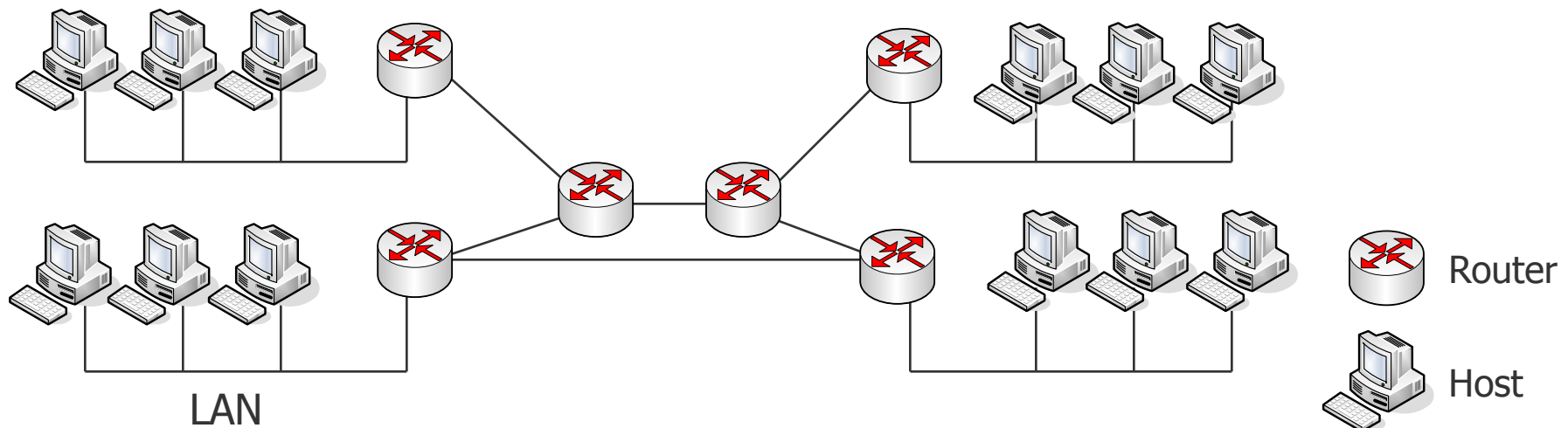

Important Terms

● Switch

- A switch has several connectors. From each connector a cable can be drawn to a computer. These computers are linked to a (small) network. The switch knows which computer is plugged in at which connector (address of the network interface card) and forwards data to a destination computer.

● Router

- A switch only knows directly connected computers. To send data to a distant computer, some other instance is needed that knows the way to the destination over several other computers or switches. Routers are used to manage global address information and forward data through networks.

● Backbone

- A backbone is a set of computers (usually routers) which are connected by point-to-point links over large distances. A backbone serves for covering a large region with a communication network which can interconnect (small) local networks of single institutions.

Classification of Networks

- Classification of networks by communication technique

1. Point-to-Point Network

- A pair of computers is directly connected by one cable



2. Broadcast Network

- One-to-all (e.g.: radio, television)
- All connected stations share one transmission channel
- To ensure that the data are received by the destination, they are marked with the address of the destination computer
- Data are being packed into packets with the unicast address of the destination
- Every computer checks each received packet for its address. Only the destination computer processes the data, all others simply delete them
- To address all connected stations at once, so-called broadcast addresses are used

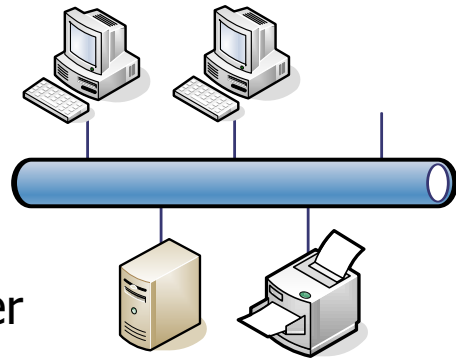

Networks

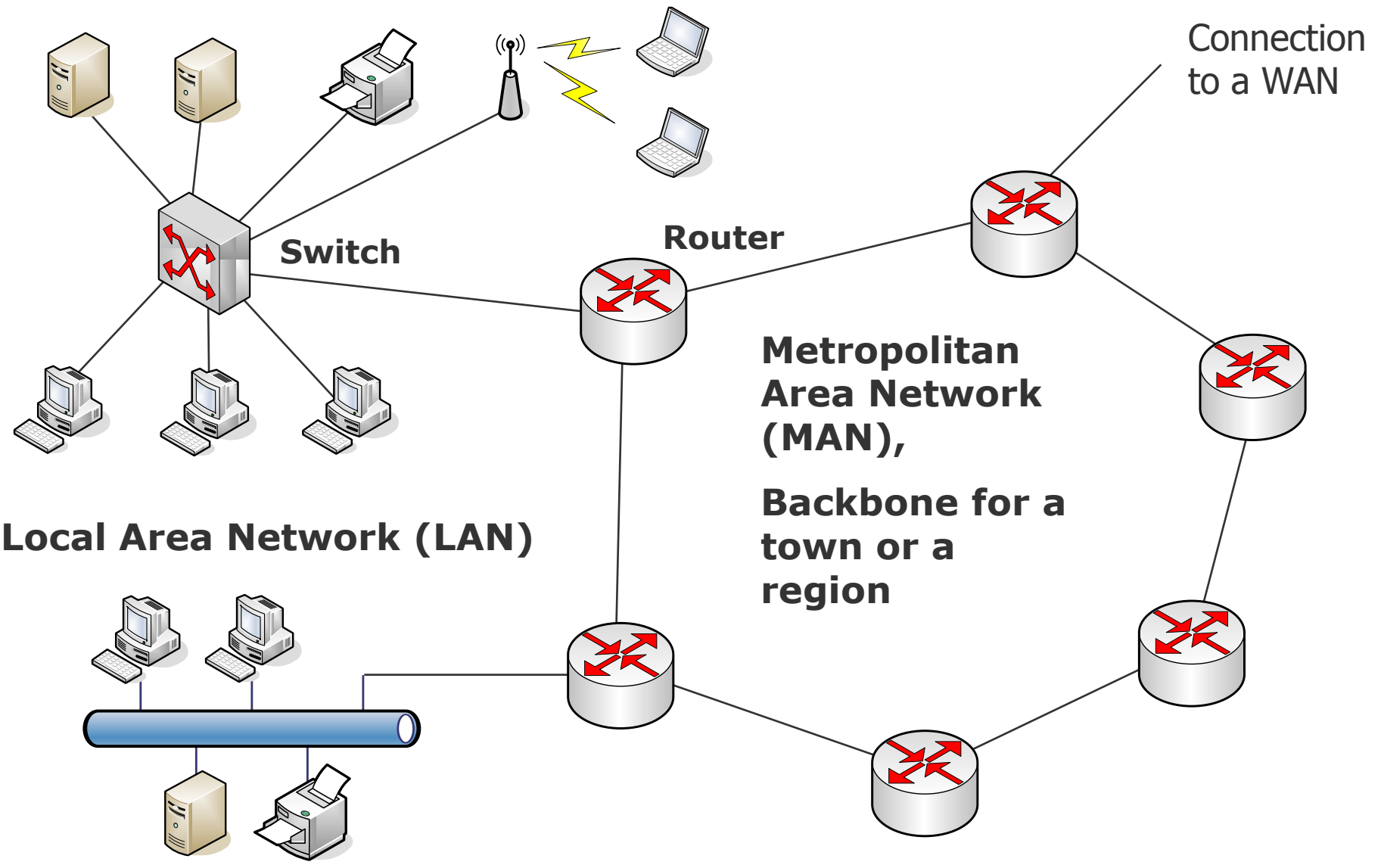



Networks

Backbone in Germany (till end of 2005)

- 27 nodes
- █ 10 Gbps
- 2,4 Gbps
- 2,4 Gbps

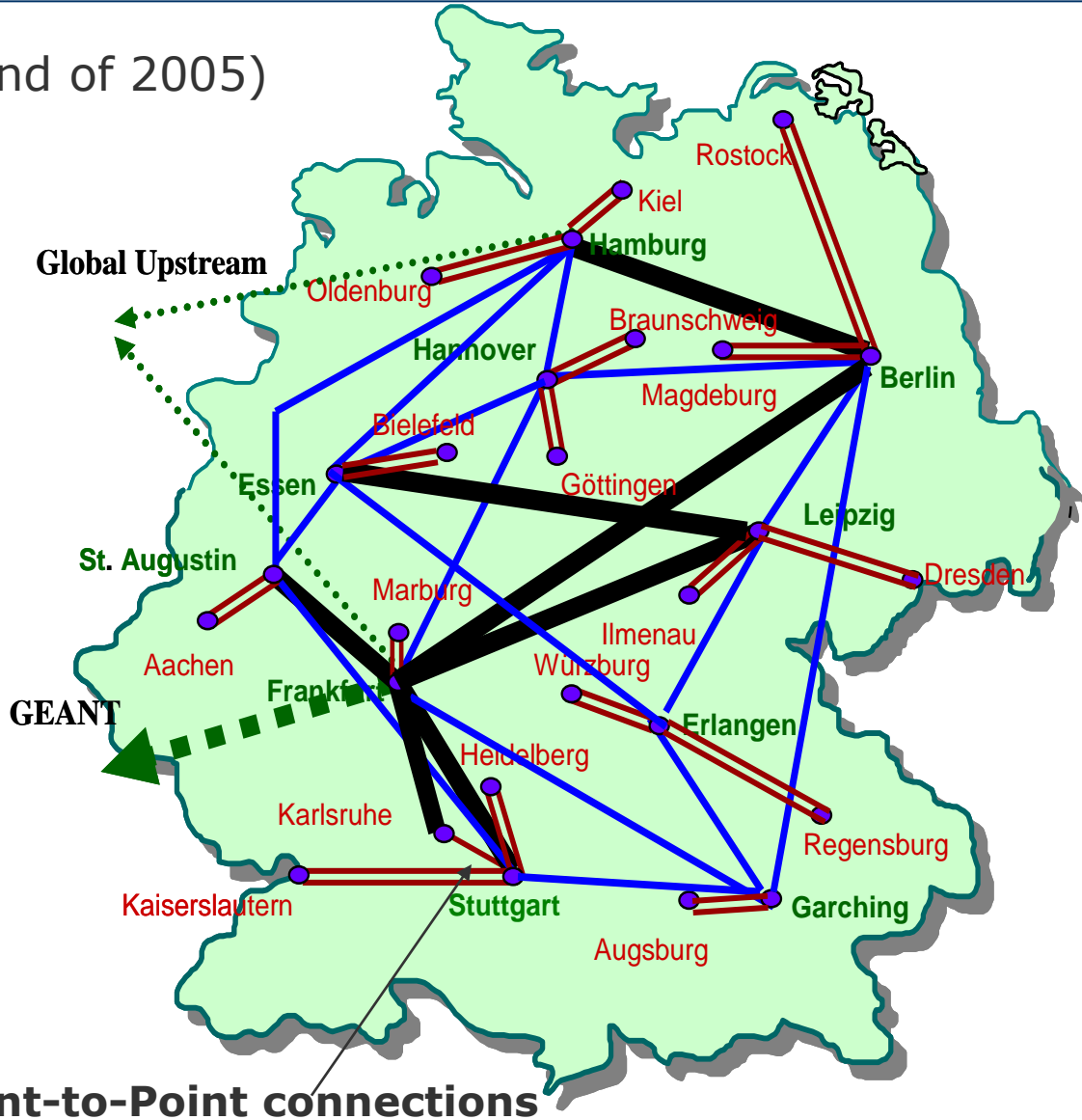

Networks

- Research backbone in Germany
 - Since 2006 X-WIN
 - Connected to the European Backbone GÉANT
 - More than 50 nodes
 - Capacities
 - 100Mbps
 - 200Mbps
 - 1Gbps
 - 10Gbps

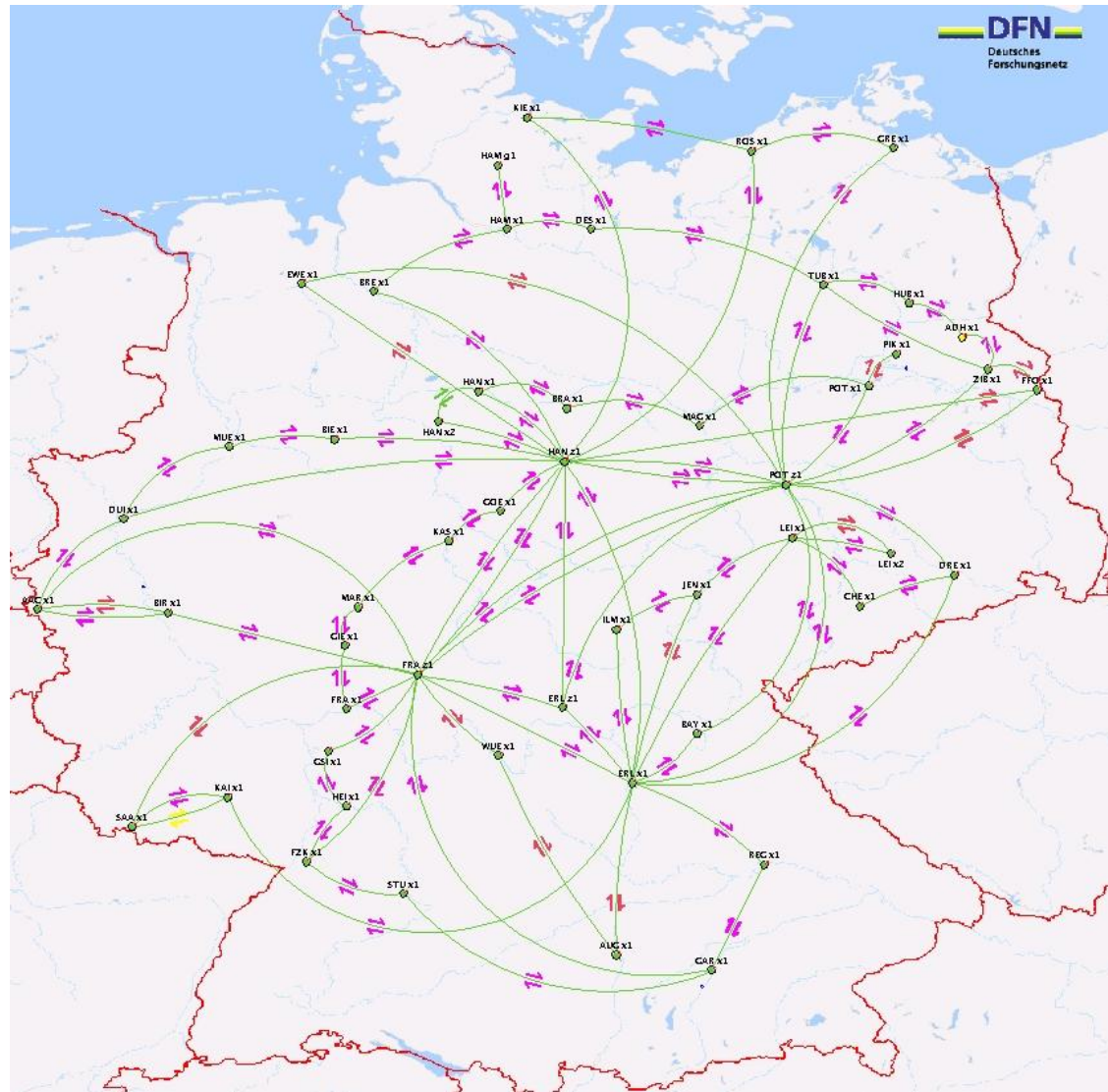



Networks

Central node Frankfurt – connection to the European research network Géant.

Also in Frankfurt and Hamburg: intercontinental connections.

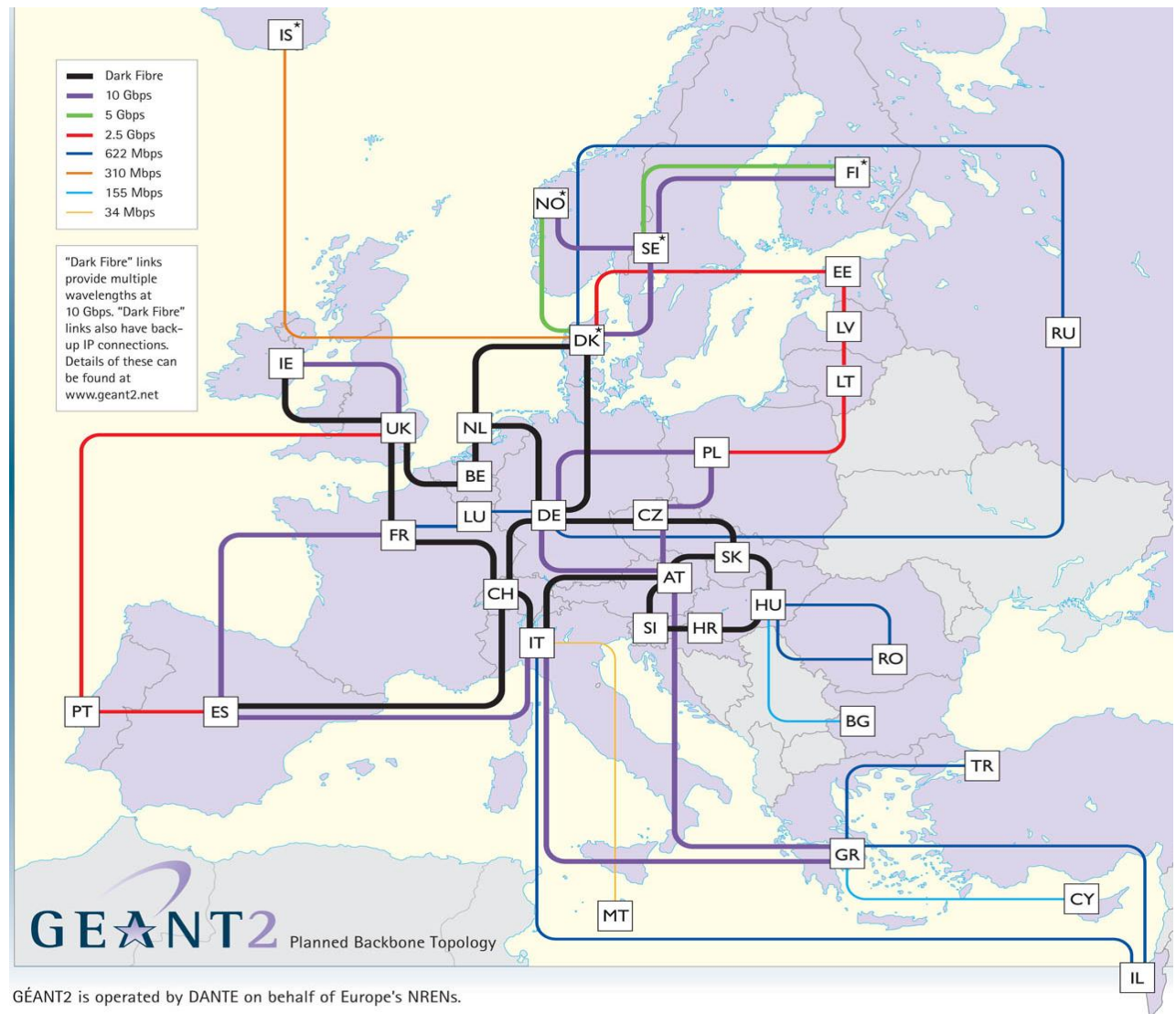

Summary

- Computer networks have many applications
 - Sharing of resources
 - Exchange of information
- Computer networks are complex and consists of two parts
 - Software
 - Hardware
- Model of layers is applied to simplify the complexity
 - ISO/OSI
 - TCP/IP
- There are many global players in computer networking
 - Standardization
- Computer networks
 - Different kinds of computer networks exist
 - Classification based on distance
 - Classification based on communication principle

Data Communication

Data Communication

Data communication is the **processing** and the **transport** of digital data over connections between computers and/or other devices.

Data communication comprises two topical areas.

1. Computer Networks

- How to connect several computers?
- Which media can be used for data transport?
- How to represent digital data on the medium?
- How to coordinate the access of several computers to the medium?

2. Communication Protocols

- Design of uniform data units for transfer
- How to achieve a reliable and efficient transfer?

Data Communication

