

CAN controller interface**PCA82C250****FEATURES**

- Fully compatible with the "ISO/DIS 11898" standard
- High speed (up to 1 Mbaud)
- Bus lines protected against transients in an automotive environment
- Slope control to reduce radio frequency interference (RFI)
- Differential receiver with wide common-mode range for high immunity against electron magnetic interference (EMI)
- Thermally protected
- Short-circuit proof to battery and ground
- Low current standby mode
- An unpowered node does not disturb the bus lines
- At least 110 nodes can be connected.

APPLICATIONS

- High-speed applications (up to 1 Mbaud) in cars.

GENERAL DESCRIPTION

The PCA82C250 is the interface between the CAN protocol controller and the physical bus. The device provides differential transmit capability to the bus and differential receive capability to the CAN controller.

QUICK REFERENCE DATA

SYMBOL	PARAMETER	CONDITIONS	MIN.	MAX.	UNIT
V_{CC}	supply voltage		4.5	5.5	V
I_{CC}	supply current		–	170	μ A
$1/t_{bit}$	maximum transmission speed	non-return-to-zero	1	–	Mbaud
V_{CAN}	CANH, CANL input/output voltage		–8	+18	V
ΔV	differential bus voltage		1.5	3.0	V
t_{pd}	propagation delay	high-speed mode	–	50	ns
T_{amb}	operating ambient temperature		–40	+125	$^{\circ}$ C

ORDERING INFORMATION

EXTENDED TYPE NUMBER	PACKAGE			
	PINS	PIN POSITION	MATERIAL	CODE
PCA82C250	8	DIL8	plastic	SOT97A
PCA82C250T	8	SO8	plastic	SOT96A

CAN controller interface

PCA82C250

BLOCK DIAGRAM

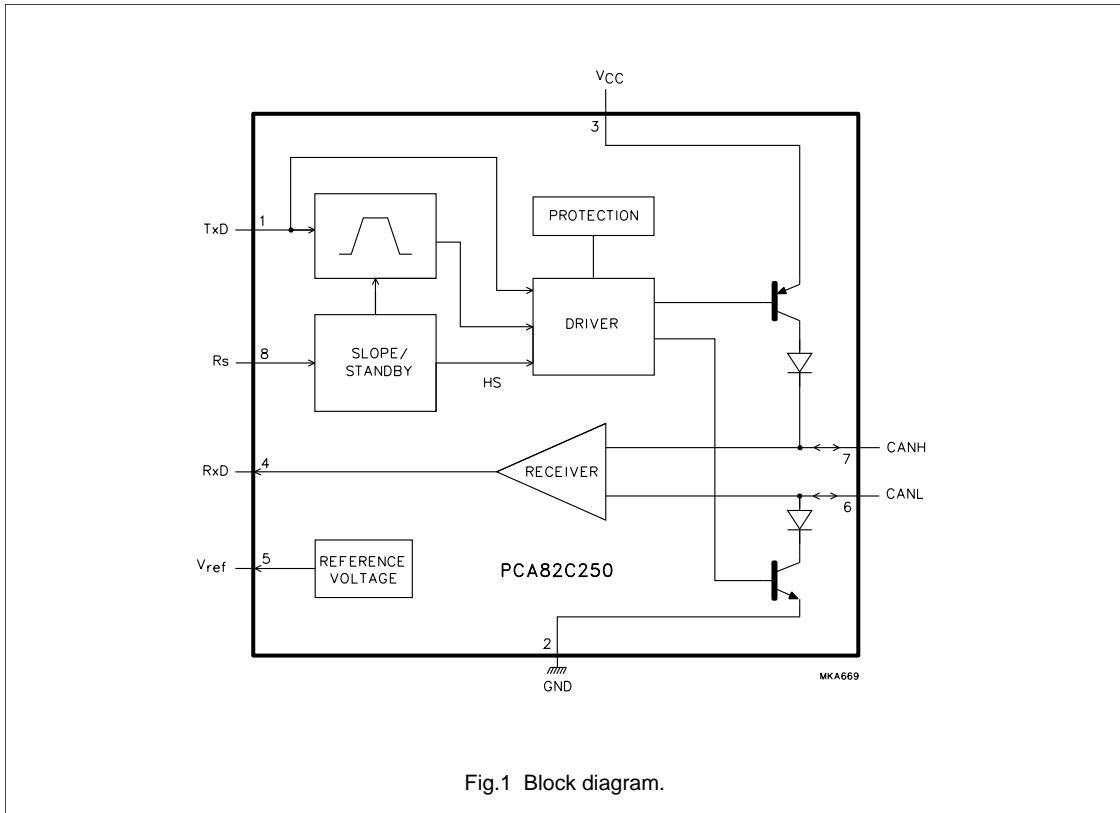

Fig.1 Block diagram.

PINNING

SYMBOL	PIN	DESCRIPTION
TxD	1	transmit data input
GND	2	ground
V _{CC}	3	supply voltage
RxD	4	receive data output
V _{ref}	5	reference voltage output
CANL	6	LOW level CAN voltage input/output
CANH	7	HIGH level CAN voltage input/output
Rs	8	slope resistor input

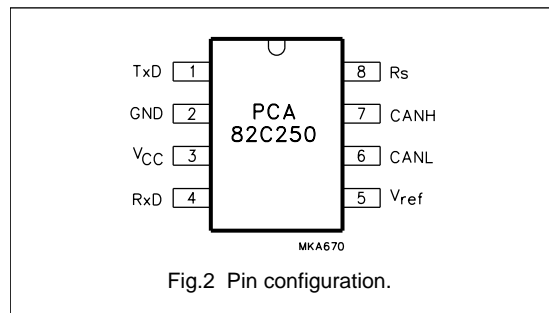

Fig.2 Pin configuration.

CAN controller interface

PCA82C250

FUNCTIONAL DESCRIPTION

The PCA82C250 is the interface between the CAN protocol controller and the physical bus. It is primarily intended for high-speed applications (up to 1 Mbaud) in cars. The device provides differential transmit capability to the bus and differential receive capability to the CAN controller. It is fully compatible with the "ISO/DIS 11898" standard.

A current limiting circuit protects the transmitter output stage against short-circuit to positive and negative battery voltage. Although the power dissipation is increased during this fault condition, this feature will prevent destruction of the transmitter output stage.

If the junction temperature exceeds a value of approximately 160 °C, the limiting current of both transmitter outputs is decreased. Because the transmitter is responsible for the major part of the power dissipation, this will result in a reduced power dissipation and hence a lower chip temperature. All other parts of the IC will remain in operation. The thermal protection is particularly needed when a bus line is short-circuited.

The CANH and CANL lines are also protected against electrical transients which may occur in an automotive environment. Pin 8 (Rs) allows three different modes of operation to be selected: high-speed, slope control or standby.

For high-speed operation, the transmitter output transistors are simply switched on and off as fast as possible. In this mode, no measures are taken to limit the rise and fall slope. Use of a shielded cable is recommended to avoid RFI problems. The high-speed mode is selected by connecting pin 8 to ground.

For lower speeds or shorter bus length, an unshielded twisted pair or a parallel pair of wires can be used for the bus. To reduce RFI, the rise and fall slope should be limited. The rise and fall slope can be programmed with a resistor connected from pin 8 to ground. The slope is proportional to the current output at pin 8.

If a HIGH level is applied to pin 8, the circuit enters a low current standby mode. In this mode, the transmitter is switched off and the receiver is switched to a low current. If dominant bits are detected (differential bus voltage >0.9 V), RxD will be switched to a LOW level. The microcontroller should react to this condition by switching the transceiver back to normal operation (via pin 8). Because the receiver is slow in standby mode, the first message will be lost.

Table 1 Truth table of CAN transceiver.

SUPPLY	TxD	CANH	CANL	BUS STATE	RxD
4.5 to 5.5 V	0	HIGH	LOW	dominant	0
4.5 to 5.5 V	1 (or floating)	floating	floating	recessive	1
<2 V (not powered)	X	floating	floating	recessive	X
$2\text{ V} < V_{CC} < 4.5\text{ V}$	$>0.75V_{CC}$	floating	floating	recessive	X
$2\text{ V} < V_{CC} < 4.5\text{ V}$	X	floating if $V_{Rs} > 0.75V_{CC}$	floating if $V_{Rs} > 0.75V_{CC}$	recessive	X

Table 2 Rs (pin 8) summary.

CONDITION FORCED AT Rs	MODE	RESULTING VOLTAGE OR CURRENT AT Rs
$V_{Rs} > 0.75V_{CC}$	standby	$I_{Rs} < 10\ \mu\text{A} $
$10\ \mu\text{A} < I_{Rs} < 200\ \mu\text{A}$	slope control	$0.4V_{CC} < V_{Rs} < 0.6V_{CC}$
$V_{Rs} < 0.3V_{CC}$	high-speed	$I_{Rs} < -500\ \mu\text{A}$

CAN controller interface

PCA82C250

LIMITING VALUES

In accordance with the Absolute Maximum Rating System (IEC 134). All voltages are referenced to pin 2; positive input current.

SYMBOL	PARAMETER	CONDITIONS	MIN.	MAX.	UNIT
V_{CC}	supply voltage		-0.3	+9.0	V
V_n	DC voltage at pins 1, 4, 5 and 8		-0.3	$V_{CC} + 0.3$	V
$V_{6,7}$	DC voltage at pins 6 and 7	$0\text{ V} < V_{CC} < 5.5\text{ V}$; no time limit	-8.0	+18.0	V
V_{trt}	transient voltage at pins 6 and 7	see Fig.8	-150	+100	V
T_{stg}	storage temperature		-55	+150	°C
T_{amb}	operating ambient temperature		-40	+125	°C
T_{vj}	virtual junction temperature	note 1	-40	+150	°C

Note

1. In accordance with "IEC 747-1".

An alternative definition of virtual junction temperature T_{vj} is: $T_{vj} = T_{amb} + P_d \times R_{th\ vj-amb}$,
where $R_{th\ vj-amb}$ is a fixed value to be used for the calculation of T_{vj} .

The rating for T_{vj} limits the allowable combinations of power dissipation (P_d) and ambient temperature (T_{amb}).

HANDLING

Classification A: human body model; C = 100 pF; R = 1500 Ω ; V = ± 2000 V.

Classification B: machine model; C = 200 pF; R = 0 Ω ; V = ± 200 V.

QUALITY SPECIFICATION

Quality specification "SNW-FQ-611 part E" is applicable and can be found in the "Quality reference pocket-book" (ordering number 9398 510 34011).

THERMAL RESISTANCE

SYMBOL	PARAMETER	THERMAL RESISTANCE
$R_{th\ j-a}$	from junction to ambient in free air	
	PCA82C250	100 K/W
	PCA82C250T	160 K/W

CAN controller interface

PCA82C250

CHARACTERISTICS

$V_{CC} = 4.5$ to 5.5 V; $T_{amb} = -40$ to $+25$ °C; $R_L = 60$ Ω ; $I_B > -10$ μ A; unless otherwise specified.

All voltages referenced to ground (pin 2); positive input current; all parameters are guaranteed over the ambient temperature range by design, but only 100% tested at $+25$ °C.

SYMBOL	PARAMETER	CONDITIONS	MIN.	TYP.	MAX.	UNIT
Supply						
I_3	supply current	dominant; $V_1 = 1$ V	–	–	70	mA
		recessive; $V_1 = 4$ V; $R_8 = 47$ k Ω	–	–	14	mA
		recessive; $V_1 = 4$ V; $V_8 = 1$ V	–	–	18	mA
		standby; $T_{amb} < 90$ °C; note 1	–	100	170	μ A
DC bus transmitter						
V_{IH}	HIGH level input voltage	output recessive	$0.7V_{CC}$	–	$V_{CC} + 0.3$	V
V_{IL}	LOW level input voltage	output dominant	–0.3	–	$0.3V_{CC}$	V
I_{IH}	HIGH level input current	$V_1 = 4$ V	–200	–	+30	μ A
I_{IL}	LOW level input voltage	$V_1 = 1$ V	100	–	600	μ A
$V_{6,7}$	recessive bus voltage	$V_1 = 4$ V; no load	2.0	–	3.0	V
I_{LO}	off-state output leakage current	-2 V $< (V_6, V_7) < 7$ V	–2	–	+1	mA
		-2 V $< (V_6, V_7) < 18$ V	–5	–	+12	mA
V_7	CANH output voltage	$V_1 = 1$ V	2.75	–	4.5	V
V_6	CANL output voltage	$V_1 = 1$ V	0.5	–	2.25	V
$\Delta V_{6,7}$	difference between output voltage at pins 6 and 7	$V_1 = 1$ V	1.5	–	3.0	V
		$V_1 = 1$ V; $R_L = 45$ Ω ; $V_{CC} \geq 4.9$ V	1.5	–	–	V
		$V_1 = 4$ V; no load	–500	–	+50	mA
I_{sc7}	short-circuit CANH current	$V_7 = -5$ V; $V_{CC} \leq 5$ V	–	–	105	mA
		$V_7 = -5$ V; $V_{CC} = 5.5$ V	–	–	120	mA
I_{sc6}	short-circuit CANL current	$V_6 = +18$ V	–	–	160	mA
DC bus receiver: $V_1 = 4$ V; pins 6 and 7 externally driven; -2 V $< (V_6, V_7) < 7$ V; unless otherwise specified						
$V_{diff(r)}$	differential input voltage (recessive)		–1.0	–	0.5	V
		-7 V $< (V_6, V_7) < 12$ V; not standby mode	–1.0	–	0.4	V
$V_{diff(d)}$	differential input voltage (dominant)		0.9	–	5.0	V
		-7 V $< (V_6, V_7) < 12$ V; not standby mode	1.0	–	5.0	V
$V_{diff(hys)}$	differential input hysteresis	see Fig.5	–	150	–	mV
V_{OH}	HIGH level output voltage (pin 4)	$I_4 = -100$ μ A	$0.8V_{CC}$	–	V_{CC}	V
V_{OL}	LOW level output voltage (pin 4)	$I_4 = 1$ mA	0	–	$0.2V_{CC}$	V
		$I_4 = 10$ mA	0	–	1.5	V
R_i	CANH, CANL input resistance		5	–	25	k Ω

CAN controller interface

PCA82C250

SYMBOL	PARAMETER	CONDITIONS	MIN.	TYP.	MAX.	UNIT
R_{diff}	differential input resistance		20	–	100	k Ω
C_i	CANH, CANL input capacitance		–	–	20	pF
C_{diff}	differential input capacitance		–	–	10	pF
Reference output						
V_{ref}	reference output voltage	$V_8 = 1\text{ V};$ $-50\text{ }\mu\text{A} < I_5 < 50\text{ }\mu\text{A}$	$0.45V_{CC}$	–	$0.55V_{CC}$	V
		$V_8 = 4\text{ V};$ $-50\text{ }\mu\text{A} < I_5 < 50\text{ }\mu\text{A}$	$0.4V_{CC}$	–	$0.6V_{CC}$	V
Timing (see Figs 4, 6 and 7)						
t_{bit}	minimum bit time	$V_8 = 1\text{ V}$	–	–	1	μs
t_{onTxD}	delay TxD to bus active	$V_8 = 1\text{ V}$	–	–	50	ns
t_{offTxD}	delay TxD to bus inactive	$V_8 = 1\text{ V}$	–	40	80	ns
t_{onRxD}	delay TxD to receiver active	$V_8 = 1\text{ V}$	–	55	120	ns
t_{offRxD}	delay TxD to receiver inactive	$V_8 = 1\text{ V}; V_{CC} < 5.1\text{ V};$ $T_{amb} < +85\text{ }^\circ\text{C}$	–	82	150	ns
		$V_8 = 1\text{ V}; V_{CC} < 5.1\text{ V};$ $T_{amb} < +125\text{ }^\circ\text{C}$	–	82	170	ns
		$V_8 = 1\text{ V}; V_{CC} < 5.5\text{ V};$ $T_{amb} < +85\text{ }^\circ\text{C}$	–	90	170	ns
		$V_8 = 1\text{ V}; V_{CC} < 5.5\text{ V};$ $T_{amb} < +125\text{ }^\circ\text{C}$	–	90	190	ns
t_{onRxD}	delay TxD to receiver active	$R_8 = 47\text{ k}\Omega$	–	390	520	ns
		$R_8 = 24\text{ k}\Omega$	–	260	320	ns
t_{offRxD}	delay TxD to receiver inactive	$R_8 = 47\text{ k}\Omega$	–	260	450	ns
		$R_8 = 24\text{ k}\Omega$	–	210	320	ns
$ SR $	differential output voltage slew rate	$R_8 = 47\text{ k}\Omega$	–	14	–	V/ μs
t_{WAKE}	wake-up time from standby (via pin 8)		–	–	20	μs
t_{dRxDL}	bus dominant to RxD LOW	$V_8 = 4\text{ V};$ standby mode	–	–	3	μs
Standby/slope control (pin 8)						
V_8	input voltage for high-speed		–	–	$0.3V_{CC}$	V
I_8	input current for high-speed	$V_8 = 1\text{ V}$	–	–	–500	μA
V_{stb}	input voltage for standby mode		$0.75V_{CC}$	–	–	V
I_{slope}	slope control mode current		–10	–	–200	μA
V_{slope}	slope control mode voltage		$0.4V_{CC}$	–	$0.6V_{CC}$	V

Note

- $I_1 = I_4 = I_5 = 0\text{ mA}; 0 < V_7; V_6 < V_{CC}; V_8 = V_{CC}.$

CAN controller interface

PCA82C250

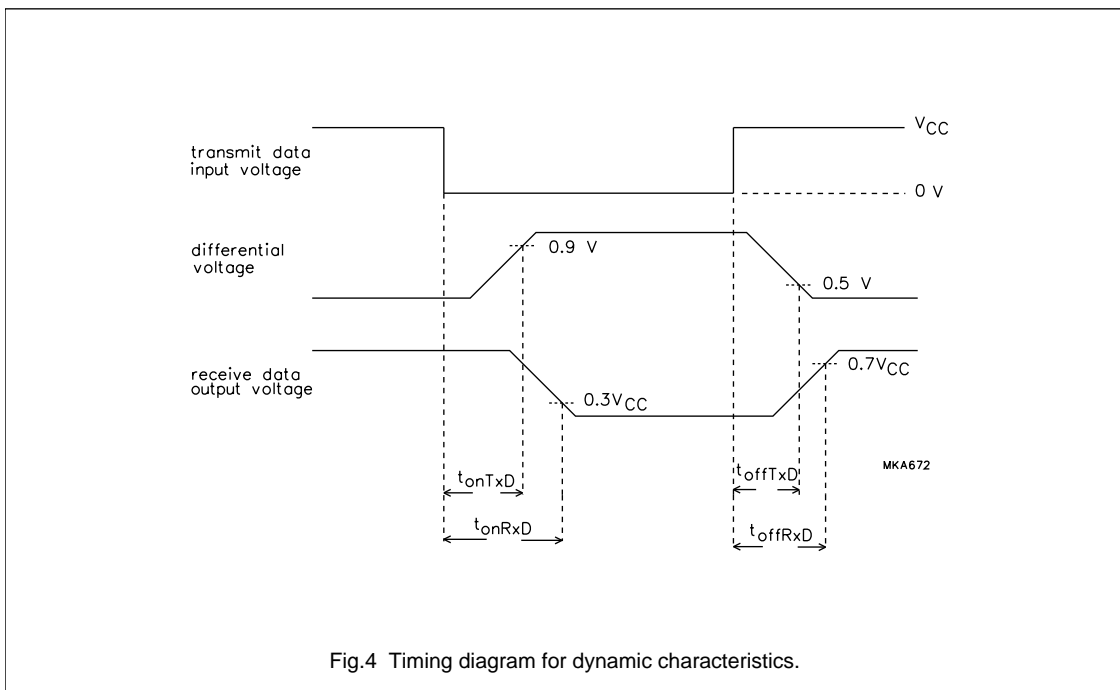
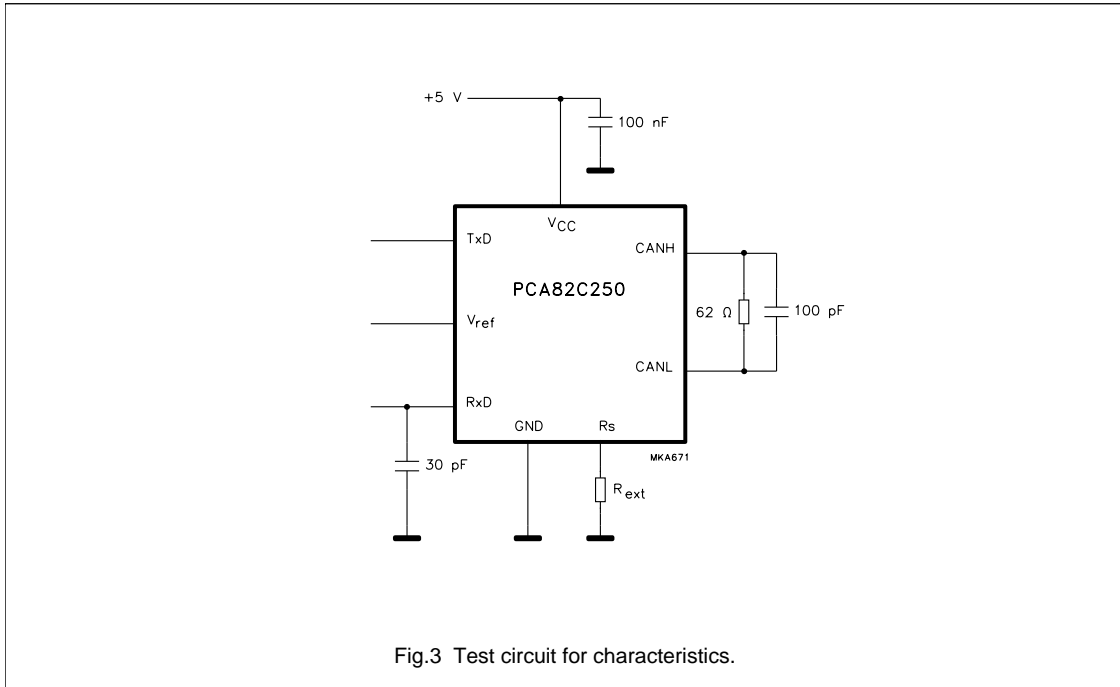

CAN controller interface

PCA82C250

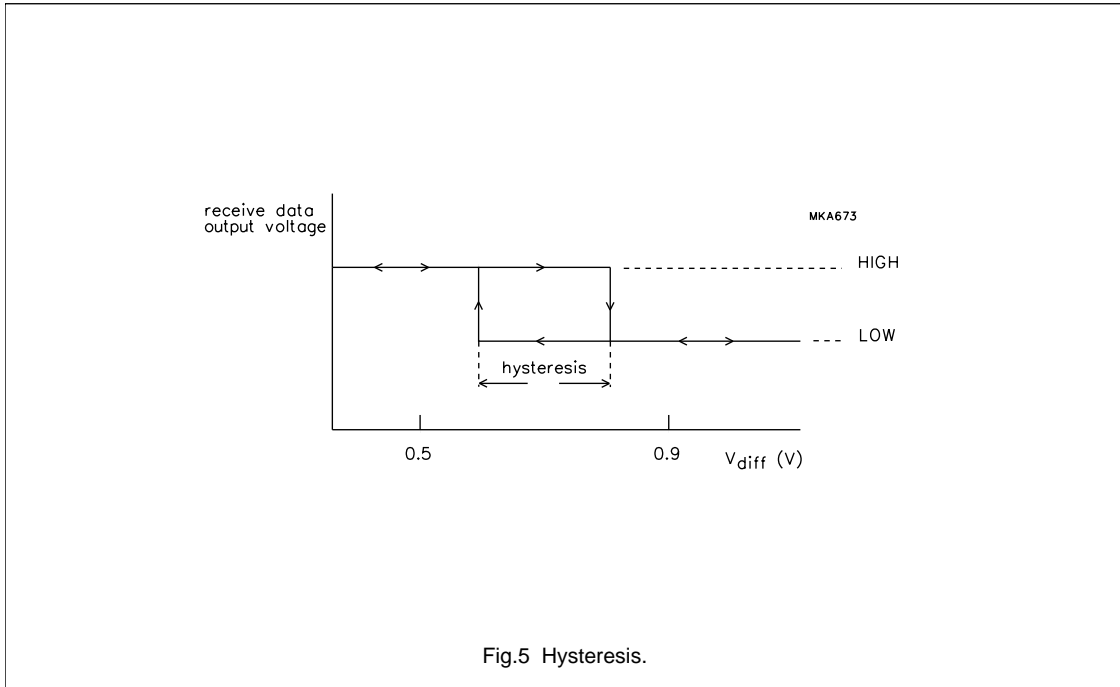
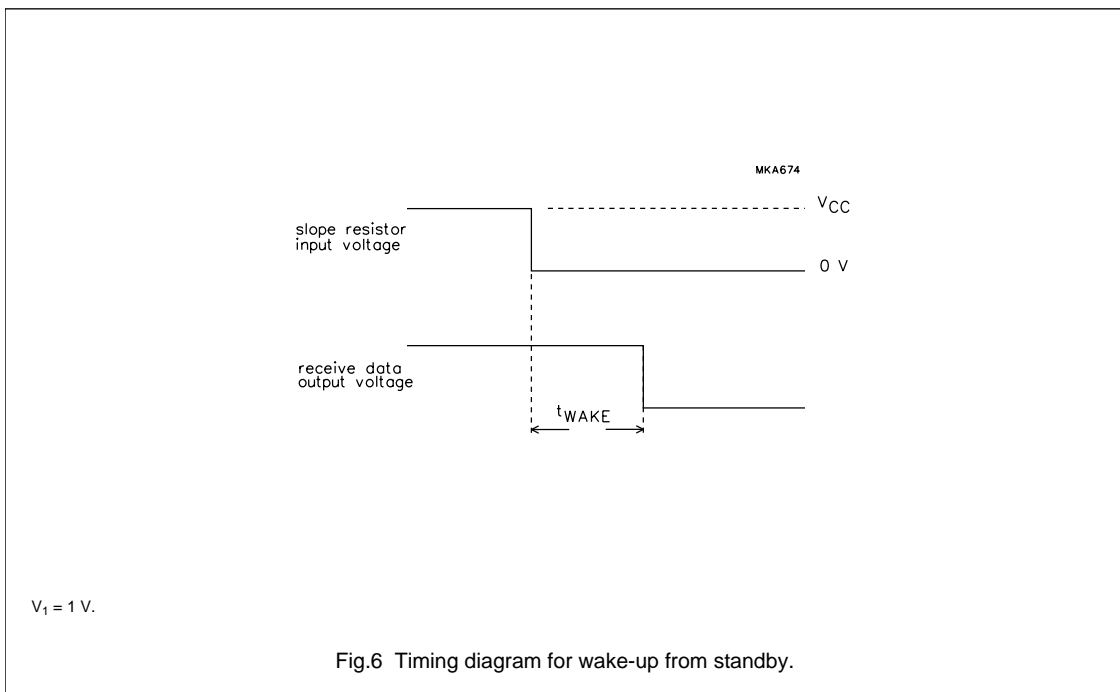

Fig.5 Hysteresis.



$V_1 = 1$ V.

Fig.6 Timing diagram for wake-up from standby.

CAN controller interface

PCA82C250

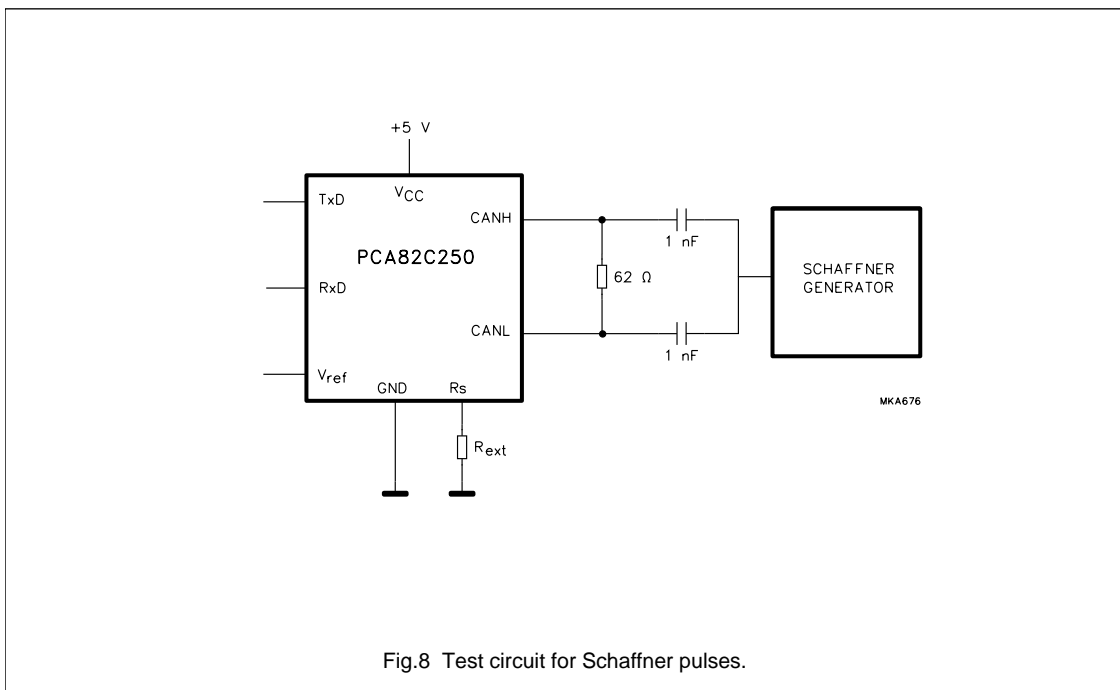
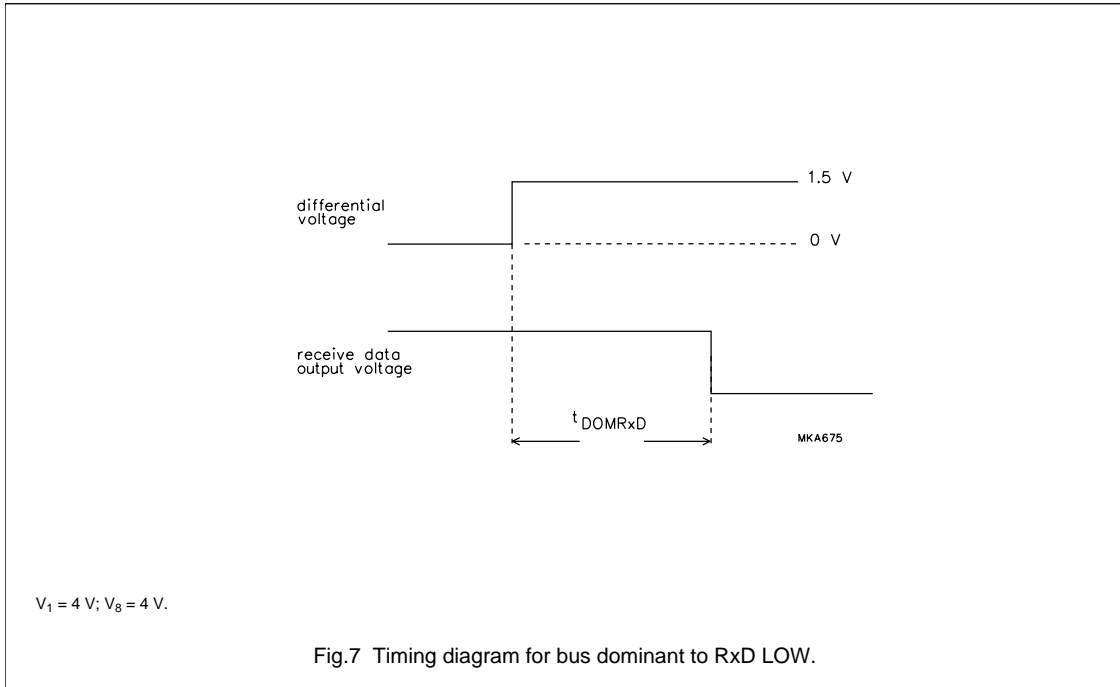

CAN controller interface

PCA82C250

APPLICATION INFORMATION

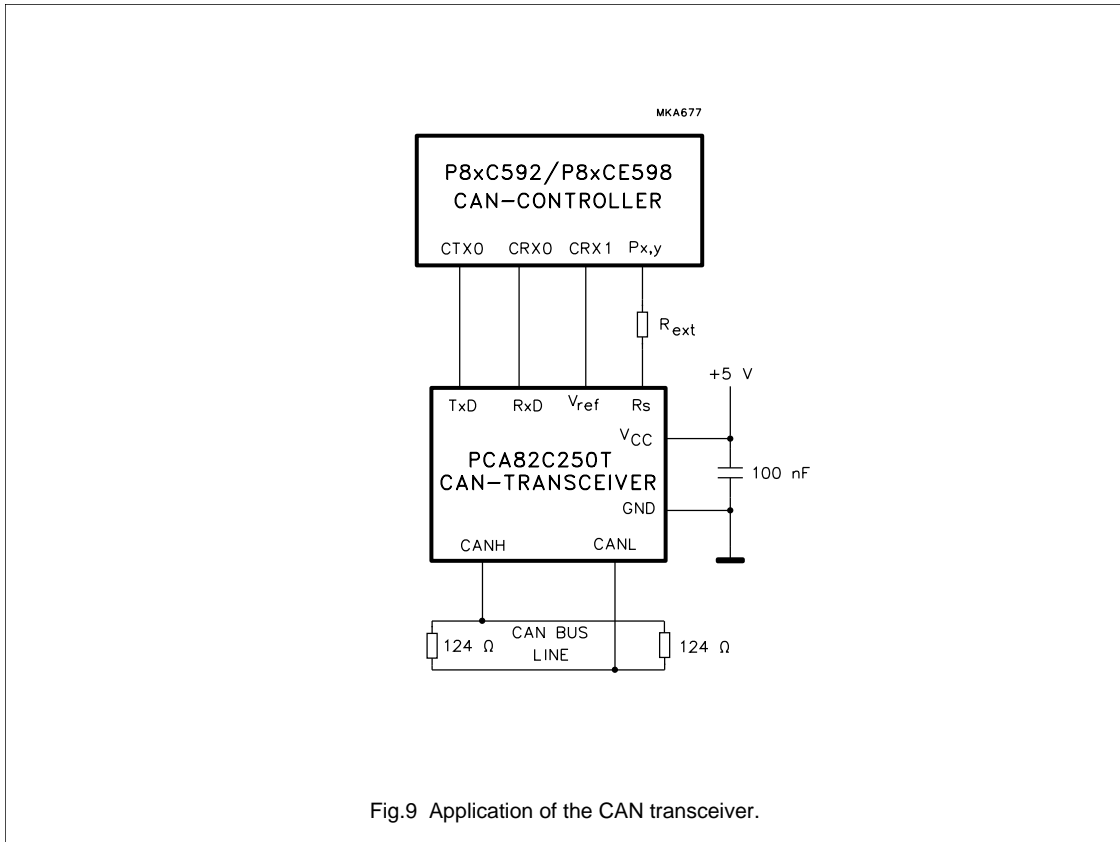

CAN controller interface

PCA82C250

INTERNAL PIN CONFIGURATION

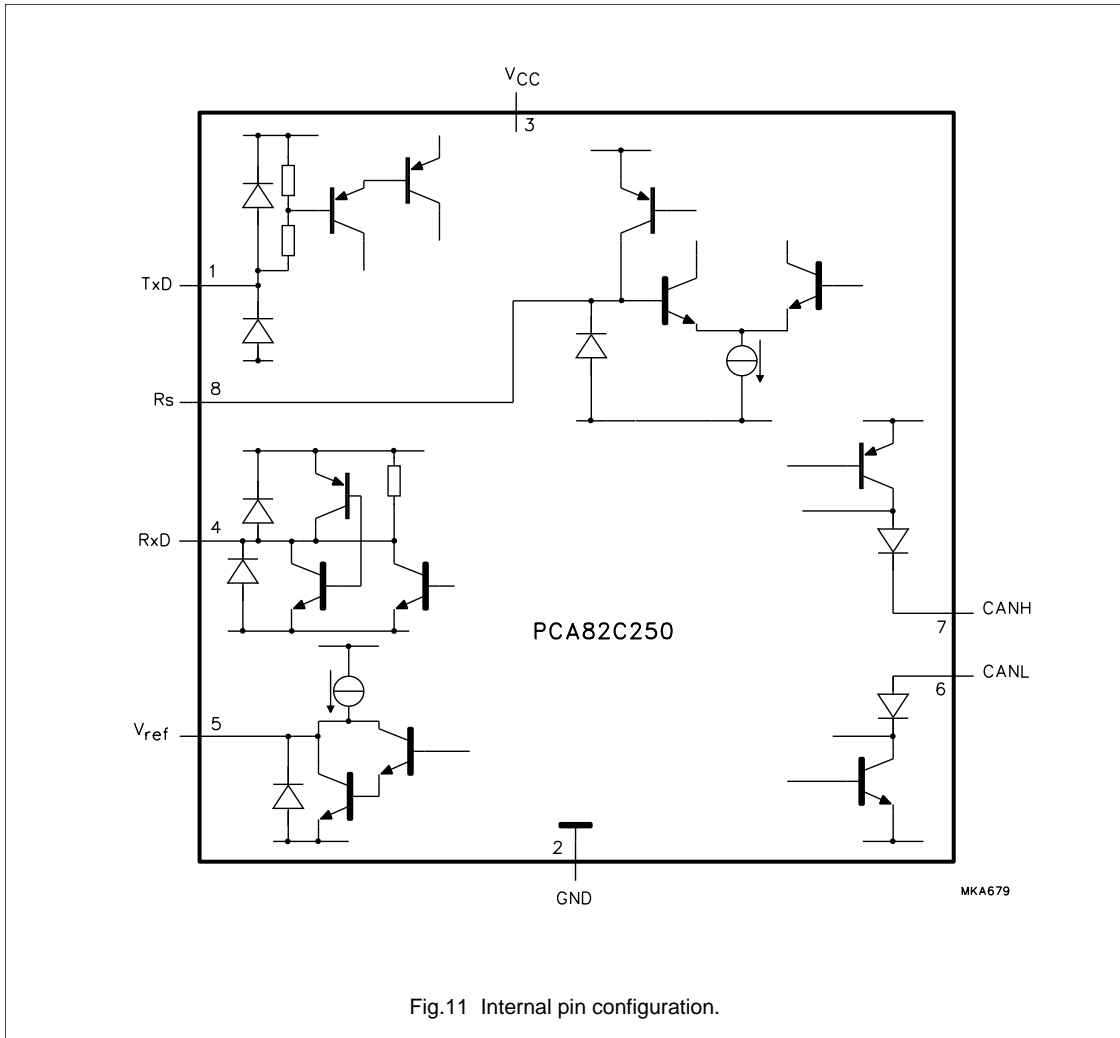
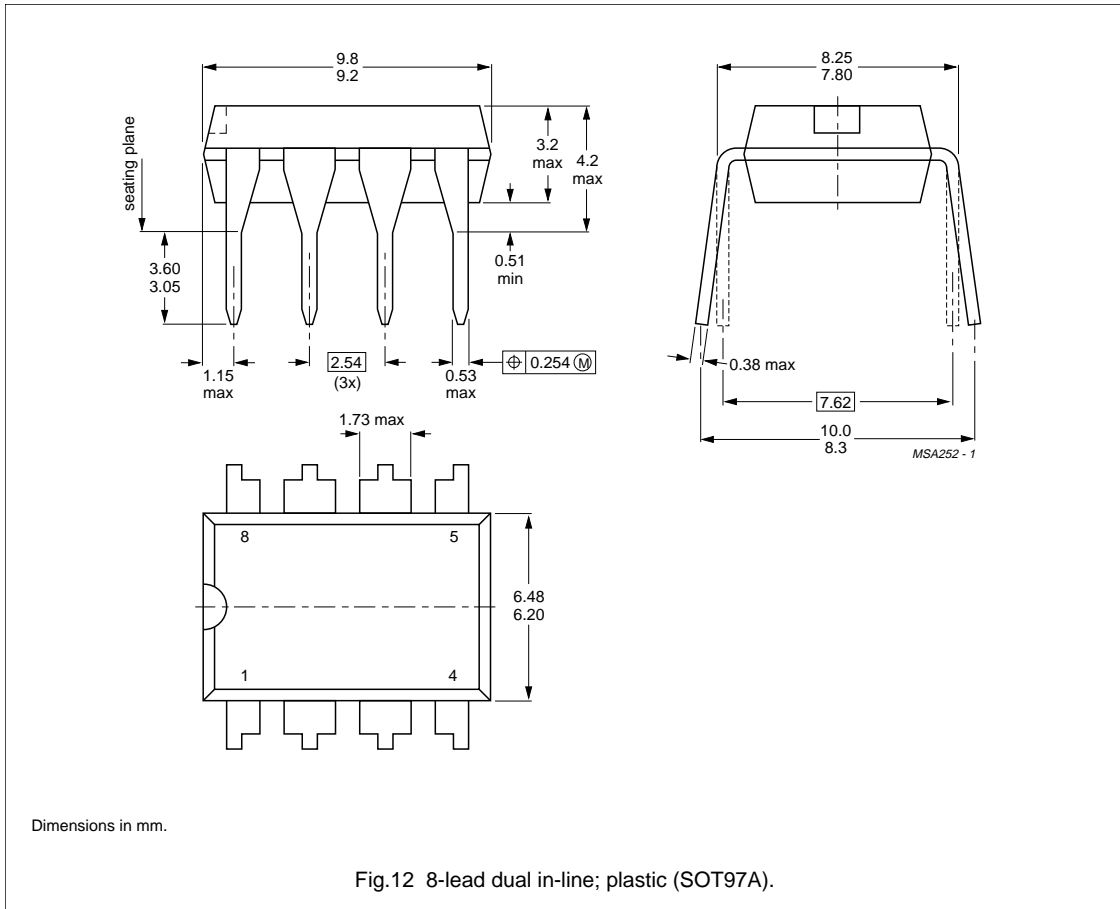

Fig.11 Internal pin configuration.

CAN controller interface

PCA82C250

PACKAGE OUTLINES



CAN controller interface

PCA82C250

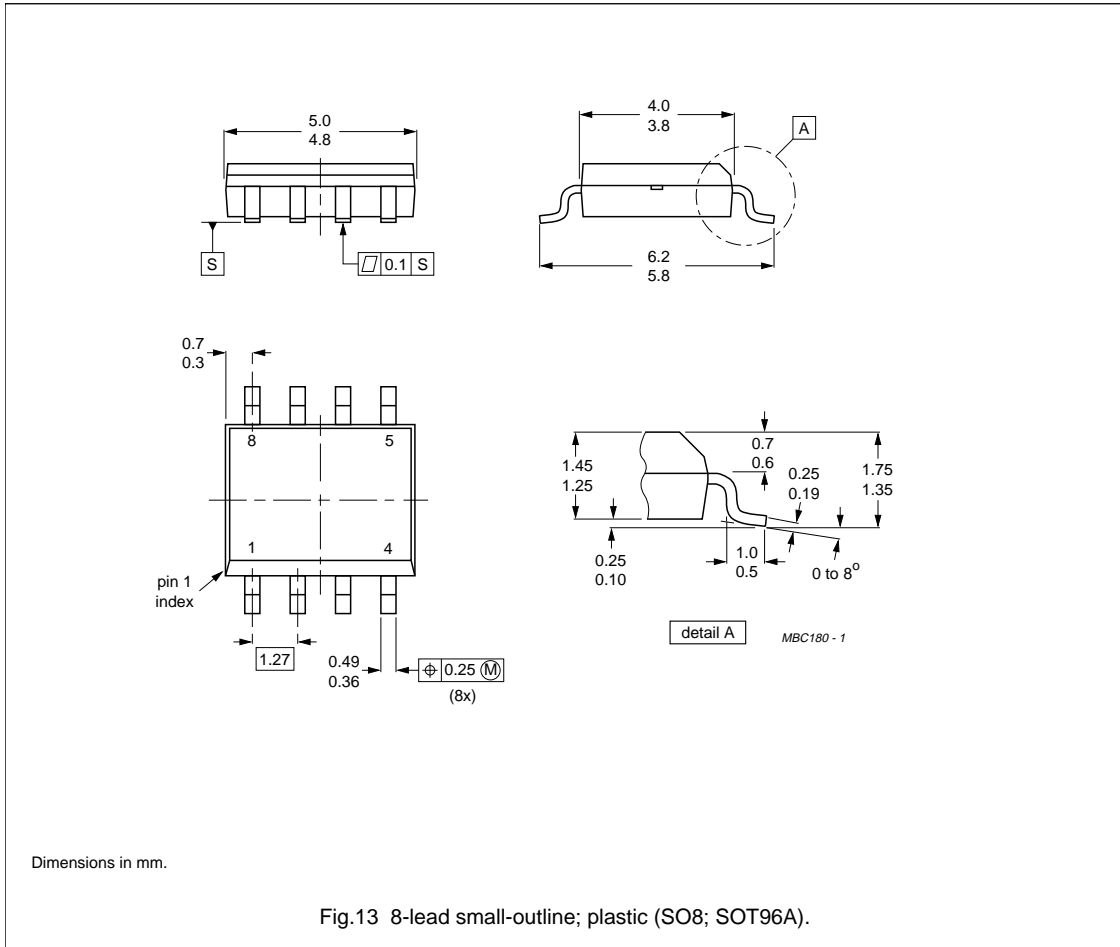

CAN controller interface**PCA82C250**

SOLDERING**Plastic dual in-line packages**

BY DIP OR WAVE

The maximum permissible temperature of the solder is 260 °C; this temperature must not be in contact with the joint for more than 5 s. The total contact time of successive solder waves must not exceed 5 s.

The device may be mounted up to the seating plane, but the temperature of the plastic body must not exceed the specified storage maximum. If the printed-circuit board has been pre-heated, forced cooling may be necessary immediately after soldering to keep the temperature within the permissible limit.

REPAIRING SOLDERED JOINTS

Apply a low voltage soldering iron below the seating plane (or not more than 2 mm above it). If its temperature is below 300 °C, it must not be in contact for more than 10 s; if between 300 and 400 °C, for not more than 5 s.

Plastic small-outline packages

BY WAVE

During placement and before soldering, the component must be fixed with a droplet of adhesive. After curing the adhesive, the component can be soldered. The adhesive can be applied by screen printing, pin transfer or syringe dispensing.

Maximum permissible solder temperature is 260 °C, and maximum duration of package immersion in solder bath is 10 s, if allowed to cool to less than 150 °C within 6 s. Typical dwell time is 4 s at 250 °C.

A modified wave soldering technique is recommended using two solder waves (dual-wave), in which a turbulent wave with high upward pressure is followed by a smooth laminar wave. Using a mildly-activated flux eliminates the need for removal of corrosive residues in most applications.

BY SOLDER PASTE REFLOW

Reflow soldering requires the solder paste (a suspension of fine solder particles, flux and binding agent) to be applied to the substrate by screen printing, stencilling or pressure-syringe dispensing before device placement.

Several techniques exist for reflowing; for example, thermal conduction by heated belt, infrared, and vapour-phase reflow. Dwell times vary between 50 and 300 s according to method. Typical reflow temperatures range from 215 to 250 °C.

Preheating is necessary to dry the paste and evaporate the binding agent. Preheating duration: 45 min at 45 °C.

REPAIRING SOLDERED JOINTS (BY HAND-HELD SOLDERING IRON OR PULSE-HEATED SOLDER TOOL)

Fix the component by first soldering two, diagonally opposite, end pins. Apply the heating tool to the flat part of the pin only. Contact time must be limited to 10 s at up to 300 °C. When using proper tools, all other pins can be soldered in one operation within 2 to 5 s at between 270 and 320 °C. (Pulse-heated soldering is not recommended for SO packages.)

For pulse-heated solder tool (resistance) soldering of VSO packages, solder is applied to the substrate by dipping or by an extra thick tin/lead plating before package placement.

CAN controller interface

PCA82C250

DEFINITIONS

Data sheet status	
Objective specification	This data sheet contains target or goal specifications for product development.
Preliminary specification	This data sheet contains preliminary data; supplementary data may be published later.
Product specification	This data sheet contains final product specifications.
Limiting values	
Limiting values given are in accordance with the Absolute Maximum Rating System (IEC 134). Stress above one or more of the limiting values may cause permanent damage to the device. These are stress ratings only and operation of the device at these or at any other conditions above those given in the Characteristics sections of the specification is not implied. Exposure to limiting values for extended periods may affect device reliability.	
Application information	
Where application information is given, it is advisory and does not form part of the specification.	

LIFE SUPPORT APPLICATIONS

These products are not designed for use in life support appliances, devices, or systems where malfunction of these products can reasonably be expected to result in personal injury. Philips customers using or selling these products for use in such applications do so at their own risk and agree to fully indemnify Philips for any damages resulting from such improper use or sale.

CAN controller interface**PCA82C250****FEATURES**

- Fully compatible with the "ISO/DIS 11898" standard
- High speed (up to 1 Mbaud)
- Bus lines protected against transients in an automotive environment
- Slope control to reduce radio frequency interference (RFI)
- Differential receiver with wide common-mode range for high immunity against electron magnetic interference (EMI)
- Thermally protected
- Short-circuit proof to battery and ground
- Low current standby mode
- An unpowered node does not disturb the bus lines
- At least 110 nodes can be connected.

APPLICATIONS

- High-speed applications (up to 1 Mbaud) in cars.

GENERAL DESCRIPTION

The PCA82C250 is the interface between the CAN protocol controller and the physical bus. The device provides differential transmit capability to the bus and differential receive capability to the CAN controller.

QUICK REFERENCE DATA

SYMBOL	PARAMETER	CONDITIONS	MIN.	MAX.	UNIT
V _{CC}	supply voltage		4.5	5.5	V
I _{CC}	supply current		–	170	μA
1/t _{bit}	maximum transmission speed	non-return-to-zero	1	–	Mbaud
V _{CAN}	CANH, CANL input/output voltage		–8	+18	V
ΔV	differential bus voltage		1.5	3.0	V
t _{pd}	propagation delay	high-speed mode	–	50	ns
T _{amb}	operating ambient temperature		–40	+125	°C

ORDERING INFORMATION

EXTENDED TYPE NUMBER	PACKAGE			
	PINS	PIN POSITION	MATERIAL	CODE
PCA82C250	8	DIL8	plastic	SOT97A
PCA82C250T	8	SO8	plastic	SOT96A

CAN controller interface

PCA82C250

BLOCK DIAGRAM

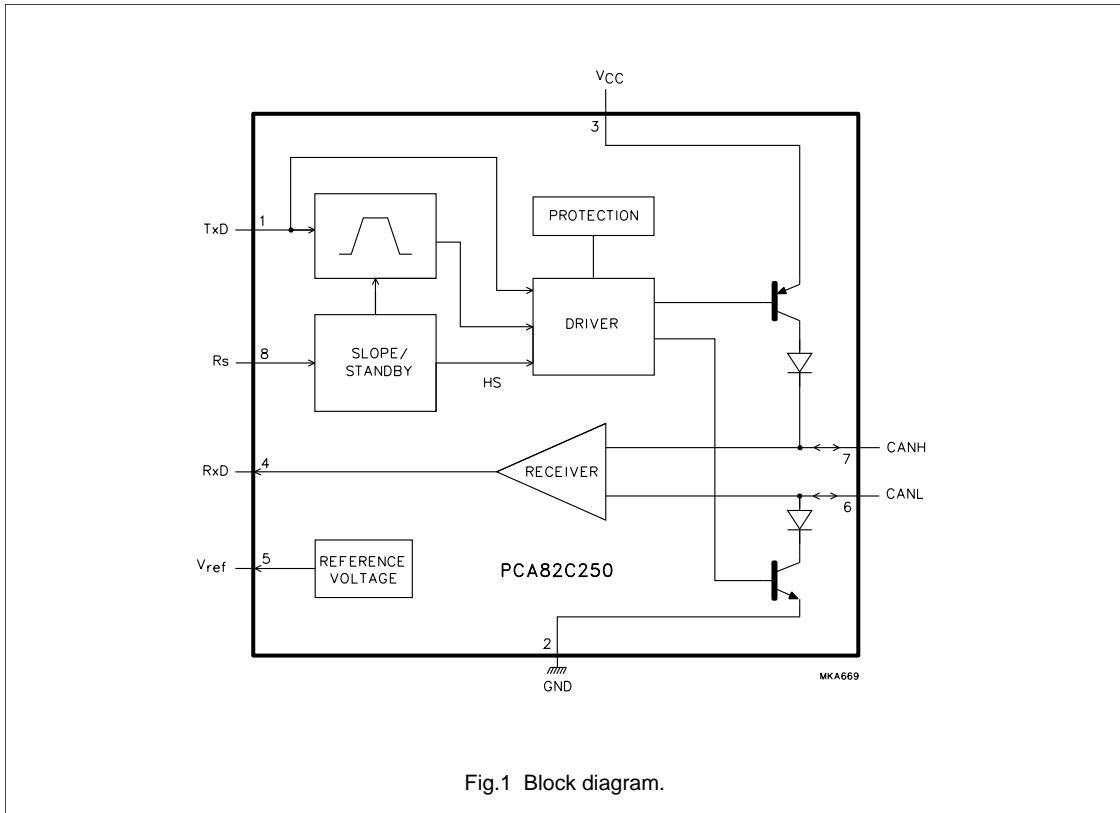

Fig.1 Block diagram.

PINNING

SYMBOL	PIN	DESCRIPTION
TxD	1	transmit data input
GND	2	ground
V _{CC}	3	supply voltage
RxD	4	receive data output
V _{ref}	5	reference voltage output
CANL	6	LOW level CAN voltage input/output
CANH	7	HIGH level CAN voltage input/output
Rs	8	slope resistor input

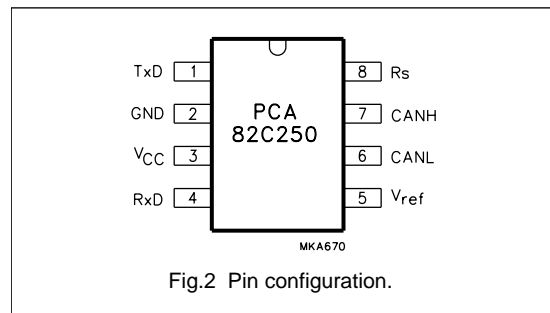

Fig.2 Pin configuration.

CAN controller interface

PCA82C250

FUNCTIONAL DESCRIPTION

The PCA82C250 is the interface between the CAN protocol controller and the physical bus. It is primarily intended for high-speed applications (up to 1 Mbaud) in cars. The device provides differential transmit capability to the bus and differential receive capability to the CAN controller. It is fully compatible with the "ISO/DIS 11898" standard.

A current limiting circuit protects the transmitter output stage against short-circuit to positive and negative battery voltage. Although the power dissipation is increased during this fault condition, this feature will prevent destruction of the transmitter output stage.

If the junction temperature exceeds a value of approximately 160 °C, the limiting current of both transmitter outputs is decreased. Because the transmitter is responsible for the major part of the power dissipation, this will result in a reduced power dissipation and hence a lower chip temperature. All other parts of the IC will remain in operation. The thermal protection is particularly needed when a bus line is short-circuited.

The CANH and CANL lines are also protected against electrical transients which may occur in an automotive environment. Pin 8 (Rs) allows three different modes of operation to be selected: high-speed, slope control or standby.

For high-speed operation, the transmitter output transistors are simply switched on and off as fast as possible. In this mode, no measures are taken to limit the rise and fall slope. Use of a shielded cable is recommended to avoid RFI problems. The high-speed mode is selected by connecting pin 8 to ground.

For lower speeds or shorter bus length, an unshielded twisted pair or a parallel pair of wires can be used for the bus. To reduce RFI, the rise and fall slope should be limited. The rise and fall slope can be programmed with a resistor connected from pin 8 to ground. The slope is proportional to the current output at pin 8.

If a HIGH level is applied to pin 8, the circuit enters a low current standby mode. In this mode, the transmitter is switched off and the receiver is switched to a low current. If dominant bits are detected (differential bus voltage >0.9 V), RxD will be switched to a LOW level. The microcontroller should react to this condition by switching the transceiver back to normal operation (via pin 8). Because the receiver is slow in standby mode, the first message will be lost.

Table 1 Truth table of CAN transceiver.

SUPPLY	TxD	CANH	CANL	BUS STATE	RxD
4.5 to 5.5 V	0	HIGH	LOW	dominant	0
4.5 to 5.5 V	1 (or floating)	floating	floating	recessive	1
<2 V (not powered)	X	floating	floating	recessive	X
$2 V < V_{CC} < 4.5 V$	$>0.75V_{CC}$	floating	floating	recessive	X
$2 V < V_{CC} < 4.5 V$	X	floating if $V_{Rs} > 0.75V_{CC}$	floating if $V_{Rs} > 0.75V_{CC}$	recessive	X

Table 2 Rs (pin 8) summary.

CONDITION FORCED AT Rs	MODE	RESULTING VOLTAGE OR CURRENT AT Rs
$V_{Rs} > 0.75V_{CC}$	standby	$ I_{Rs} < 10 \mu A$
$10 \mu A < I_{Rs} < 200 \mu A$	slope control	$0.4V_{CC} < V_{Rs} < 0.6V_{CC}$
$V_{Rs} < 0.3V_{CC}$	high-speed	$I_{Rs} < -500 \mu A$

CAN controller interface

PCA82C250

LIMITING VALUES

In accordance with the Absolute Maximum Rating System (IEC 134). All voltages are referenced to pin 2; positive input current.

SYMBOL	PARAMETER	CONDITIONS	MIN.	MAX.	UNIT
V_{CC}	supply voltage		-0.3	+9.0	V
V_n	DC voltage at pins 1, 4, 5 and 8		-0.3	$V_{CC} + 0.3$	V
$V_{6,7}$	DC voltage at pins 6 and 7	$0\text{ V} < V_{CC} < 5.5\text{ V}$; no time limit	-8.0	+18.0	V
V_{trt}	transient voltage at pins 6 and 7	see Fig.8	-150	+100	V
T_{stg}	storage temperature		-55	+150	°C
T_{amb}	operating ambient temperature		-40	+125	°C
T_{vj}	virtual junction temperature	note 1	-40	+150	°C

Note

1. In accordance with "IEC 747-1".

An alternative definition of virtual junction temperature T_{vj} is: $T_{vj} = T_{amb} + P_d \times R_{th\ vj-amb}$,
where $R_{th\ vj-amb}$ is a fixed value to be used for the calculation of T_{vj} .

The rating for T_{vj} limits the allowable combinations of power dissipation (P_d) and ambient temperature (T_{amb}).

HANDLING

Classification A: human body model; C = 100 pF; R = 1500 Ω ; V = ± 2000 V.

Classification B: machine model; C = 200 pF; R = 0 Ω ; V = ± 200 V.

QUALITY SPECIFICATION

Quality specification "SNW-FQ-611 part E" is applicable and can be found in the "Quality reference pocket-book" (ordering number 9398 510 34011).

THERMAL RESISTANCE

SYMBOL	PARAMETER	THERMAL RESISTANCE
$R_{th\ j-a}$	from junction to ambient in free air	
	PCA82C250	100 K/W
	PCA82C250T	160 K/W

CAN controller interface

PCA82C250

CHARACTERISTICS

$V_{CC} = 4.5$ to 5.5 V; $T_{amb} = -40$ to $+25$ °C; $R_L = 60$ Ω; $I_B > -10$ μA; unless otherwise specified.

All voltages referenced to ground (pin 2); positive input current; all parameters are guaranteed over the ambient temperature range by design, but only 100% tested at $+25$ °C.

SYMBOL	PARAMETER	CONDITIONS	MIN.	TYP.	MAX.	UNIT
Supply						
I_3	supply current	dominant; $V_1 = 1$ V	–	–	70	mA
		recessive; $V_1 = 4$ V; $R_8 = 47$ kΩ	–	–	14	mA
		recessive; $V_1 = 4$ V; $V_8 = 1$ V	–	–	18	mA
		standby; $T_{amb} < 90$ °C; note 1	–	100	170	μA
DC bus transmitter						
V_{IH}	HIGH level input voltage	output recessive	$0.7V_{CC}$	–	$V_{CC} + 0.3$	V
V_{IL}	LOW level input voltage	output dominant	–0.3	–	$0.3V_{CC}$	V
I_{IH}	HIGH level input current	$V_1 = 4$ V	–200	–	+30	μA
I_{IL}	LOW level input voltage	$V_1 = 1$ V	100	–	600	μA
$V_{6,7}$	recessive bus voltage	$V_1 = 4$ V; no load	2.0	–	3.0	V
I_{LO}	off-state output leakage current	-2 V < (V_6, V_7) < 7 V	–2	–	+1	mA
		-2 V < (V_6, V_7) < 18 V	–5	–	+12	mA
V_7	CANH output voltage	$V_1 = 1$ V	2.75	–	4.5	V
V_6	CANL output voltage	$V_1 = 1$ V	0.5	–	2.25	V
$\Delta V_{6,7}$	difference between output voltage at pins 6 and 7	$V_1 = 1$ V	1.5	–	3.0	V
		$V_1 = 1$ V; $R_L = 45$ Ω; $V_{CC} \geq 4.9$ V	1.5	–	–	V
		$V_1 = 4$ V; no load	–500	–	+50	mA
I_{sc7}	short-circuit CANH current	$V_7 = -5$ V; $V_{CC} \leq 5$ V	–	–	105	mA
		$V_7 = -5$ V; $V_{CC} = 5.5$ V	–	–	120	mA
I_{sc6}	short-circuit CANL current	$V_6 = +18$ V	–	–	160	mA
DC bus receiver: $V_1 = 4$ V; pins 6 and 7 externally driven; -2 V < (V_6, V_7) < 7 V; unless otherwise specified						
$V_{diff(r)}$	differential input voltage (recessive)		–1.0	–	0.5	V
		-7 V < (V_6, V_7) < 12 V; not standby mode	–1.0	–	0.4	V
$V_{diff(d)}$	differential input voltage (dominant)		0.9	–	5.0	V
		-7 V < (V_6, V_7) < 12 V; not standby mode	1.0	–	5.0	V
$V_{diff(hys)}$	differential input hysteresis	see Fig.5	–	150	–	mV
V_{OH}	HIGH level output voltage (pin 4)	$I_4 = -100$ μA	$0.8V_{CC}$	–	V_{CC}	V
V_{OL}	LOW level output voltage (pin 4)	$I_4 = 1$ mA	0	–	$0.2V_{CC}$	V
		$I_4 = 10$ mA	0	–	1.5	V
R_i	CANH, CANL input resistance		5	–	25	kΩ

CAN controller interface

PCA82C250

SYMBOL	PARAMETER	CONDITIONS	MIN.	TYP.	MAX.	UNIT
R_{diff}	differential input resistance		20	–	100	k Ω
C_i	CANH, CANL input capacitance		–	–	20	pF
C_{diff}	differential input capacitance		–	–	10	pF
Reference output						
V_{ref}	reference output voltage	$V_8 = 1\text{ V};$ $-50\ \mu\text{A} < I_5 < 50\ \mu\text{A}$	$0.45V_{CC}$	–	$0.55V_{CC}$	V
		$V_8 = 4\text{ V};$ $-50\ \mu\text{A} < I_5 < 50\ \mu\text{A}$	$0.4V_{CC}$	–	$0.6V_{CC}$	V
Timing (see Figs 4, 6 and 7)						
t_{bit}	minimum bit time	$V_8 = 1\text{ V}$	–	–	1	μs
t_{onTxD}	delay TxD to bus active	$V_8 = 1\text{ V}$	–	–	50	ns
t_{offTxD}	delay TxD to bus inactive	$V_8 = 1\text{ V}$	–	40	80	ns
t_{onRxD}	delay TxD to receiver active	$V_8 = 1\text{ V}$	–	55	120	ns
t_{offRxD}	delay TxD to receiver inactive	$V_8 = 1\text{ V}; V_{CC} < 5.1\text{ V};$ $T_{amb} < +85\text{ }^\circ\text{C}$	–	82	150	ns
		$V_8 = 1\text{ V}; V_{CC} < 5.1\text{ V};$ $T_{amb} < +125\text{ }^\circ\text{C}$	–	82	170	ns
		$V_8 = 1\text{ V}; V_{CC} < 5.5\text{ V};$ $T_{amb} < +85\text{ }^\circ\text{C}$	–	90	170	ns
		$V_8 = 1\text{ V}; V_{CC} < 5.5\text{ V};$ $T_{amb} < +125\text{ }^\circ\text{C}$	–	90	190	ns
t_{onRxD}	delay TxD to receiver active	$R_8 = 47\text{ k}\Omega$	–	390	520	ns
		$R_8 = 24\text{ k}\Omega$	–	260	320	ns
t_{offRxD}	delay TxD to receiver inactive	$R_8 = 47\text{ k}\Omega$	–	260	450	ns
		$R_8 = 24\text{ k}\Omega$	–	210	320	ns
$ SR $	differential output voltage slew rate	$R_8 = 47\text{ k}\Omega$	–	14	–	V/ μs
t_{WAKE}	wake-up time from standby (via pin 8)		–	–	20	μs
t_{dRxDL}	bus dominant to RxD LOW	$V_8 = 4\text{ V};$ standby mode	–	–	3	μs
Standby/slope control (pin 8)						
V_8	input voltage for high-speed		–	–	$0.3V_{CC}$	V
I_8	input current for high-speed	$V_8 = 1\text{ V}$	–	–	–500	μA
V_{stb}	input voltage for standby mode		$0.75V_{CC}$	–	–	V
I_{slope}	slope control mode current		–10	–	–200	μA
V_{slope}	slope control mode voltage		$0.4V_{CC}$	–	$0.6V_{CC}$	V

Note

- $I_1 = I_4 = I_5 = 0\text{ mA}; 0 < V_7; V_6 < V_{CC}; V_8 = V_{CC}.$

CAN controller interface

PCA82C250

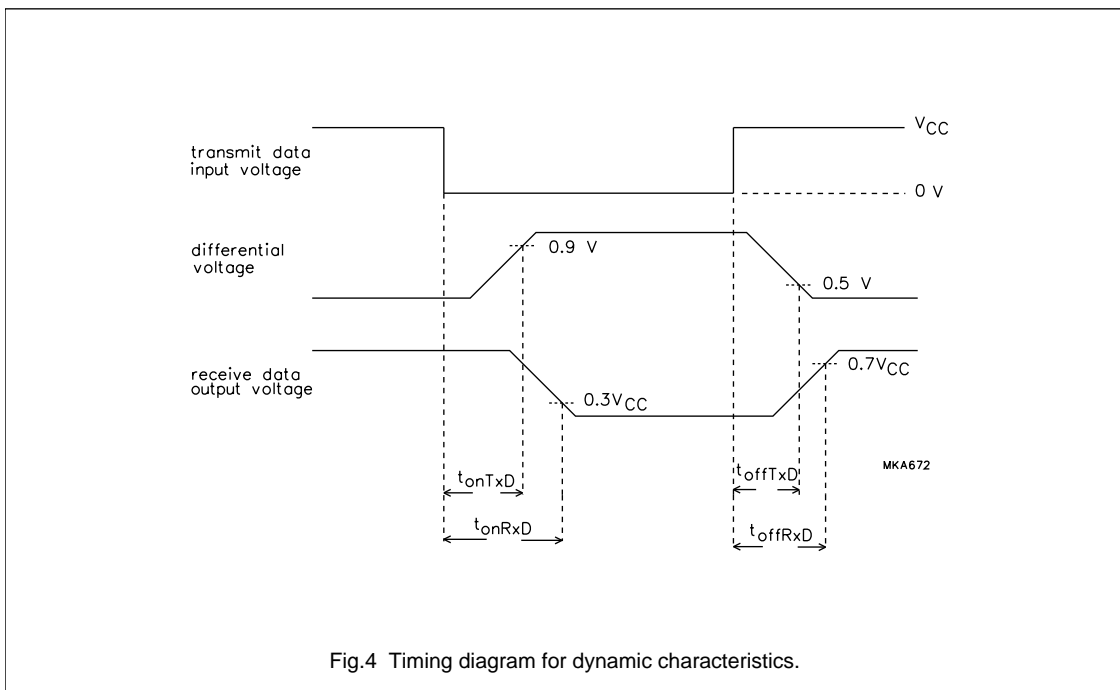
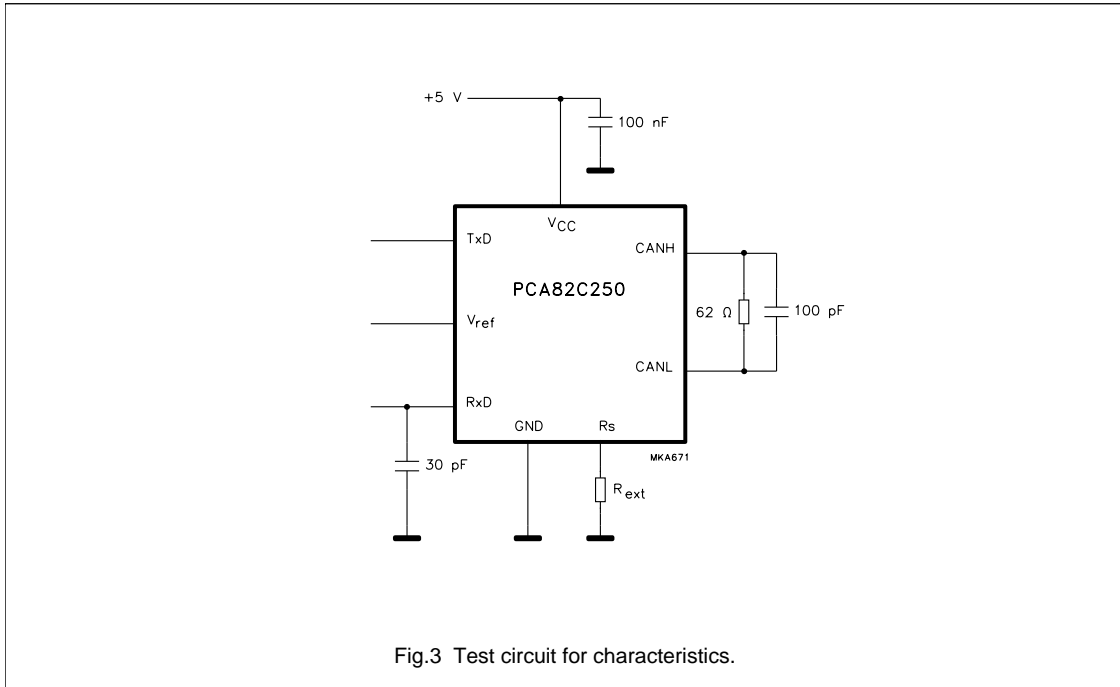

CAN controller interface

PCA82C250

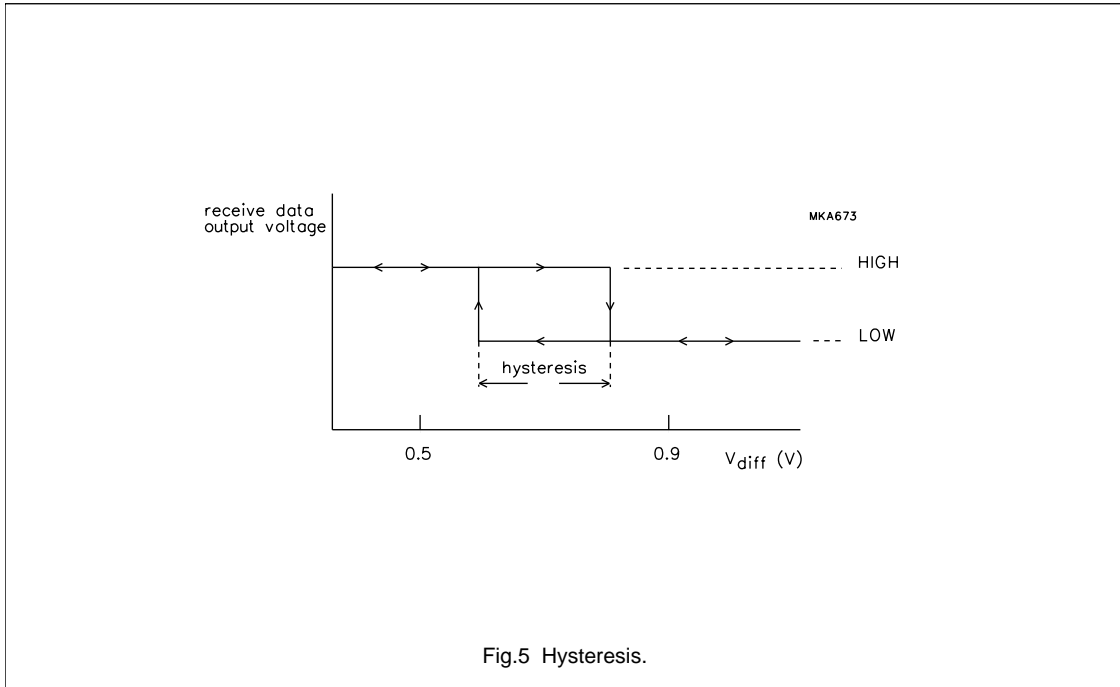

Fig.5 Hysteresis.

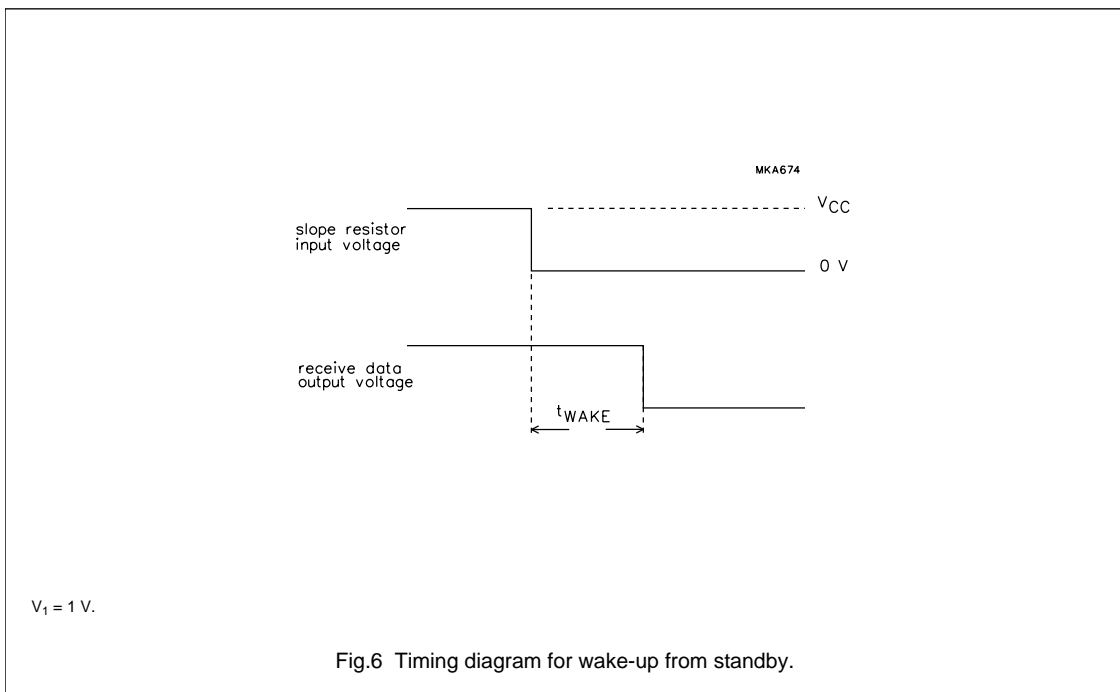
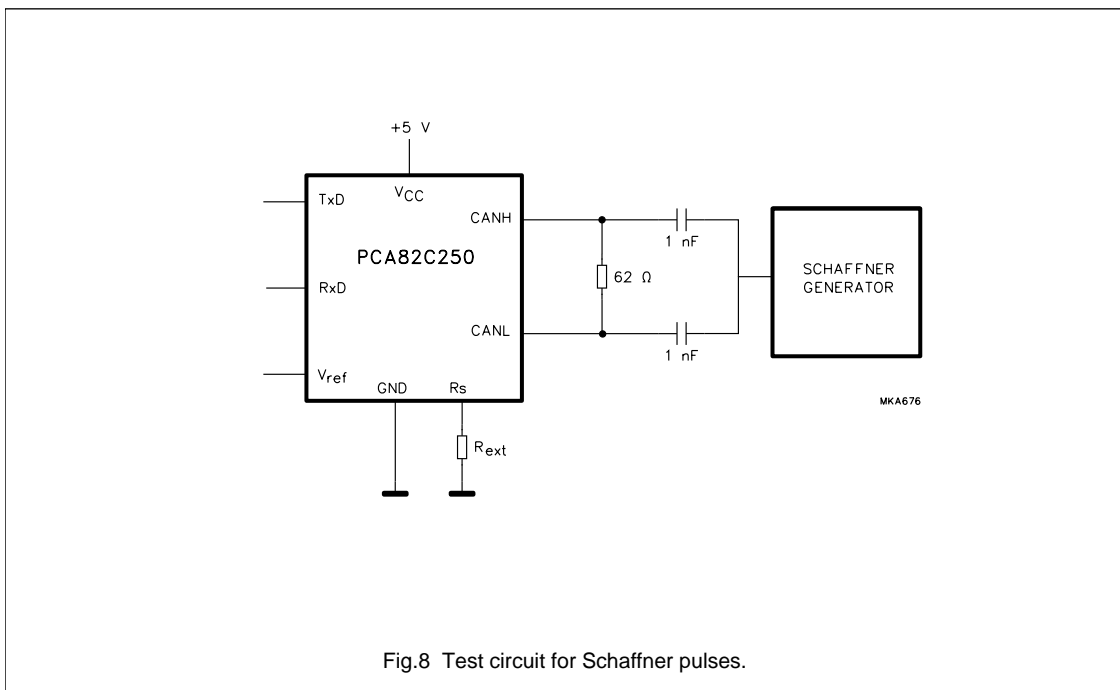
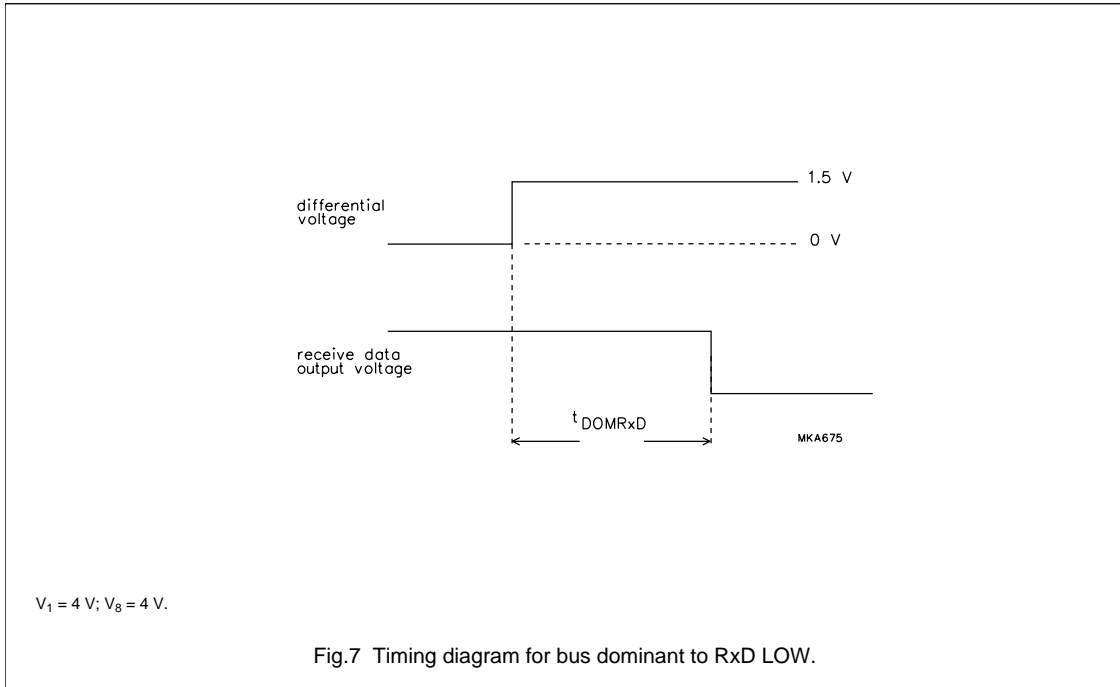

Fig.6 Timing diagram for wake-up from standby.

CAN controller interface

PCA82C250



CAN controller interface

PCA82C250

APPLICATION INFORMATION

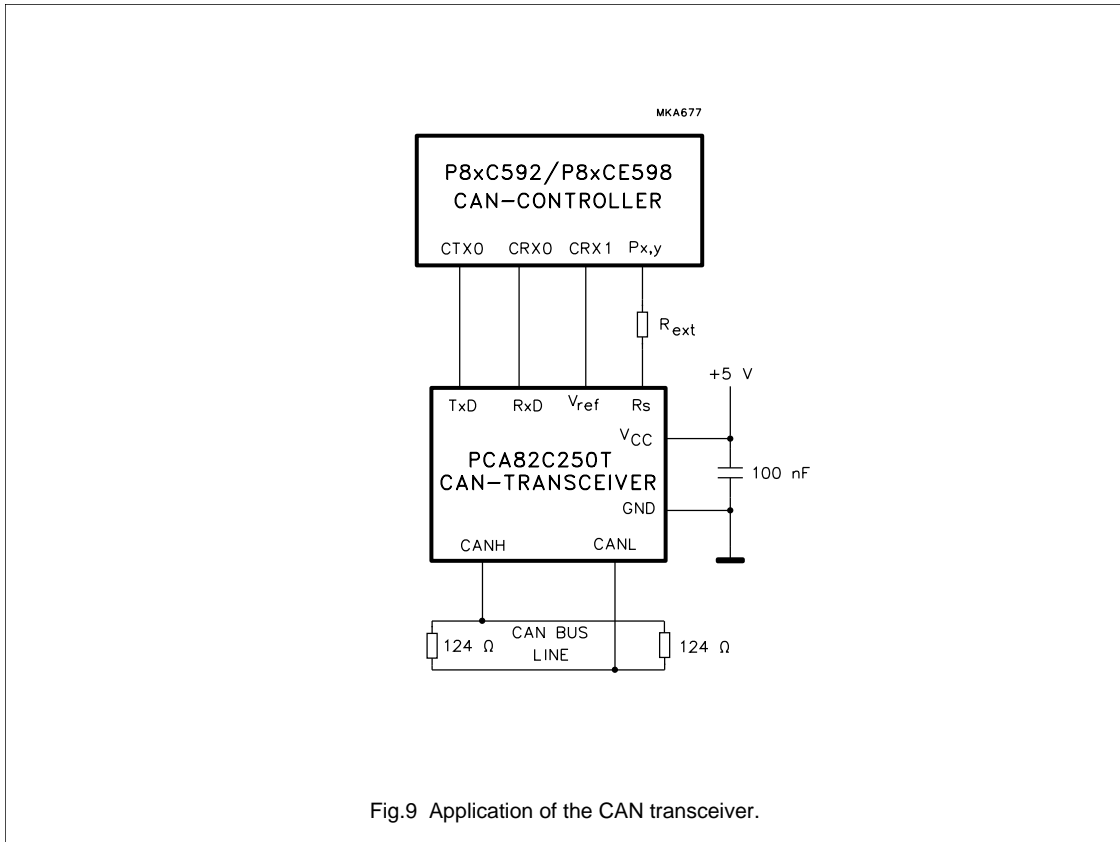

CAN controller interface

PCA82C250

INTERNAL PIN CONFIGURATION

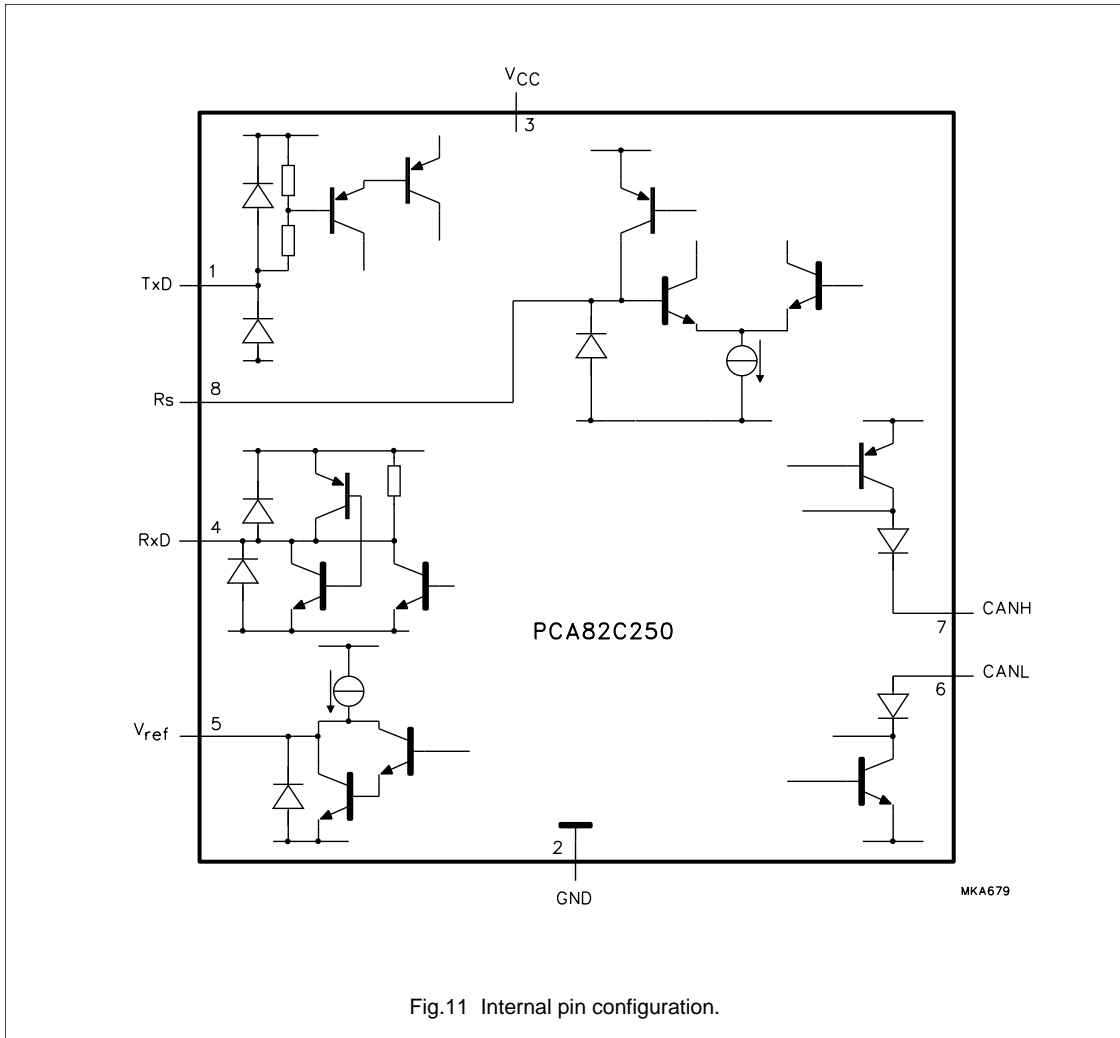
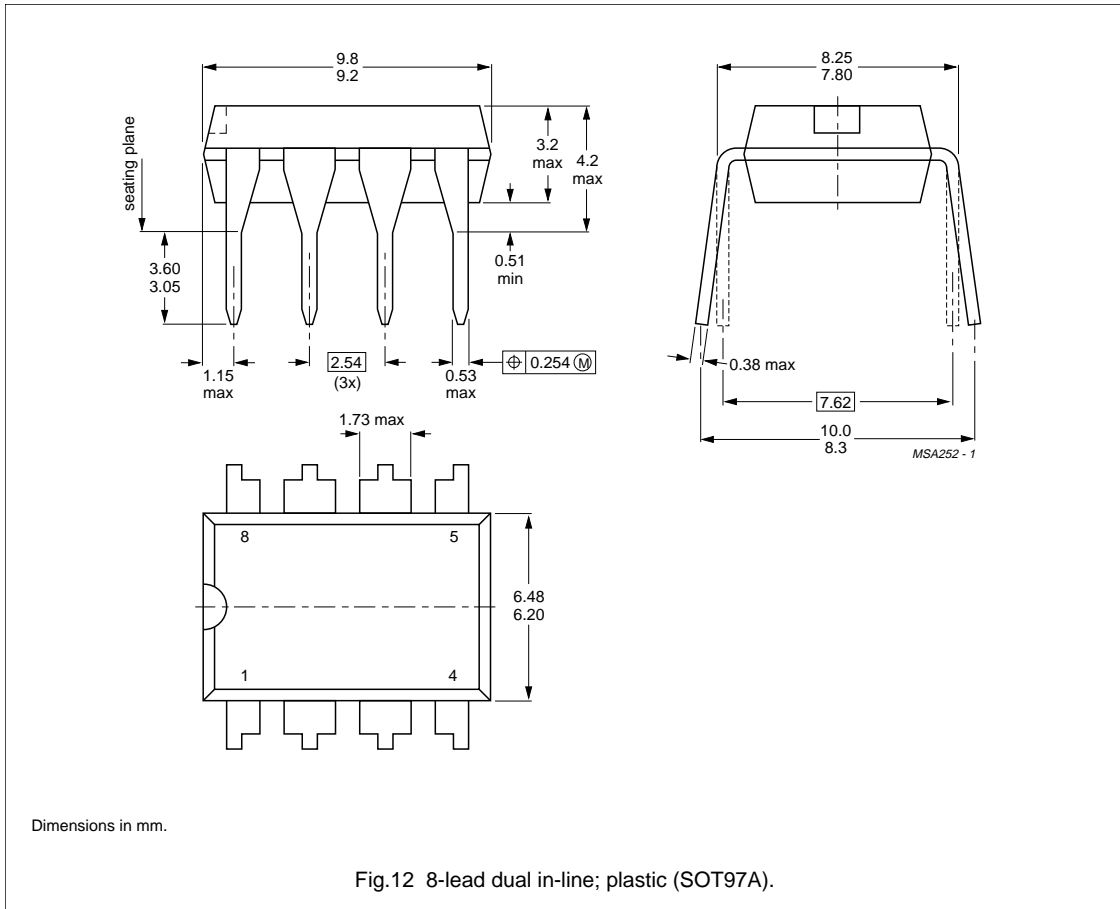

Fig.11 Internal pin configuration.

CAN controller interface

PCA82C250

PACKAGE OUTLINES



CAN controller interface

PCA82C250

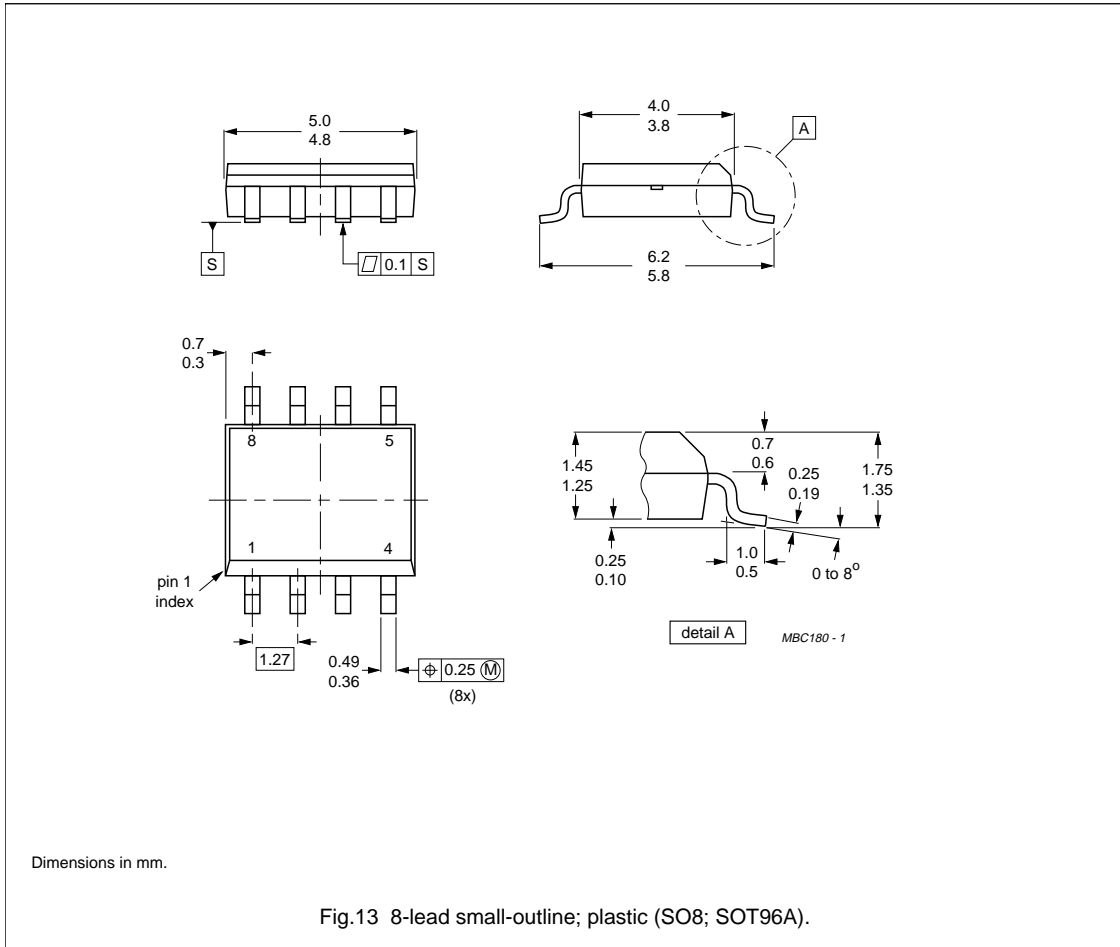

CAN controller interface**PCA82C250**

SOLDERING**Plastic dual in-line packages**

BY DIP OR WAVE

The maximum permissible temperature of the solder is 260 °C; this temperature must not be in contact with the joint for more than 5 s. The total contact time of successive solder waves must not exceed 5 s.

The device may be mounted up to the seating plane, but the temperature of the plastic body must not exceed the specified storage maximum. If the printed-circuit board has been pre-heated, forced cooling may be necessary immediately after soldering to keep the temperature within the permissible limit.

REPAIRING SOLDERED JOINTS

Apply a low voltage soldering iron below the seating plane (or not more than 2 mm above it). If its temperature is below 300 °C, it must not be in contact for more than 10 s; if between 300 and 400 °C, for not more than 5 s.

Plastic small-outline packages

BY WAVE

During placement and before soldering, the component must be fixed with a droplet of adhesive. After curing the adhesive, the component can be soldered. The adhesive can be applied by screen printing, pin transfer or syringe dispensing.

Maximum permissible solder temperature is 260 °C, and maximum duration of package immersion in solder bath is 10 s, if allowed to cool to less than 150 °C within 6 s. Typical dwell time is 4 s at 250 °C.

A modified wave soldering technique is recommended using two solder waves (dual-wave), in which a turbulent wave with high upward pressure is followed by a smooth laminar wave. Using a mildly-activated flux eliminates the need for removal of corrosive residues in most applications.

BY SOLDER PASTE REFLOW

Reflow soldering requires the solder paste (a suspension of fine solder particles, flux and binding agent) to be applied to the substrate by screen printing, stencilling or pressure-syringe dispensing before device placement.

Several techniques exist for reflowing; for example, thermal conduction by heated belt, infrared, and vapour-phase reflow. Dwell times vary between 50 and 300 s according to method. Typical reflow temperatures range from 215 to 250 °C.

Preheating is necessary to dry the paste and evaporate the binding agent. Preheating duration: 45 min at 45 °C.

REPAIRING SOLDERED JOINTS (BY HAND-HELD SOLDERING IRON OR PULSE-HEATED SOLDER TOOL)

Fix the component by first soldering two, diagonally opposite, end pins. Apply the heating tool to the flat part of the pin only. Contact time must be limited to 10 s at up to 300 °C. When using proper tools, all other pins can be soldered in one operation within 2 to 5 s at between 270 and 320 °C. (Pulse-heated soldering is not recommended for SO packages.)

For pulse-heated solder tool (resistance) soldering of VSO packages, solder is applied to the substrate by dipping or by an extra thick tin/lead plating before package placement.

CAN controller interface

PCA82C250

DEFINITIONS

Data sheet status	
Objective specification	This data sheet contains target or goal specifications for product development.
Preliminary specification	This data sheet contains preliminary data; supplementary data may be published later.
Product specification	This data sheet contains final product specifications.
Limiting values	
Limiting values given are in accordance with the Absolute Maximum Rating System (IEC 134). Stress above one or more of the limiting values may cause permanent damage to the device. These are stress ratings only and operation of the device at these or at any other conditions above those given in the Characteristics sections of the specification is not implied. Exposure to limiting values for extended periods may affect device reliability.	
Application information	
Where application information is given, it is advisory and does not form part of the specification.	

LIFE SUPPORT APPLICATIONS

These products are not designed for use in life support appliances, devices, or systems where malfunction of these products can reasonably be expected to result in personal injury. Philips customers using or selling these products for use in such applications do so at their own risk and agree to fully indemnify Philips for any damages resulting from such improper use or sale.